



## **Lecture 02**

# **Design of One-way Slab System (Part – I)**

By:

**Prof. Dr. Qaisar Ali**

Civil Engineering Department

UET Peshawar

[drqaisarali@uetpeshawar.edu.pk](mailto:drqaisarali@uetpeshawar.edu.pk)

[www.drqaisarali.com](http://www.drqaisarali.com)



# Lecture Contents

- General
- Design of Concrete Floor Systems
- Design of One-way Slab System
- General Design Procedure
- Design of 90' X 60' Hall (Example)
- Case Studies
- References



# Learning Outcomes

- ❑ **At the end of this lecture, students will be able to;**
  - **Classify** Concrete Floor Systems.
  - **Choose** different framing systems for structures.
  - **Analyze** and **Design** one-way slabs for flexure by ACI Approximate coefficients method.
  - **Recall** basic design steps of shear and flexure.
  - **Understand** the effect of beams' spacing on slab moments.



# General

## □ Concrete Floor Systems

- In reinforced concrete construction, Concrete Floor Systems are broad and flat plates, usually horizontal, with top and bottom surfaces parallel or nearly so.
- They are used to provide flat and useful surfaces. They may be supported by:
  - Reinforced concrete beams
  - Masonry or reinforced concrete walls
  - Structural steel members
  - Columns
  - Ground.



# General

## □ Classification of Concrete Floor Systems

### 1. Flat Plate

- Concrete floors directly supported on columns (with no beams) are called flat plates.
- Punching shear is a typical problem in flat plates.

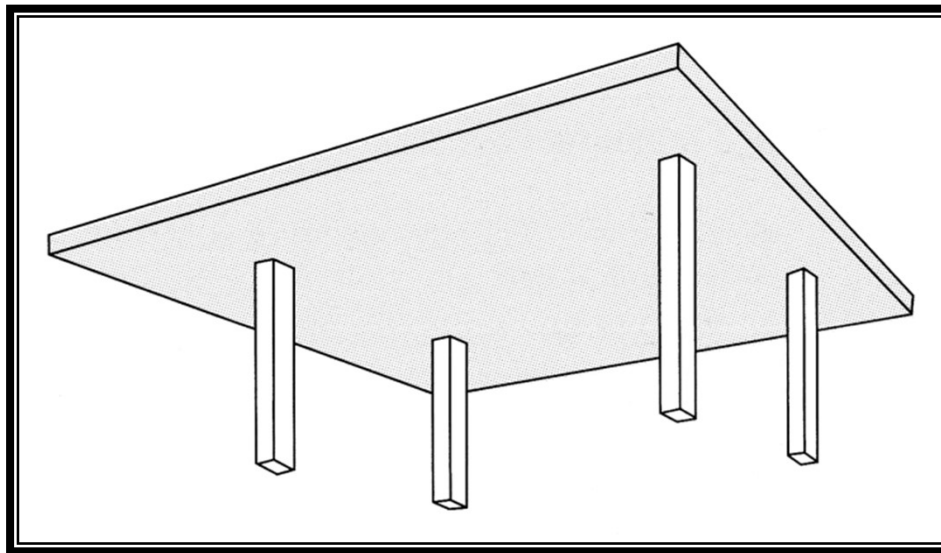



# General

## ❑ Classification of Concrete Floor Systems

### 2. Flat Slab

- A flat plate that has a column capital or a drop panel is referred to as a flat slab.
- The drop panel and column capital are intended to reduce the punching shear problem.

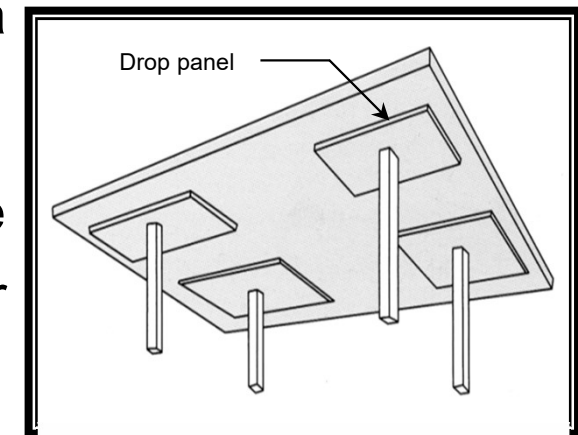

- Drop panel is a projection of slab at the vicinity of column.
- Column capital is a widening of the top of a support column where it meets the soffit of a slab.

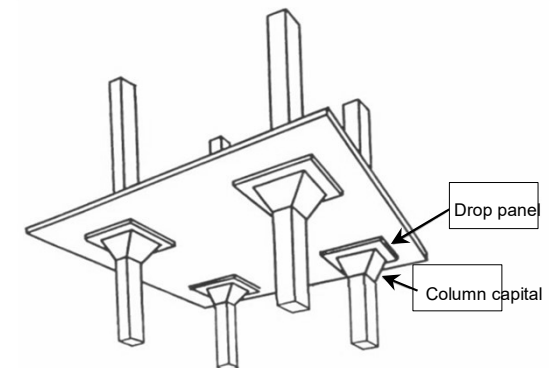



# General

## □ Classification of Concrete Floor Systems

### 3. One-way Joist System

- Joist construction consists of a monolithic combination of regularly spaced ribs with clear spacing of 3' and a top slab arranged to span in one direction or two orthogonal directions.

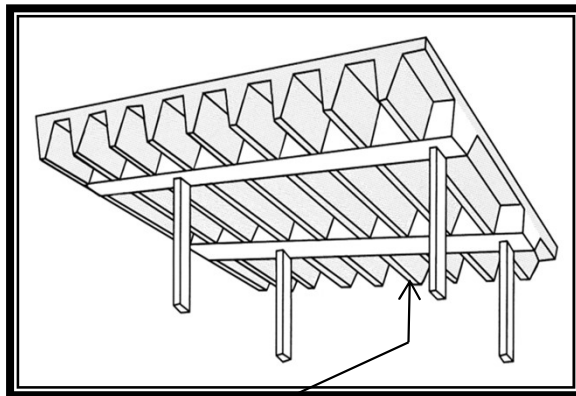

Rib



Peshawar University Auditorium





# General

## □ Classification of Concrete Floor Systems

### 4. Two-way Joist System

- A two-way joist system, or waffle slab, comprises evenly spaced concrete joists spanning in both directions and a reinforced concrete slab cast integrally with the joists.
- Like one-way joist system, a two-way system will be called as two-way joist system if clear spacing between ribs (dome width) does not exceed 30 inches.





# General

## □ Classification of Concrete Floor Systems

### 4. Two-way Joist System

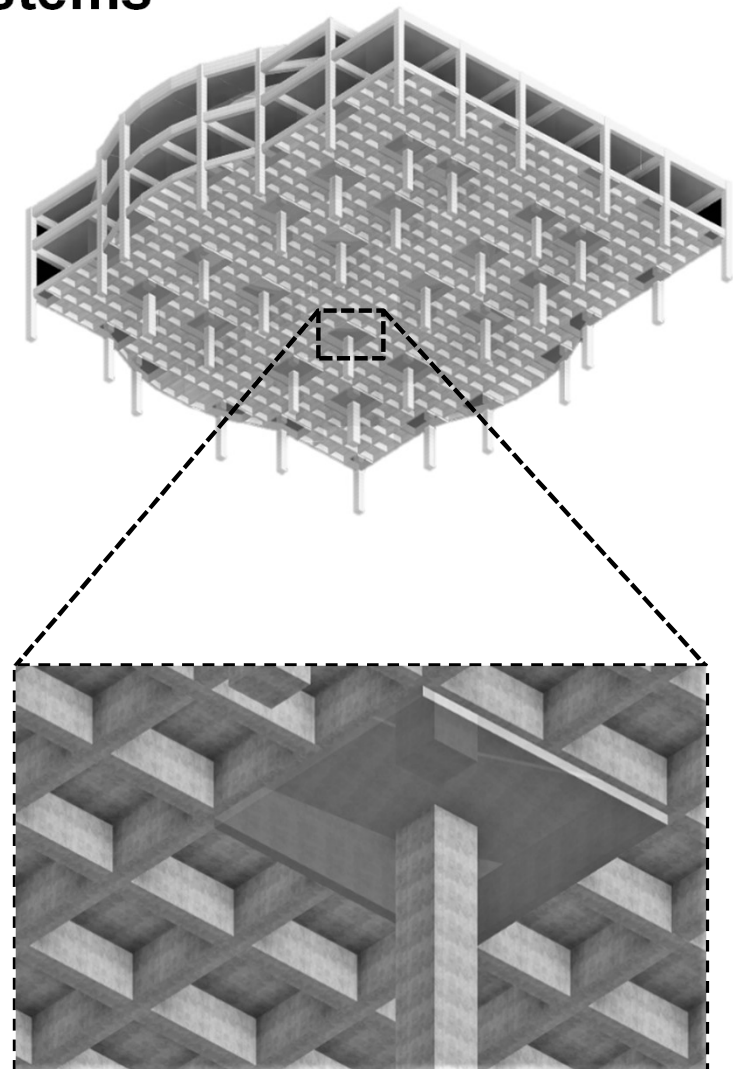



# General

## □ Classification of Concrete Floor Systems

### 5. Beam-supported Slab Systems

- Slabs may be supported on two opposite sides only, or on all four sides.
- Based on the behavior of bending, there are two types of such slabs:
  - a. One-way slabs (bending in one direction)
  - b. Two-way slabs (bending in two direction)
- Both types will be discussed in detail later.



# Design of Concrete Floor Systems

## □ Analysis

- Unlike beams and columns, Concrete Floors Systems are two dimensional members. Therefore, their analysis except one-way slab systems is relatively difficult.

## □ Design

- Once the analysis is done, the design is carried out in the usual manner. Hence there is no problem in design, problem is only in analysis of slabs.



# Design of Concrete Floor Systems

## □ Methods of Concrete Floor Analysis

### 1. Analysis using computer software (FEA)

- SAP 2000
- ETABS
- SAFE and so on.

### 2. ACI Approximate Method of Analysis

- Strip Method
  - ACI Approximate Coefficients Method
  - Moment Coefficient Method
  - Direct Design Method (DDM)
- } For One-way Slabs
- } For Two-way Slabs



# Design of One-way Slab System

## □ Definition (case I)

- Slab supported on two opposing sides only is called one-way slab.
- In such case, the bending occurs perpendicular to the supports as shown in the following figures.

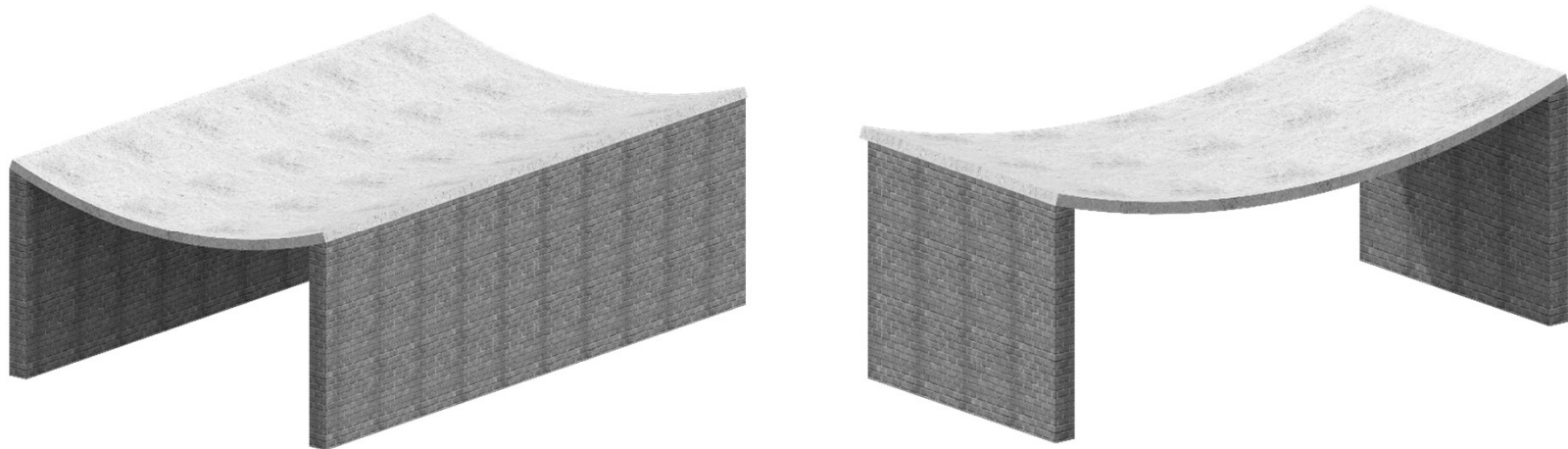

Bending behavior of one-way slab



# Design of One-way Slab System

## □ Definition (case II)

- When the ratio of long to short span in a slab supported on all sides is equal to or greater than 2 the slab is called one-way slab.
- Because the major bending moment is always along the short direction, these slabs are solely designed for the short direction.

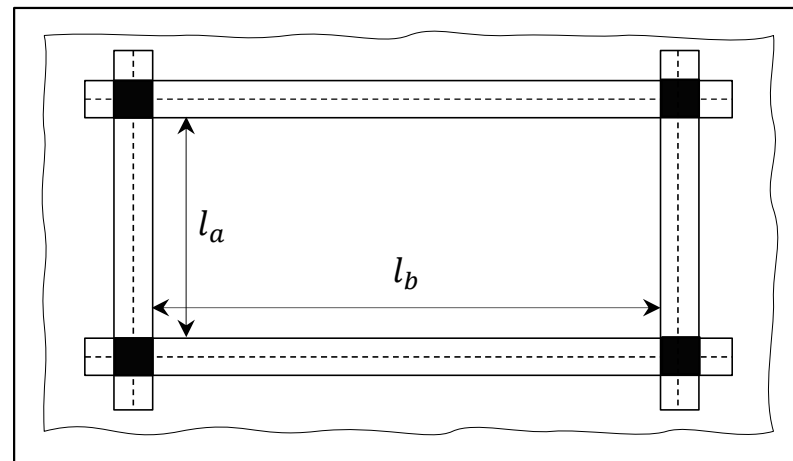

Slab supported on all sides, but  $\beta = l_b/l_a \geq 2$

Animation



# Design of One-way Slab System

## □ Strip Method of Analysis

- For the purpose of analysis and design, a unit strip of one-way slab, cut out at right angles to the opposing beams, may be considered as a rectangular beam of unit width, with a depth  $h$  and a span  $l_a$  as shown in figure.
- This method is called as strip method of analysis.

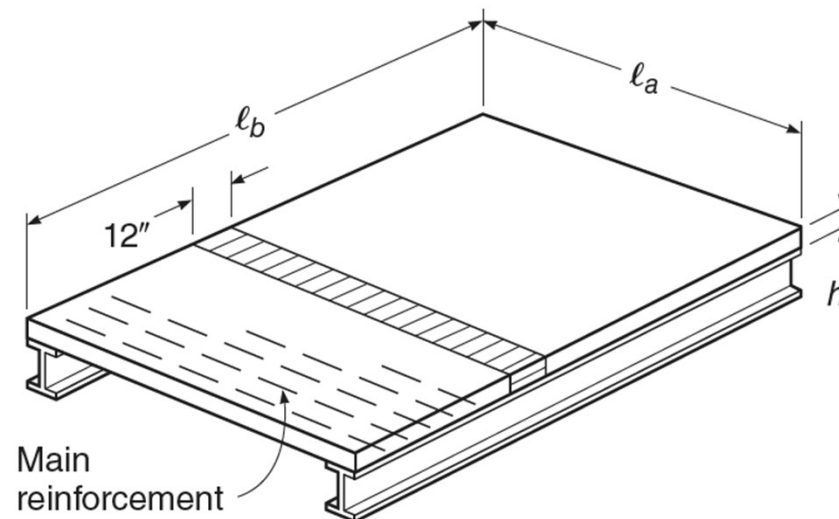



# Design of One-way Slab System

## □ Limitations of Strip Method of Analysis

- Applicable for one-way slabs only.
- Requires the slab to be supported on stiff beams or walls.
- It is not applicable to flat plates etc., even if bending is in one direction.





# Design of One-way Slab System

## □ ACI Approximate Coefficients Method

- According to ACI 6.5.1, as an alternate to frame analysis, ACI approximate moments shall be permitted for analysis of one-way slabs with certain restrictions.
- This method is discussed in following slides.



# Design of One-way Slab System

## ACI Approximate Moment Coefficients

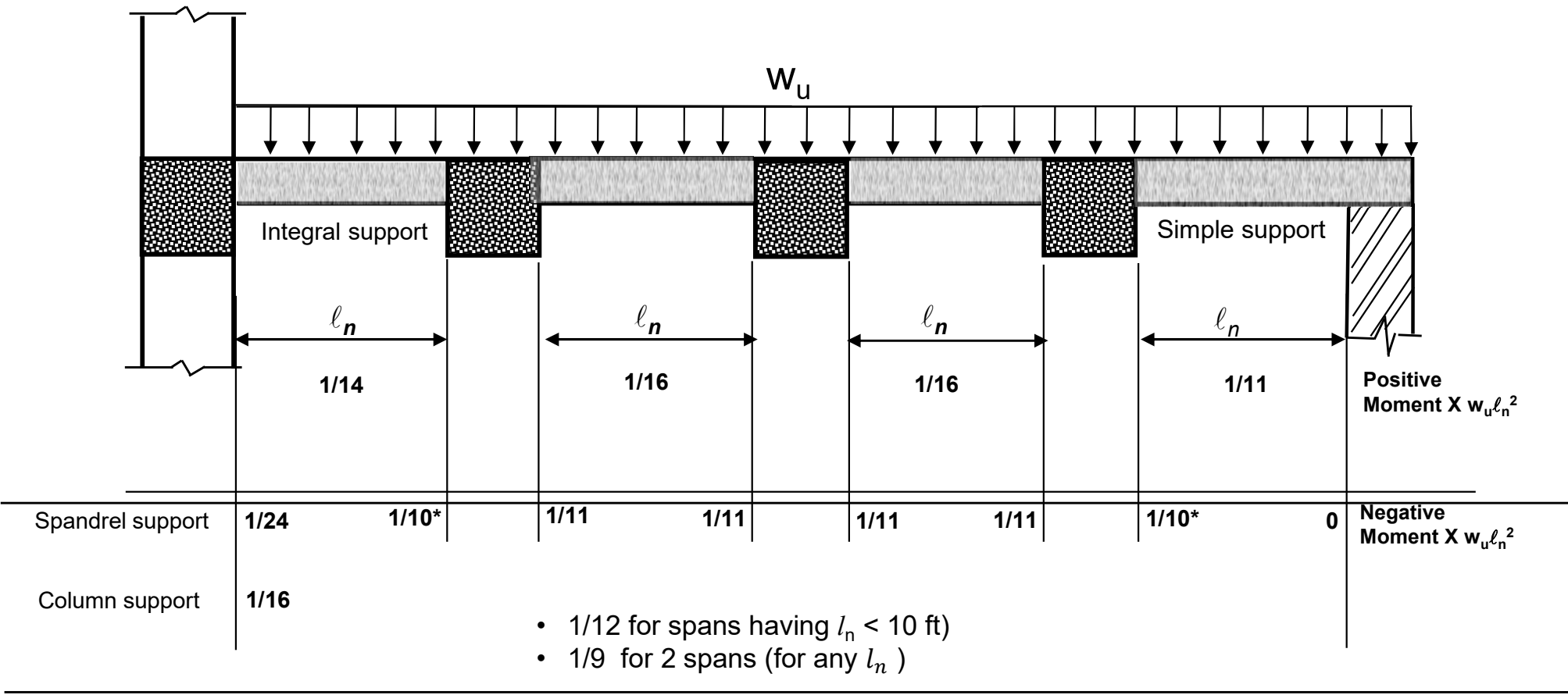

Note: (i) For simply supported members,  $M = w_u l^2 / 8$ , where  $l$  = center to center distance.  
 (ii) To calculate negative moments,  $l_n$  shall be the average of the adjacent clear span lengths.



# Design of One-way Slab System

## □ ACI Approximate Shear Coefficients

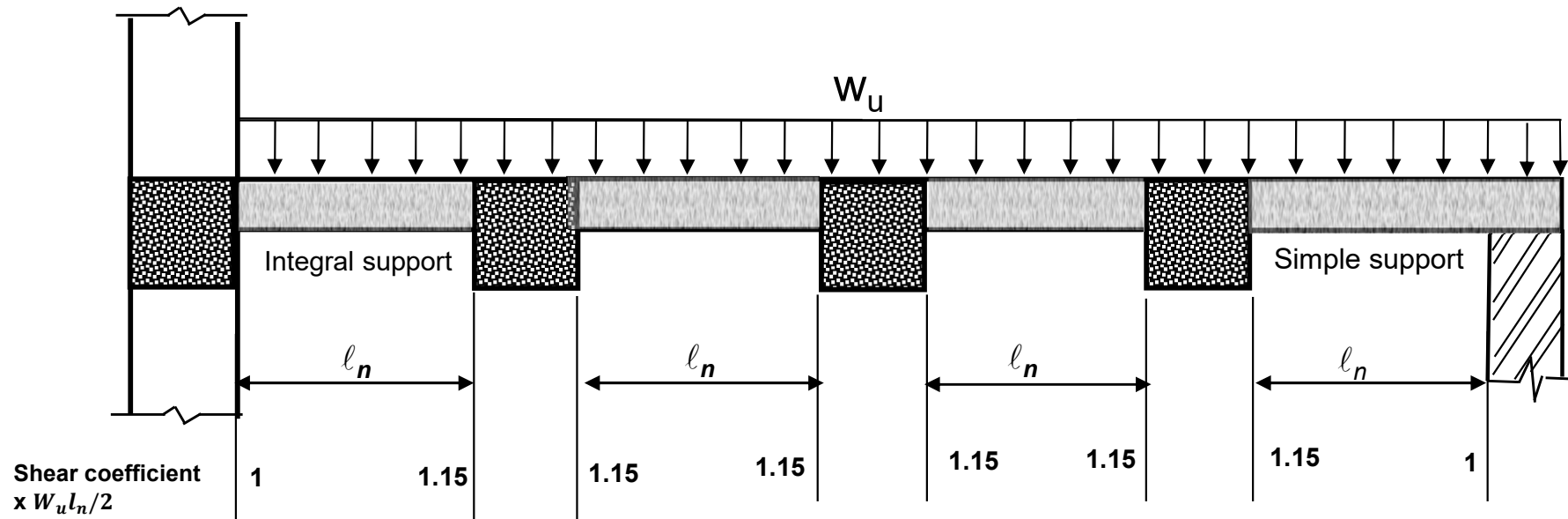

Note:

The above co-efficient is used for shear in beam only as slab has no significant shear.



# Design of One-way Slab System

## □ Limitations ACI Approximate Coefficients Method

1. Applicable to One-way Slabs and Beams only.
2. Loads must be uniformly distributed; not applicable for point loads.
3. The ratio of service live load to service dead load shall not exceed 3 ( $L/D \leq 3$ ).
4. Suitable for two or more spans.
5. Members must be prismatic.



# Design of One-way Slab System

## □ Limitations ACI Approximate Coefficients Method

6. The longer of two adjacent spans does not exceed the shorter by more than 20 percent.

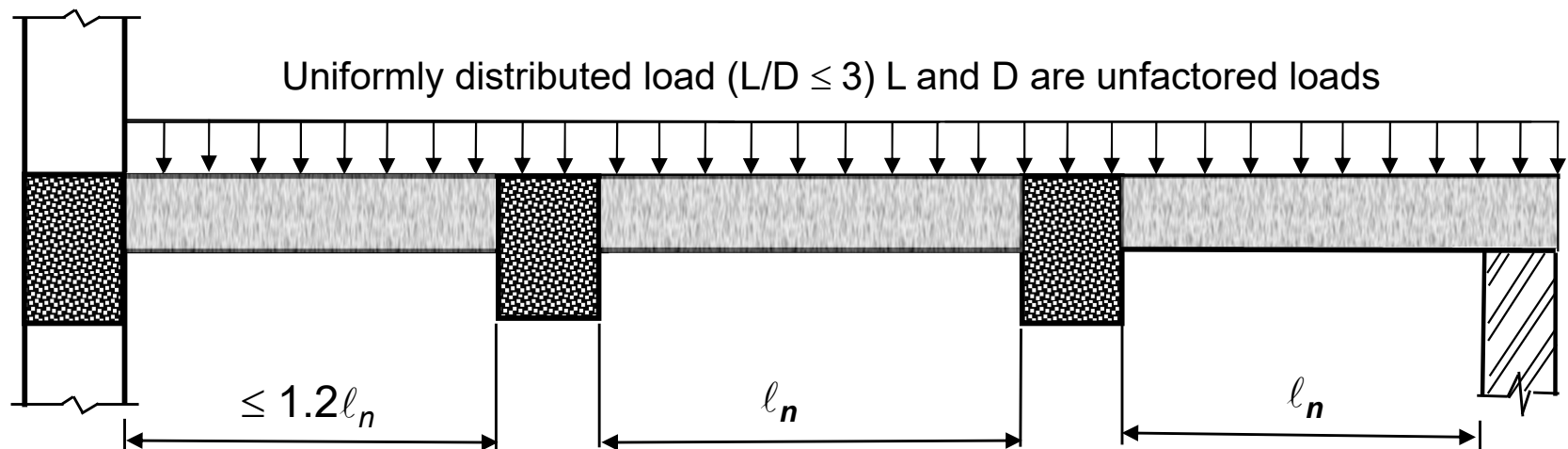



# General Design Procedure

## □ Steps in the Design of a Typical RC Structure

1. Selection of Structural Configuration
2. Selection of sizes
3. Calculation of Loads
4. Analysis (Calculating Ultimate load effects/stresses)
5. Determination of Steel Area
6. Detailing of reinforcement
7. Drafting of structural members



# General Design Procedure

## 1. Selection of Structural Configuration

- The very first and most important step in Reinforced Concrete design is to choose an appropriate structural configuration for the given structure.
- Structural configuration means reasonable arrangement of beams, girders and columns.
- Because several alternatives exist for a single structure, selecting a suitable and cost-effective configuration is quite challenging.
- It is primarily determined by the designer's prior experience.



# General Design Procedure

## 2. Selection of Sizes

- ACI tables 7.3.1.1 & 9.3.1.1 give the minimum thickness for one-way slabs and beams, respectively.

Table 7.3.1.1 & Table 9.3.1.1– Minimum Thickness of Non-Prestressed Beams or One-way Slabs Unless Deflections are Computed				
Member	Minimum thickness, $h$ <sup>[1]</sup>			
	<i>Simply supported</i>	<i>One end continuous</i>	<i>Both ends continuous</i>	<i>Cantilever</i>
Solid one-way slabs	$l/20$	$l/24$	$l/28$	$l/10$
Beams or ribbed one-way slabs	$l/16$	$l/18.5$	$l/21$	$l/8$

- $l$  = Span length (Center to center length in case of interior spans and clear projection in case of cantilevers) (Section 2.2).
- [1] For  $f_y$  other than 60,000 psi, the expressions in the table shall be multiplied by  $(0.4 + f_y / 100,000)$





# General Design Procedure

## 3. Calculation of Loads

- According to ACI 5.2, service loads shall be in accordance with the general building code of which this code forms a part, with such live load reductions as are permitted in the general building code.
- BCP SP 2007 is General Building Code of Pakistan, and it refers to ASCE 7-10 for minimum design loads for buildings and other structures.



# General Design Procedure

## 4. Analysis

- The analysis is carried out for ultimate load including self weight obtained from size of the slab and the applied dead and live loads.
- The maximum demand values are used for the purpose of design.



# General Design Procedure

## 5. Determination of Steel Area

- Once the load effects (Bending moment, Shear force, Axial force and Torsion ) are calculated based on the anticipated loads, the next step is to calculate the required area of steel to withstand these load effects.
- The steel area can be determined by equating design capacity of a structural member with demand.



# General Design Procedure

## 6. Detailing

- The calculated steel area is detailed as per the Code Provisions.
- The detailing step involves development lengths, steel curtailment, splices, symmetrical arrangement of rebars, spacing requirements etc.

## 7. Drafting

- Drafting is the final stage in the design which is the proper sketch of dimensions and reinforcement detailing of a structural member in different views.



# Design of 90' x 60' Hall

## □ Example 2.1

- The slab of a Hall having interior dimensions 90' × 60' with story height of 20' is subjected to a uniform service live load of 40 psf. Additionally, the slab includes superimposed dead load in the form of 3-inch mud layer and 2-inch tile layer. The allowable bearing capacity of soil at the depth of 5 ft. from finished floor level is 2.204 ksf. For all structural members, consider concrete compressive strength,  $f'_c = 3 \text{ ksi}$  and steel yield strength,  $f_y = 60 \text{ ksi}$
- **Design** the Hall with various structural configurations.



# Design of 90' x 60' Hall

## □ Given Data

Dimensions of Hall : 90' x 60' (interior)

Story height,  $h = 20'$

Loads:

➤ SDL: 3" Mud layer and 2" Tile layer

➤ Live load: 60 psf

$$f'_c = 3 \text{ ksi}$$

$$f_y = 60 \text{ ksi}$$

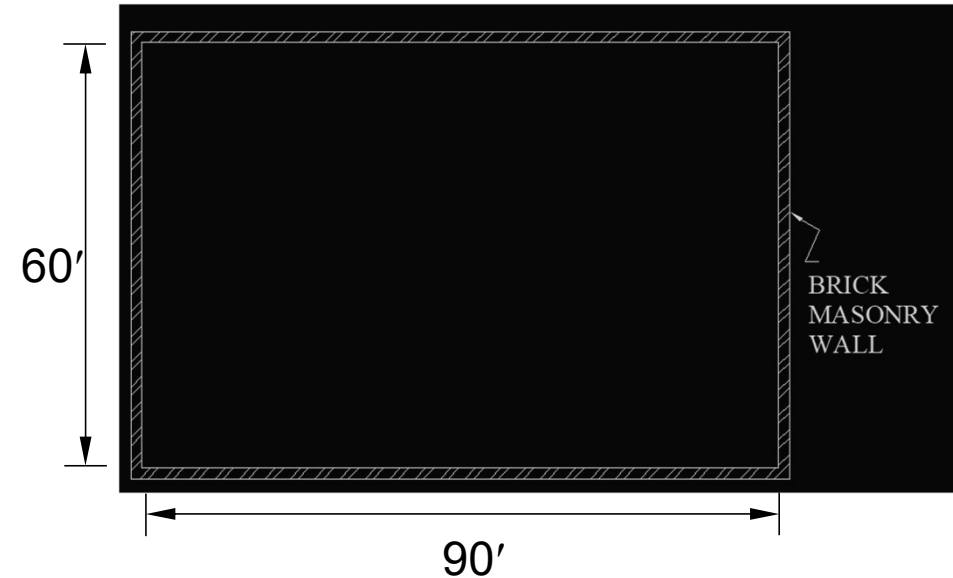

## □ Required Data

Design the Hall with various structural configurations.



# Design of 90' x 60' Hall

## □ Solution

- Several structural configurations are possible for the given hall, some of which are shown below

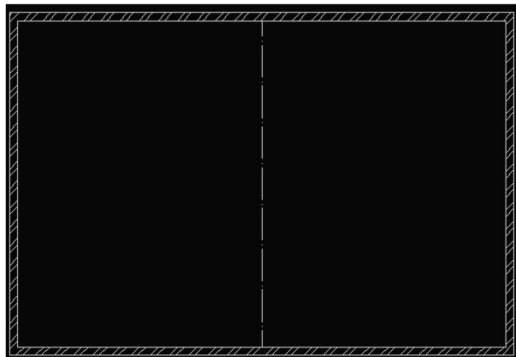

1

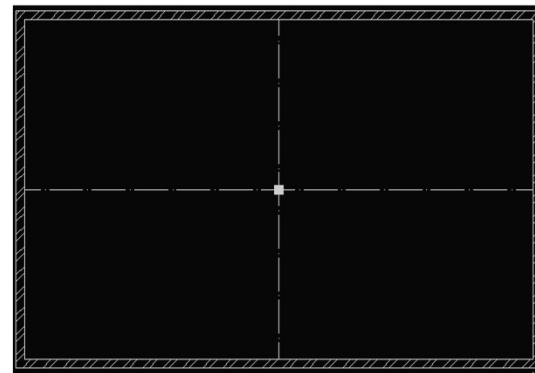

2

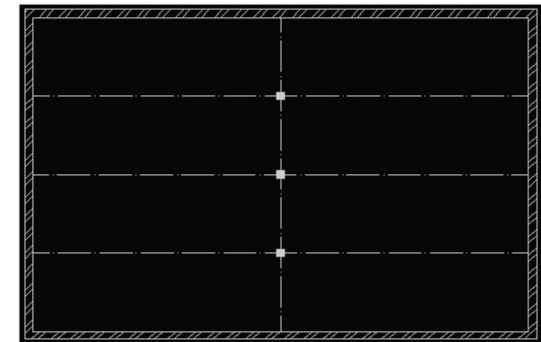

3



# Design of 90' x 60' Hall

## □ Solution

- Several structural configurations are possible for the given hall, some of which are shown below

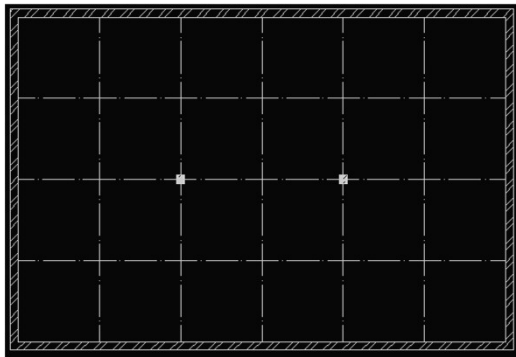

4

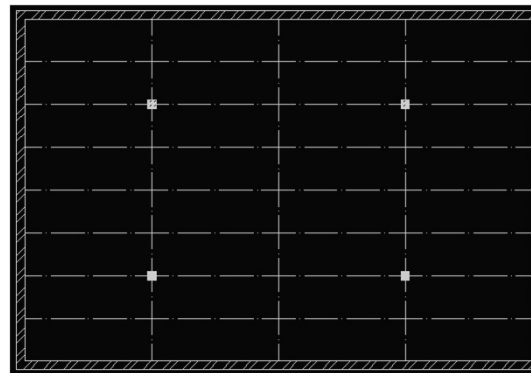

5

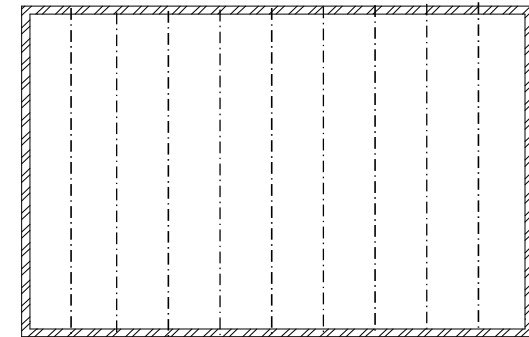

6

and many more...





# Design of 90' x 60' Hall

## □ Solution

- However, in this lecture we will explore the following design options:

### 1. Option 1: Hall Design Without Interior Columns

- a) Beam-slab system supported on walls.
- b) Beam-slab system supported on exterior columns.

### 2. Option 2: Hall Design With Only Two Interior Columns

- a) Beam-slab system supported on girder and walls.
- b) Beam-slab system supported on girder and exterior columns.



# **Design of 90' X 60' Hall**

## **Option 1a**



# Design of 90' x 60' Hall

## □ Solution [option 1a]

### ➤ Step 1: Selection of Structural Configuration

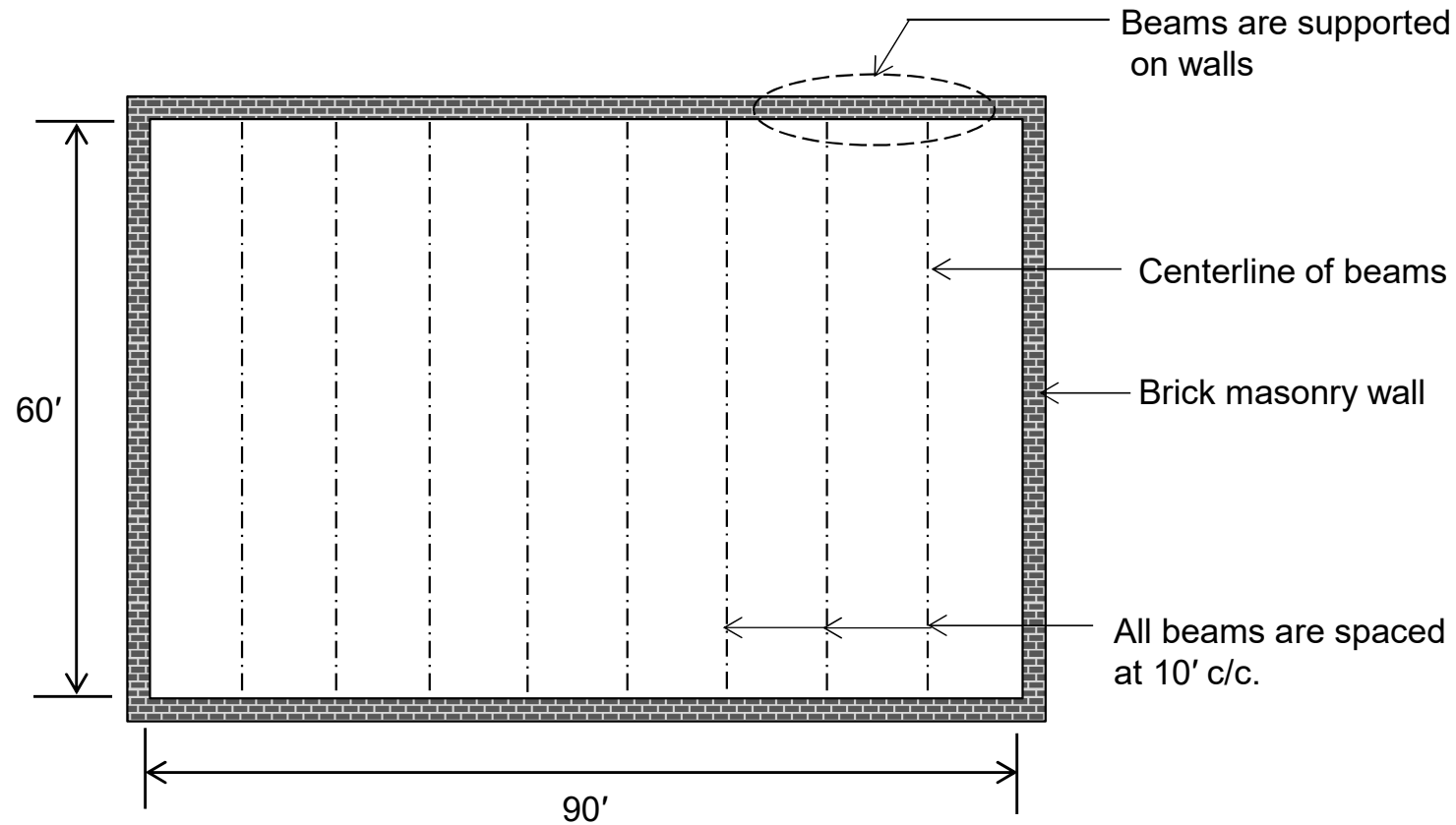



# Design of 90' x 60' Hall

## □ Solution [option 1a]

### ➤ Step 1: Selection of Structural Configuration

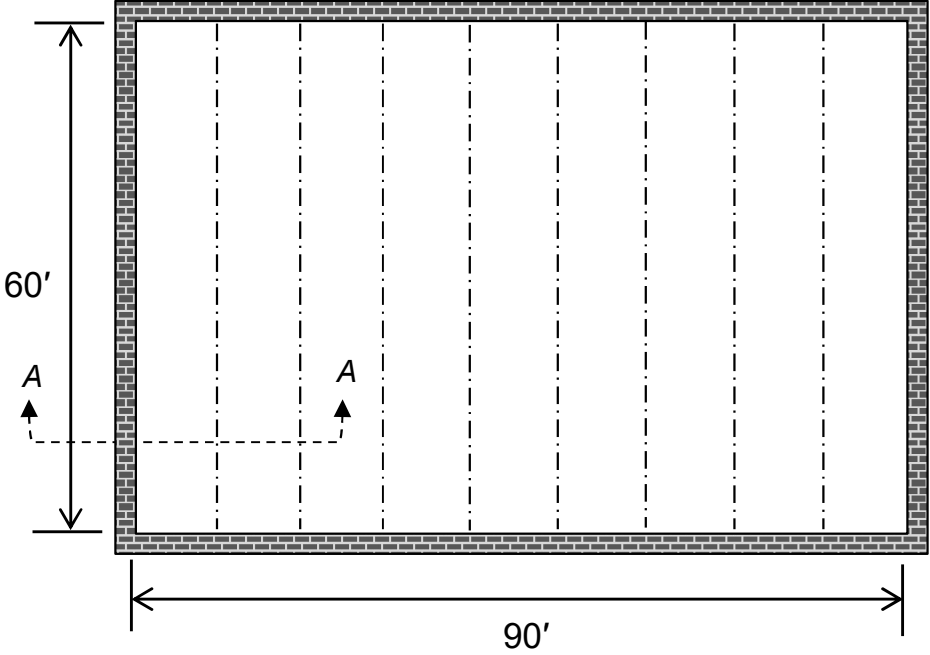

Assumed wall thickness = 18 in  
 Assumed beam width = 18 in

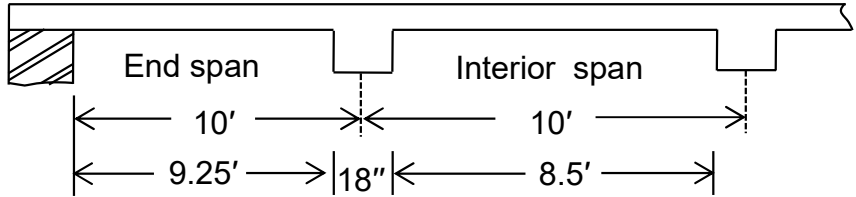
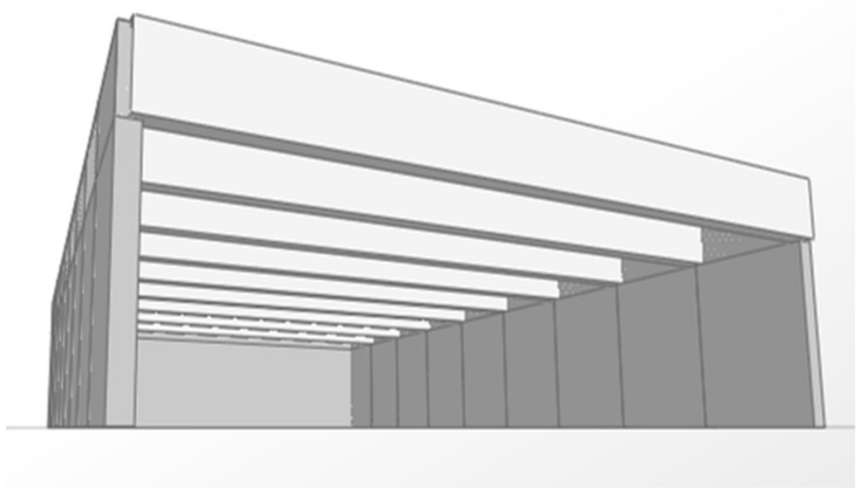

Section A-A



# Design of 90' x 60' Hall

## □ Solution [option 1a]

### ❖ Slab Design

#### ● Step 2: Selection of Sizes

$$h_{\min,1} = \frac{l}{24} \quad (\text{for one end continuous slab})$$

$$= \frac{10.75}{24} = 0.448' \text{ or } 5.4''$$

$$h_{\min,2} = \frac{l}{28} \quad (\text{for both end continuous slab})$$

$$= \frac{10}{28} = 0.357' \text{ or } 4.3''$$

$$h_{\min} = \text{larger of } (h_{\min,1}, h_{\min,2}) = 5.4'' . \text{ Finally take } h = 6''$$

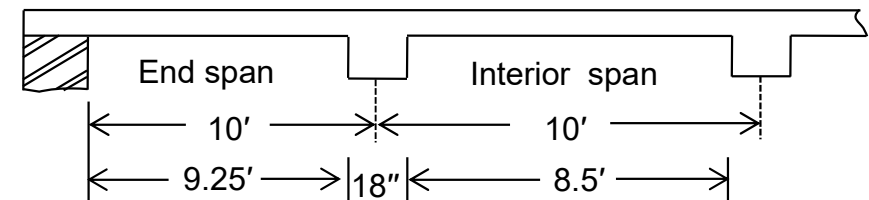

Section A-A



# Design of 90' x 60' Hall

## □ Solution [option 1a]

### ❖ Slab Design

### ➤ Step 3: Calculation of Loads

Calculation of Dead Loads			
Material	Thickness h (in.)	Unit weight $\gamma$ (kcf)	$h \times \gamma$ (ksf)
Concrete	6	0.150	$(6/12) \times 0.15 = 0.075$
Mud	3	0.120	$(3/12) \times 0.12 = 0.03$
Tile	2	0.120	$(2/12) \times 0.12 = 0.02$
Total dead load =			0.125 ksf

- Factored Load,  $w_{u,slab} = 1.2D + 1.6L$   

$$= 1.2 \times 0.125 + 1.6 \times 0.04 = 0.214 \text{ ksf}$$



# Design of 90' x 60' Hall

## □ Solution [option 1a]

### ❖ Slab Design

- Before proceeding to the analysis step, there is an important notion that needs clarification.
- The ACI Coefficients give reasonably accurate results only when the supports (beams or walls), exhibit sufficient stiffness.
- However, it must be kept in mind that; *“Beams of any depth cannot act as support to slabs; only beams with Specific depth can do so.”*
- The subsequent slides elaborate the above statement.



# Design of 90' x 60' Hall

## □ Solution [option 1a]

### ❖ Slab Design

- Relative Stiffness of Slab and Beam-Slab Behavior.

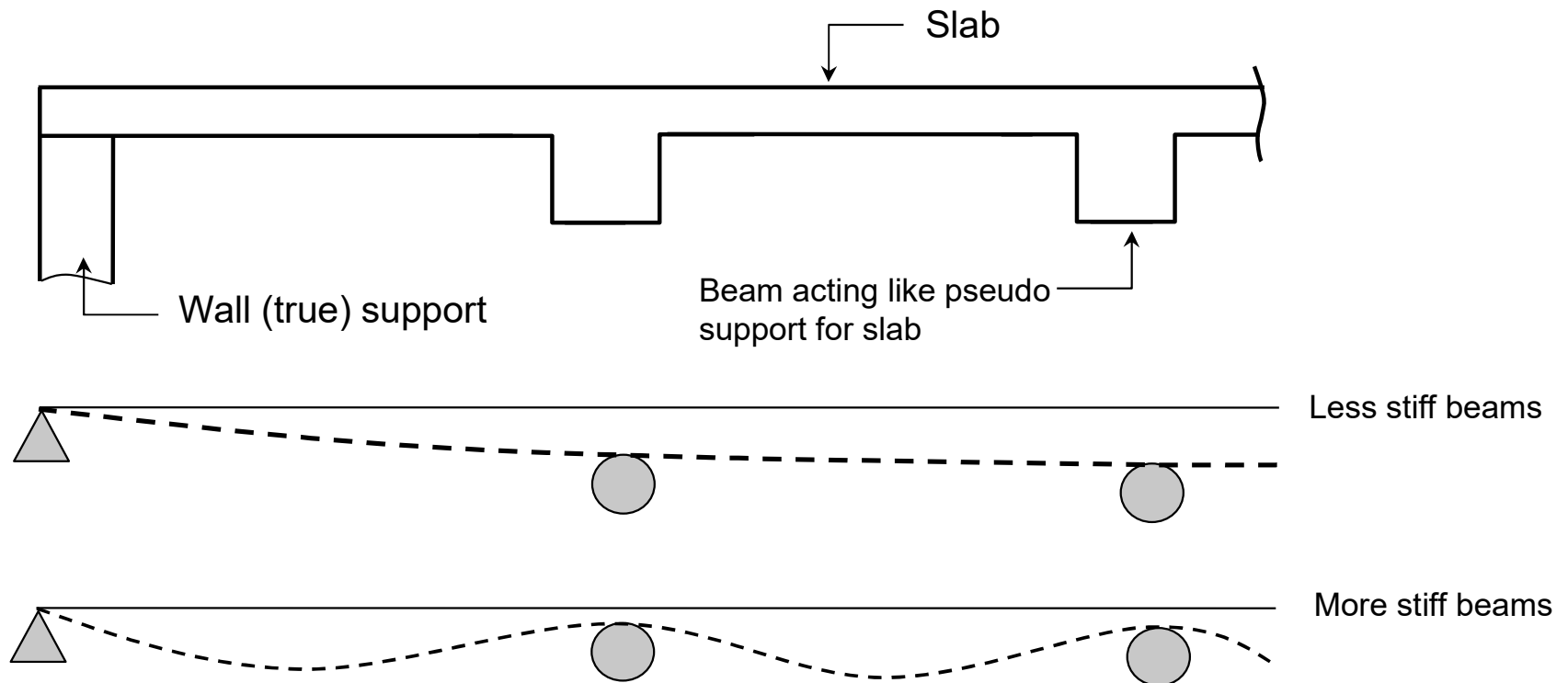





# Design of 90' x 60' Hall

## □ Solution [option 1a]

### ❖ Slab Design

- Behavior of flexible (Less stiff) beams.



Before Bending



After Bending



# Design of 90' x 60' Hall

## □ Solution [option 1a]

### ❖ Slab Design

- Behavior of stiff beams.

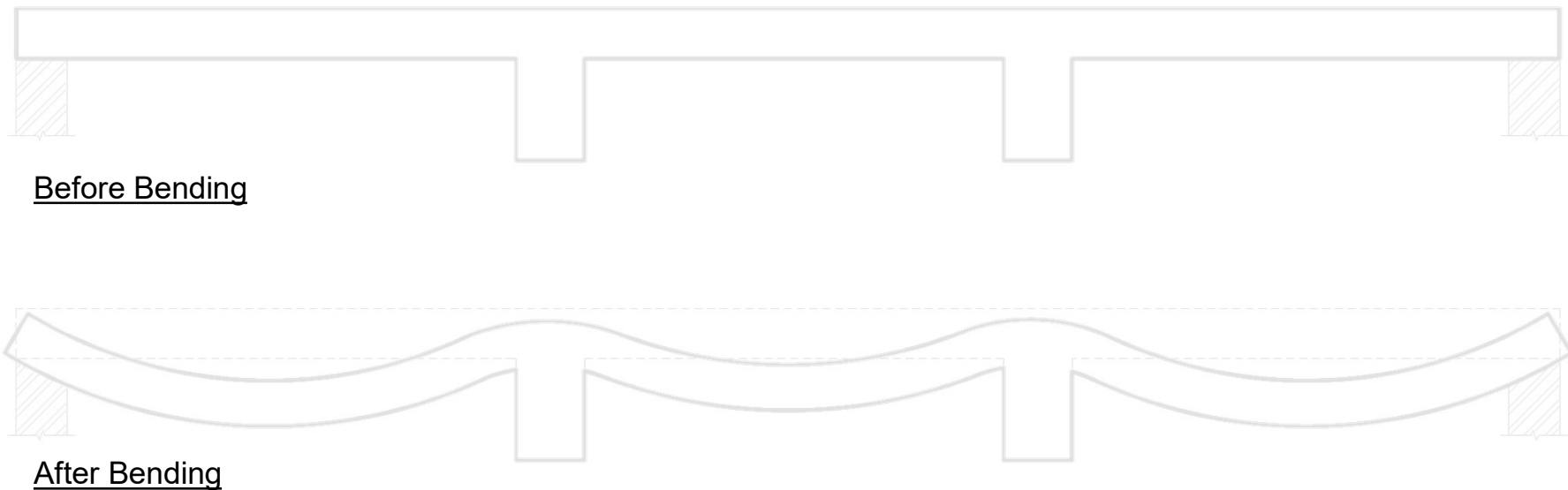

Animation on relative Stiffness



# Design of 90' x 60' Hall

## □ Solution [option 1a]

### ❖ Slab Design

- The question that arises is how to determine the necessary beam depth to effectively support and minimize deflection in slabs.
- The required beam depth is determined by plotting the depth of the beam against the negative moments in the slab, as illustrated below.

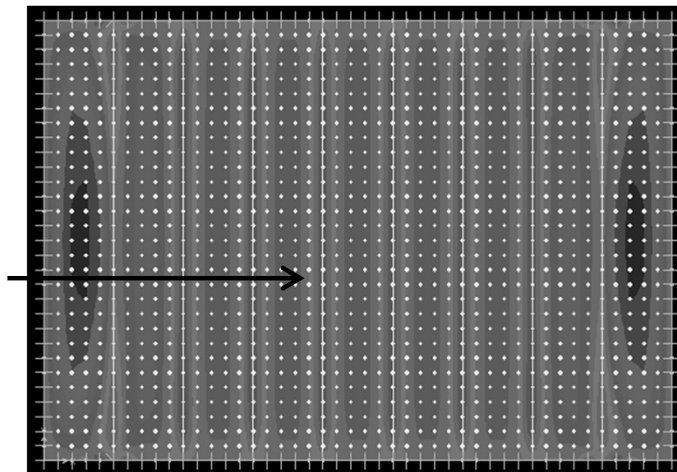
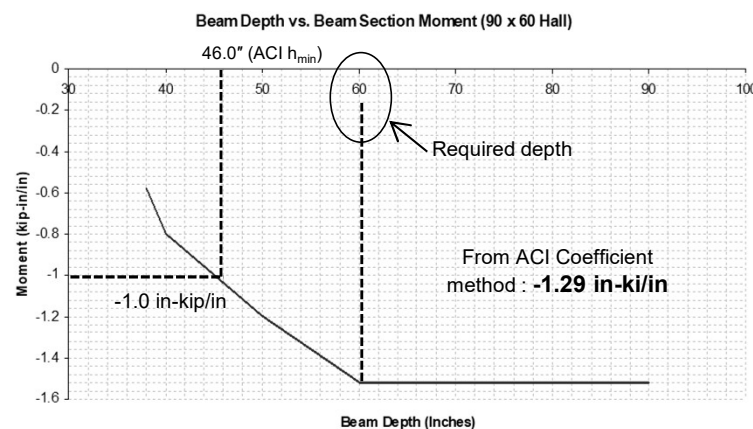



# Design of 90' x 60' Hall

## □ Solution [option 1a]

### ❖ Slab Design

#### ● Concluding Remarks

- From the plot, it is cleared that ACI minimum depth equations for beams may not always offer adequate stiffness under all circumstances. These equations are specifically applicable to beams with normal load conditions and typical spans.
- A beam depth of 60 inches is considered adequate to provide the necessary stiffness for the slab.

**Note:** The determination of the necessary beam depth to act as support for the slab depends on serviceability requirements, which is beyond the scope of this course.



# Design of 90' x 60' Hall

## □ Solution [option 1a]

### ❖ Slab Design

#### ➤ Step 4: Analysis

- When using 60" deep beams, the ACI coefficient method can be applied. The results obtained are displayed in the figure.

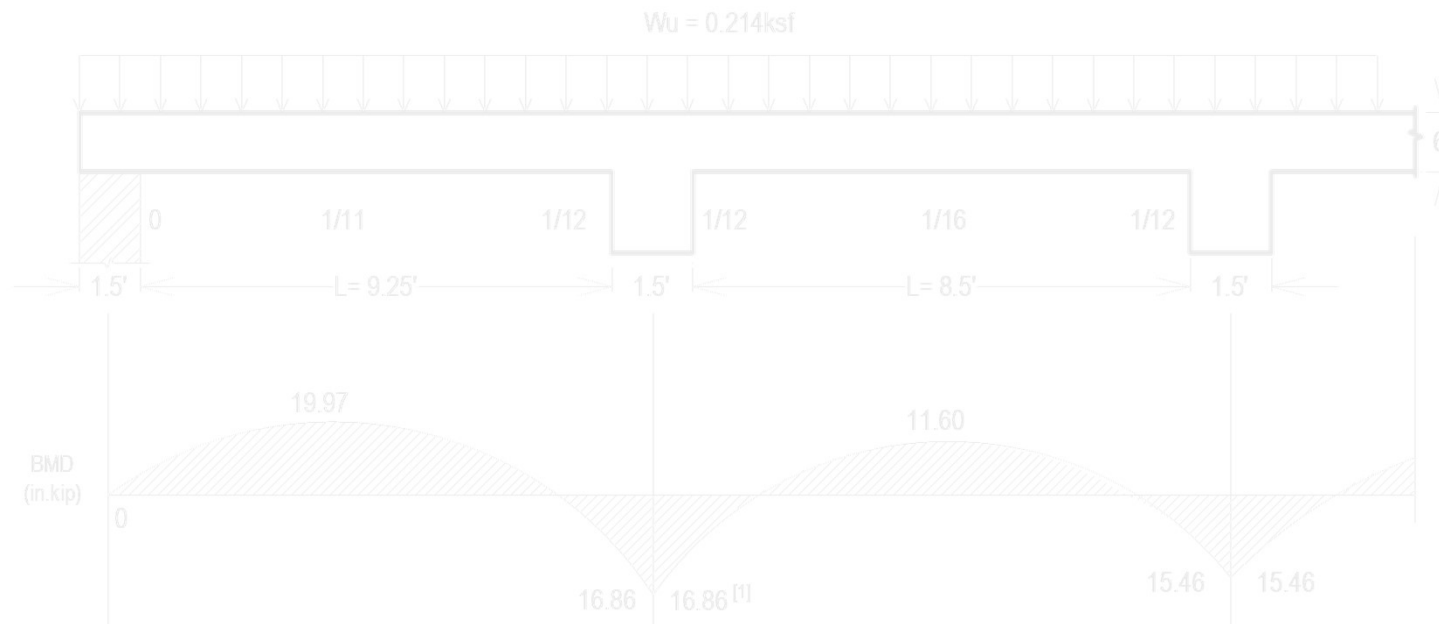

[1] For calculating negative moments,  $\ell_n$  shall be the average of the adjacent clear span lengths (ACI:6.5.2)



# Design of 90' x 60' Hall

## □ Solution [option 1a]

### ❖ Slab Design

#### ➤ Step 5: Determination of Flexural Steel Area

- Calculate moment capacity provided by minimum reinforcement

$$A_{s,min} = 0.0018bh = 0.0018(12)(6) = 0.129 \text{ in}^2/\text{ft}$$

$$a = \frac{A_{s,min}f_y}{0.85f_c'b_w} = \frac{0.129 \times 60}{0.85 \times 3 \times 12} = 0.253 \text{ in.}$$

$$\begin{aligned} \phi M_n &= \phi A_{s,min}f_y \left( d - \frac{a}{2} \right) = 0.9 \times 0.129 \times 60 \left( 5 - \frac{0.253}{2} \right) \\ &= 33.95 \text{ in. k/ft} \end{aligned}$$



# Design of 90' x 60' Hall

## □ Solution [option 1a]

### ❖ Slab Design

#### ➤ Step 5: Determination of Flexural Steel Area

- $\phi M_n$  calculated from  $A_{s,min}$  is greater than all moments calculated in Step No 4. Hence Minimum reinforcement governs.

$$A_s = 0.129 \text{ in}^2/\text{ft}$$

Using #3 bar with  $A_b = 0.11 \text{ in}^2$

$$s = \frac{12A_b}{A_s} = \frac{12(0.11)}{0.129} = 10.2 \text{ in.}$$

- Provide #3 bars @ 10.2 in. c/c for both positive and negative steel.



# Design of 90' x 60' Hall

## □ Solution [option 1a]

### ❖ Slab Design

#### ➤ Step 5: Determination of Flexural Steel Area

$s_{max} = 3h$  or 18" whichever is greater

$s_{max} = 3(6)$  or 18" = 18" → OK!

Finally, provide #3 bars @ 9 in. c/c

- Shrinkage and Temperature reinforcement

$A_{s+T} = A_{min} = 0.129 \text{ in}^2/\text{ft}$  (#3@9" c/c)

$s_{max} = 5(6)$  or 18" = 18" → OK!





# Design of 90' x 60' Hall

## □ Solution [option 1a]

### ❖ Slab Design

#### ➤ Step 6: Detailing

- Positive reinforcement bars are placed in the direction of flexure stresses and placed at the bottom to maximize the “d”.
- Negative reinforcement bars are placed perpendicular to the direction of support (beam in this case). At the support, these rest on the reinforcement of the beam.
- At the discontinuous end, the ACI code recommends to provide reinforcement equal to  $1/3$  times the positive reinforcement provided at the mid span.



# Design of 90' x 60' Hall

## □ Solution [option 1a]

### ❖ Slab Design

### ➤ Step 7: Drafting

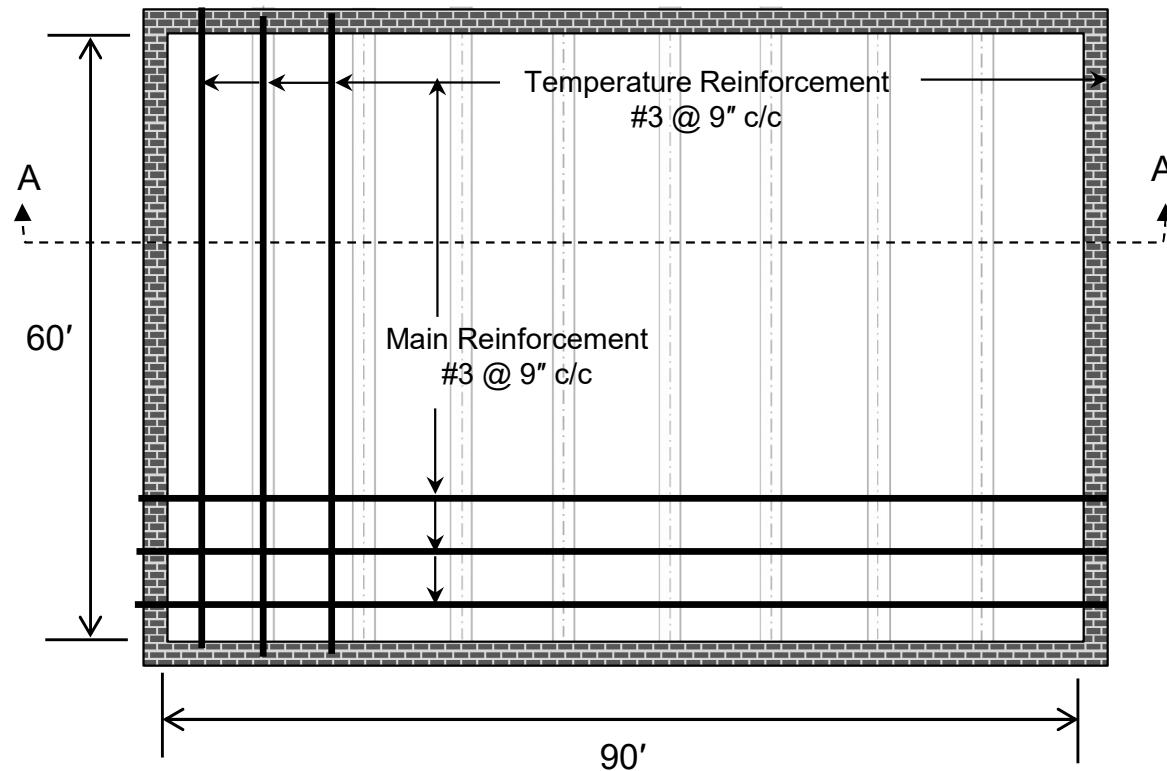



# Design of 90' x 60' Hall

## □ Solution [option 1a]

### ❖ Slab Design

### ➤ Step 7: Drafting

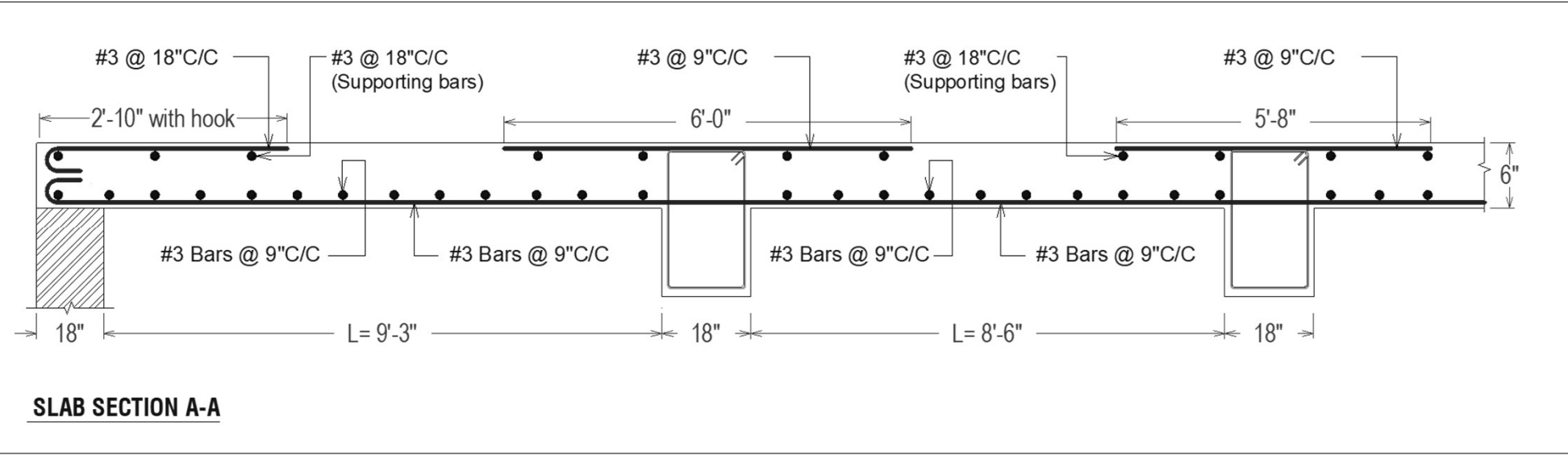



# Design of 90' x 60' Hall

## □ Solution [option 1a]

- Slab reinforcement arrangement at Site

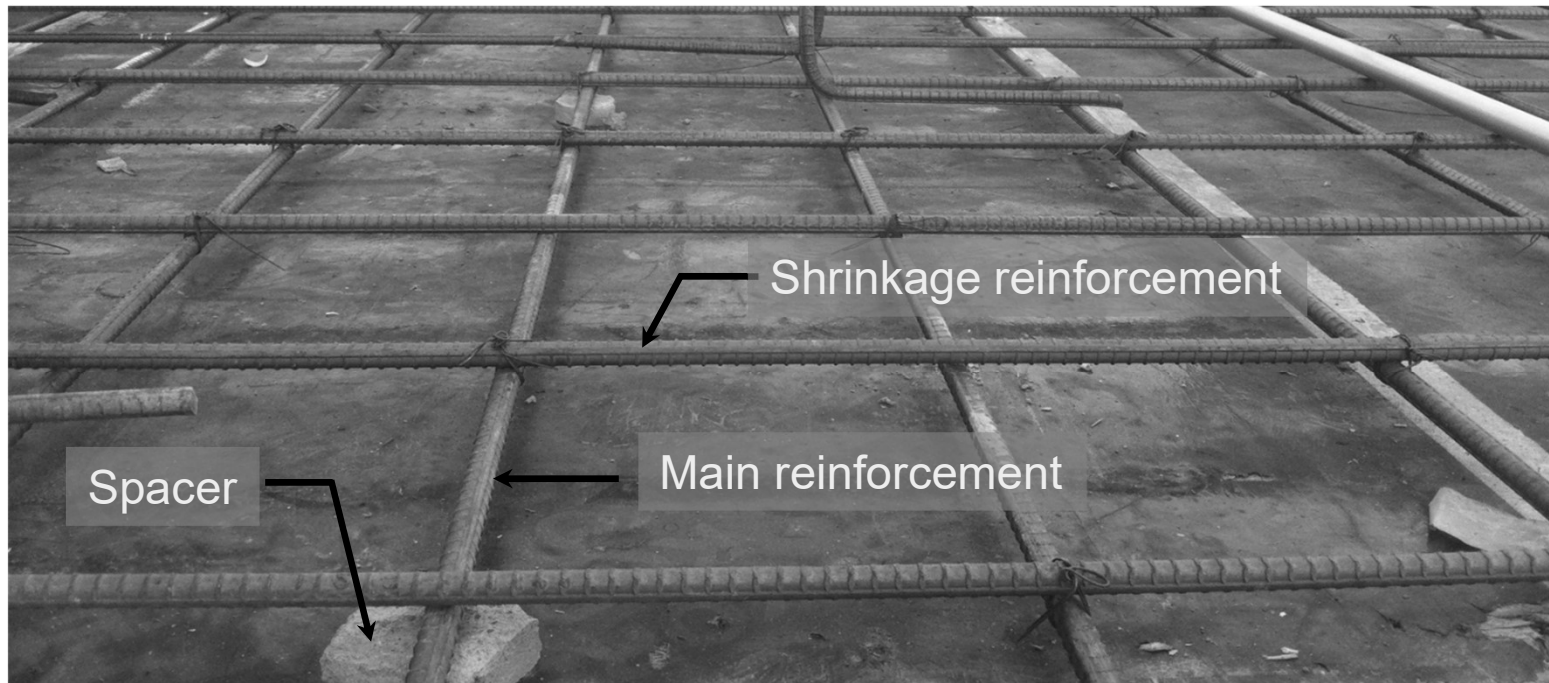



# Design of 90' x 60' Hall

## □ Solution [option 1a]

### ❖ Beam Design

#### ➤ Step 2: Selection of Sizes

- Assume 18" width of beam. The minimum depth of beam for a simply supported case is given by

$$h_{min} = \frac{l}{16} = \left[ \frac{60 + 2 \left( \frac{9}{12} \right)}{16} \right] = 3.84'$$

$$h_{min} = 46.08''$$

Take  $h = 60''$  (the reason is already explained earlier)

Effective depth,  $d = 60 - 3 = 57''$



# Design of 90' x 60' Hall

## □ Solution [option 1a]

### ❖ Beam Design

### ➤ Step 2: Selection of Sizes

Effective width of T-beam  $b_f$  is minimum of of:

- $b_w + 16h_f = 18 + 16(6) = 114"$
- $b_w + s_w = 18 + 8.5 \times 12 = 120"$
- $b_w + \frac{l_n}{4} = 18 + \frac{60}{4} \times 12 = 198"$

Therefore,  $b_f = 114"$

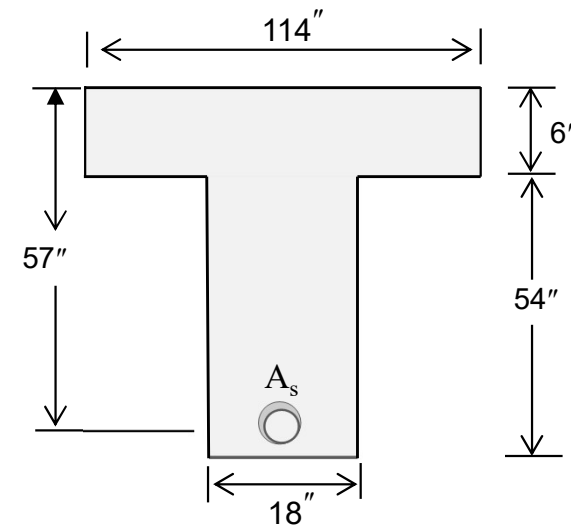



# Design of 90' x 60' Hall

## □ Solution [option 1a]

### ❖ Beam Design

#### ➤ Step 3: Calculation of Loads

- The factored load on the beam is the sum of the slab load and its own weight.

$$W_{u,beam} = \frac{(W_{u,slab} \times A_t)}{\text{Span length}} + 1.2SW$$

Which can be simplified to

$$W_{u,beam} = W_{u,slab} \times b_t + 1.2SW \text{ --- (2.1)}$$

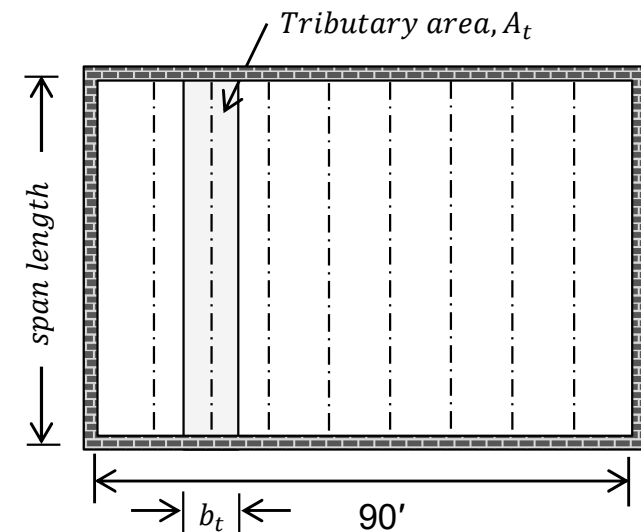



# Design of 90' x 60' Hall

## □ Solution [option 1a]

### ❖ Beam Design

#### ➤ Step 3: Calculation of Loads

$$SW = \frac{b_w(h - h_f)}{144} \times \gamma_c$$

$$= \frac{18(60 - 6)}{144} \times 0.150 = 1.0125k/ft$$

Now,

$$W_{u,beam} = 0.214 \times 10 + 1.2(1.0125)$$

$$W_{u,beam} = 3.355k/ft$$

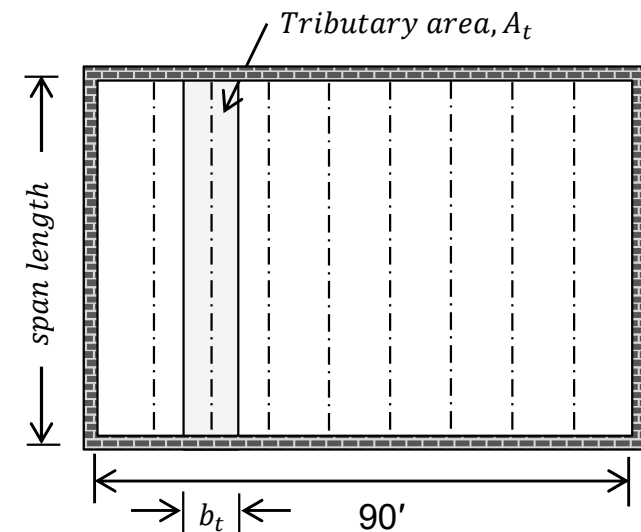





# Design of 90' x 60' Hall

## □ Solution [option 1a]

### ❖ Beam Design

### ➤ Step 4: Analysis

- Maximum shear force and bending moment is given by

$$V_u = 87.23 \text{ kip}$$

$$M_u = 19034.17 \text{ in. kip}$$

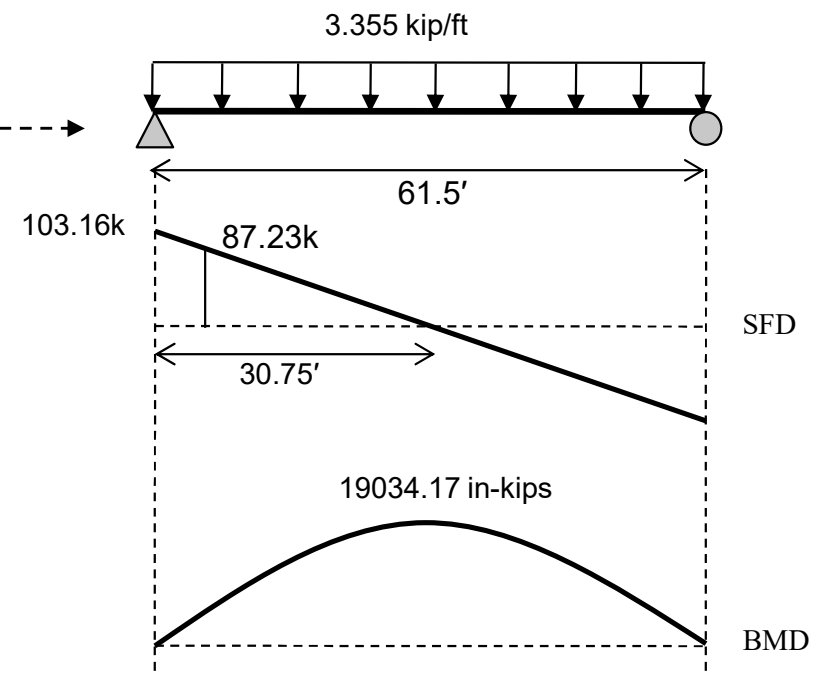
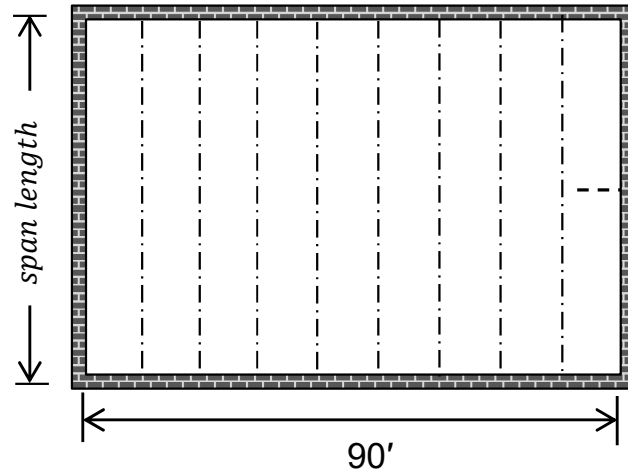



# Design of 90' x 60' Hall

## □ Solution [option 1a]

### ❖ Beam Design

#### ➤ Step 5: Determination of flexural steel area

Using direct method, we have

$$a = d - \sqrt{d^2 - \frac{2.614M_u}{f_c' b_f}} = 57 - \sqrt{57^2 - \frac{2.614 \times 19034}{3 \times 114}} = 1.29" < hf$$

The beam will be designed as rectangular.

$$A_s = \frac{M_u}{\phi f_y \left(d - \frac{a}{2}\right)} = \frac{19034}{0.9 \times 60 \left(57 - \frac{1.29}{2}\right)} = 6.25 \text{ in}^2 \text{ (8 \#8 bars)}$$



# Design of 90' x 60' Hall

## □ Solution [option 1a]

### ❖ Beam Design

#### ➤ Step 6: Check for flexural steel area

- Minimum reinforcement limit

$$A_{s,min} = \frac{200}{f_y} b_w d = \frac{200}{60000} \times 18 \times 57 = 3.42 \text{ in}^2$$

- Maximum reinforcement limit

$$A_{s,max} = \frac{f'_c b_w d}{223} = \frac{3 \times 18 \times 57}{223} = 13.8 \text{ in}^2$$

$$A_{s,min} < A_s < A_{s,max} \Rightarrow OK!$$



# Design of 90' x 60' Hall

## □ Solution [option 1a]

### ❖ Beam Design

#### ➤ Step 7: Determination of Shear reinforcement

$$\phi V_c = 2\phi\sqrt{f'_c}b_wd = \frac{2 \times 0.75\sqrt{3000} \times 18 \times 57}{1000} = 84.29 \text{ kip}$$

Calculate design spacing  $s_d$  using

$$s_d = \frac{\phi A_v f_y d}{V_u - \phi V_c}$$

Using 2 legged #3 stirrups,  $A_v = 2A_b = 2(0.11) = 0.22 \text{ in}^2$

$$s_d = \frac{0.75 \times 0.22 \times 60 \times 57}{87.23 - 84.29} = 191.94 \text{ in.}$$



# Design of 90' x 60' Hall

## □ Solution [option 1a]

### ❖ Beam Design

### ➤ Step 7: Determination of Shear reinforcement

Calculate maximum spacing  $s_{max}$

$$s_{max} = \text{Least of } \left\{ \begin{array}{l} \frac{A_v f_y}{50 b_w} = \frac{0.22 \times 60,000}{50 \times 18} = 14.7'' \\ \frac{A_v f_y}{0.75 \sqrt{f_c'} b_w} = \frac{0.22 \times 60,000}{0.75 \sqrt{3000} \times 18} = 17.9'' \\ \frac{d}{2} = \frac{57}{2} = 28.5'' \\ 24'' \end{array} \right. \left. \vphantom{\frac{A_v f_y}{50 b_w}} \right\} s_{max} = 14.7'' < s_d$$



# Design of 90' x 60' Hall

## □ Solution [option 1a]

### ❖ Beam Design

#### ➤ Step 7: Determination of Shear reinforcement

1. Check for Depth of Beam:

$$\phi V_s \leq \phi 8\sqrt{f_c'}b_wd \quad \phi V_s = \frac{0.75 \times 0.22 \times 60 \times 57}{14.7} = 38.39 \text{ kip}$$

$$\phi 8\sqrt{f_c'}b_wd = 4\phi V_c = 4 \times 84.29 = 337.16 \text{ kip} > \phi V_s \rightarrow OK!$$

2. Check for Maximum spacing of stirrups:

$$\phi V_s \leq \phi 4\sqrt{f_c'}b_wd \quad , \quad \phi V_s = 38.39 \text{ kip}$$

$$\phi 4\sqrt{f_c'}b_wd = 2\phi V_c = 2 \times 84.29 = 168.58 \text{ kip} > \phi V_s \rightarrow OK!$$



# Design of 90' x 60' Hall

## □ Solution [option 1a]

### ❖ Beam Design

#### ➤ Step 7: Determination of Shear reinforcement

$$V_s = 103.17 \text{ kip}$$

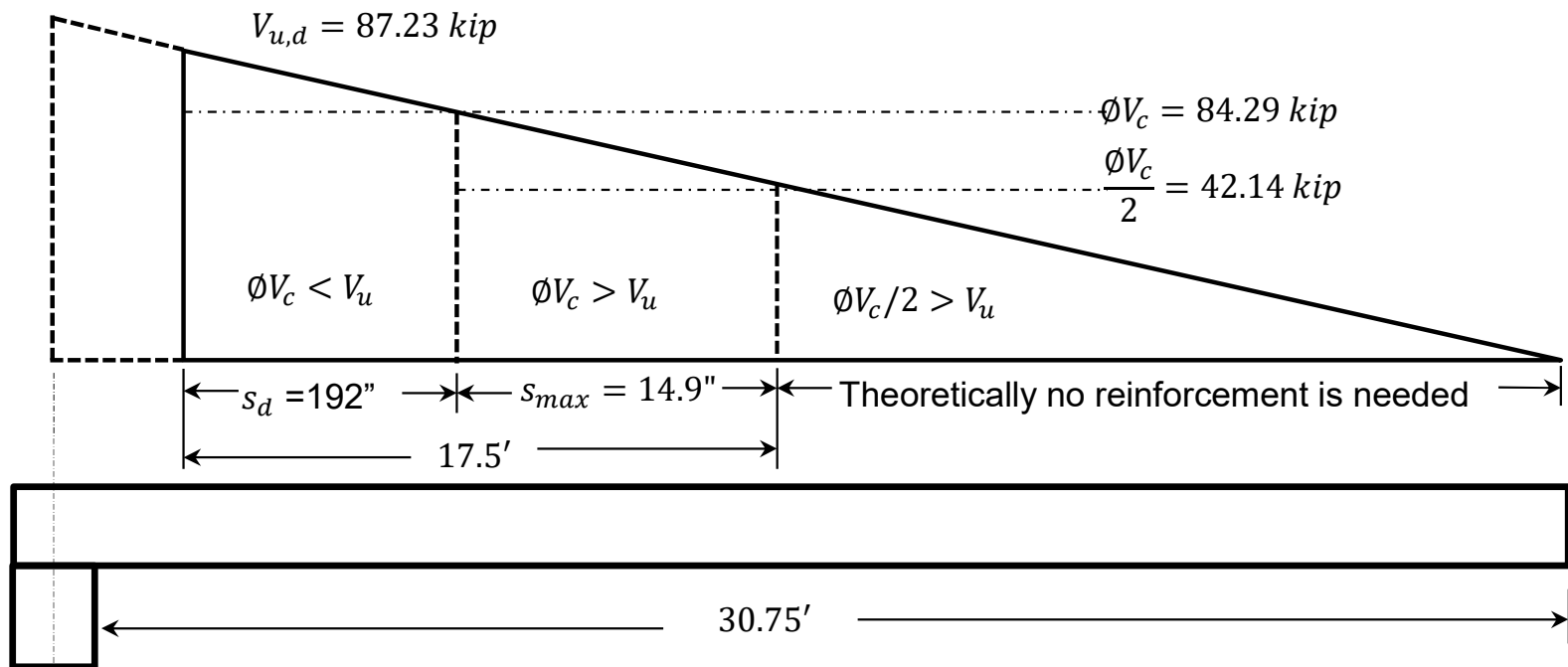

Finally provide #3 @ 12" c/c throughout.



# Design of 90' x 60' Hall

## □ Solution [option 1a]

### ❖ Beam Design

#### ➤ Step 8: Determination of Skin Reinforcement

- For relatively deep beams, some reinforcement should be placed near the vertical faces of the tension zone to control cracking in the web (ACI R9.7.2.3). This is termed as *skin reinforcement*.

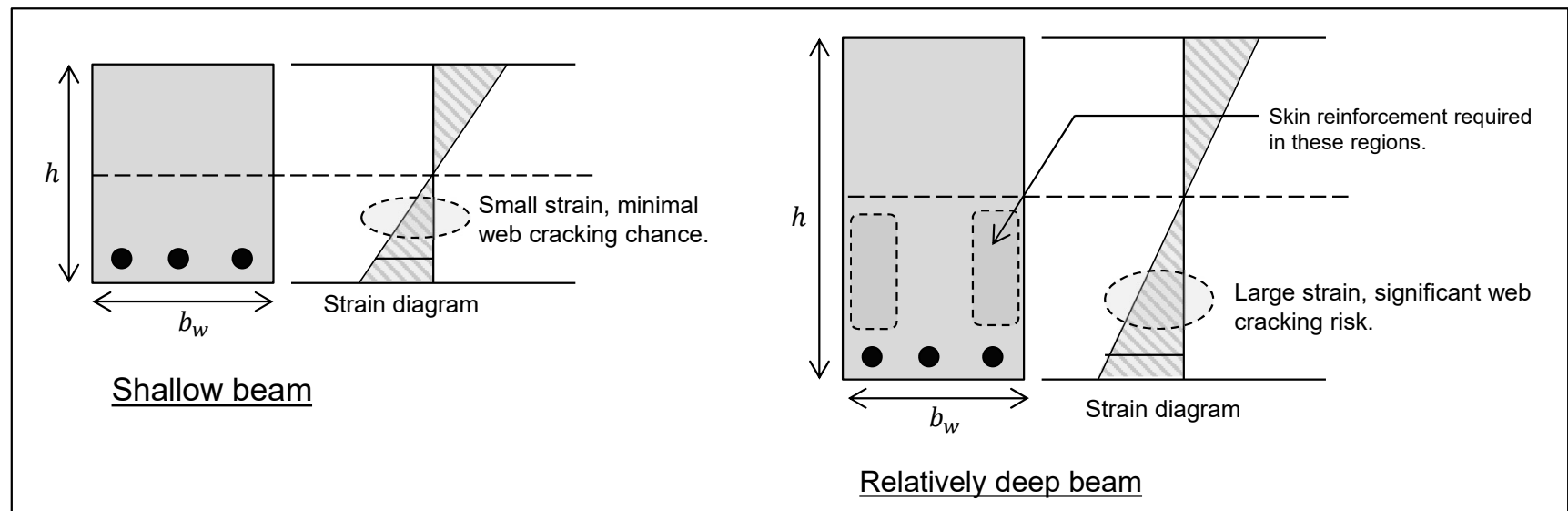





# Design of 90' x 60' Hall

## □ Solution [option 1a]

### ❖ Beam Design

#### ➤ Step 8: Determination of Skin Reinforcement

- For beams with depth exceeding 36 inches ( $h \geq 36''$ ), longitudinal skin reinforcement shall be uniformly distributed on both side faces of the beam for a distance  $h/2$  from the tension face (ACI 9.7.2.3).

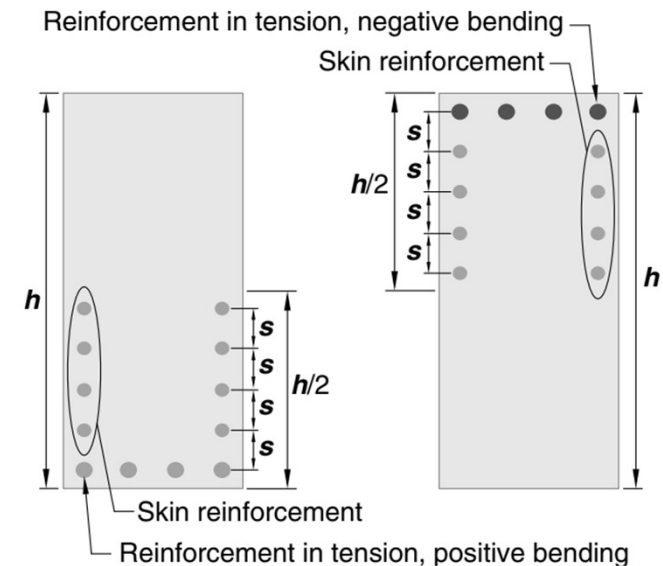

Skin Reinforcement for beams with  $h > 36''$



# Design of 90' x 60' Hall

## □ Solution [option 1a]

### ❖ Beam Design

#### ➤ Step 8: Determination of Skin Reinforcement

##### ▪ Amount of skin reinforcement

- Bar sizes No. 3 to No.5, with a minimum area of 0.1 in<sup>2</sup> per foot of depth (0.1h), are typically provided (ACI R9.7.2.3).

##### ▪ Spacing of skin reinforcement

- Spacing shall not exceed  $S_{max}$  given by

$$S_{max} = 15 \left( \frac{40,000}{f_s} \right) - 2.5C_c \text{ or } 12 \left( \frac{40,000}{f_s} \right) \text{ whichever is lesser}$$

Where;  $f_s = 2/3f_y$  and  $C_c$  is clear cover.



# Design of 90' x 60' Hall

## □ Solution [option 1a]

### ❖ Beam Design

#### ➤ Step 8: Determination of Skin Reinforcement

$$A_{skin} = 0.1h = 0.1 \times 5 = 0.5 \text{ in}^2 \quad (\text{where } h \text{ is in feet, not inches})$$

Using #3 bar with  $A_b = 0.11 \text{ in}^2$

No. of bars =  $0.5/0.11 = 4.55 \approx 5$  (for the purpose of symmetry, take 6 bars.)

- Hence, 6 - #3 bars will be provided on each face of beam. The range up to which skin reinforcement is provided is given by

$$h/2 = 60/2 = 30'' \quad (\text{from tension face})$$



# Design of 90' x 60' Hall

## □ Solution [option 1a]

### ❖ Beam Design

#### ➤ Step 8: Determination of Skin Reinforcement

- Spacing between adjacent skin rebars

$$y = 30 - \left( 1.5 + \frac{3}{8} + 1 + 1 + 1 \right) = 25.13''$$

$$n = \text{no. of bars on one face} = 3$$

Now,

$$S = \frac{n}{y} = \frac{25.13}{3} = 8.4''$$

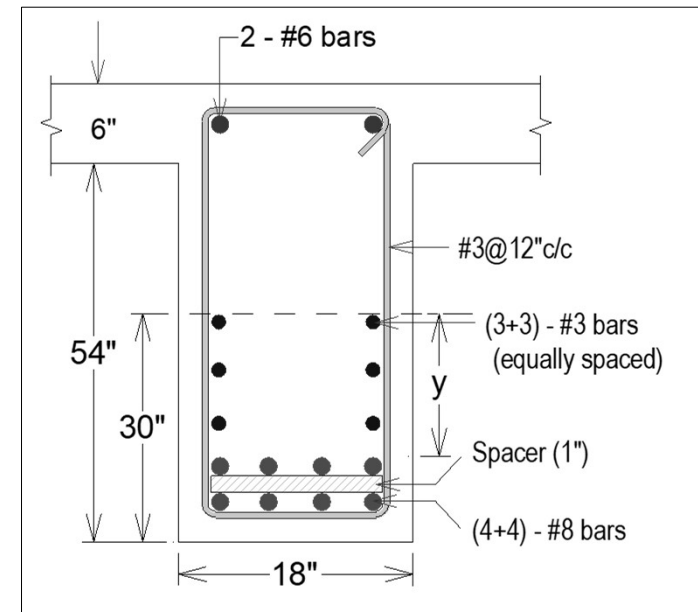



# Design of 90' x 60' Hall

## □ Solution [option 1a]

### ❖ Beam Design

#### ➤ Step 8: Determination of Skin Reinforcement

- Maximum spacing for skin reinforcement

$$S_{max} = 15 \left( \frac{40,000}{f_s} \right) - 2.5C_c \quad \text{or} \quad 12 \left( \frac{40,000}{f_s} \right) \quad \text{whichever is lesser}$$

$$15 \left[ \frac{40,000}{2/3(60,000)} \right] - 2.5(1.5) = 11.25'' \quad \text{and} \quad 12 \left[ \frac{40,000}{2/3(60,000)} \right] = 12''$$

As  $S = 8.4'' < S_{max} = 11.25''$ , therefore provided spacing is OK.



# Design of 90' x 60' Hall

## □ Solution [option 1a]

### ❖ Beam Design

### ➤ Step 9: Drafting

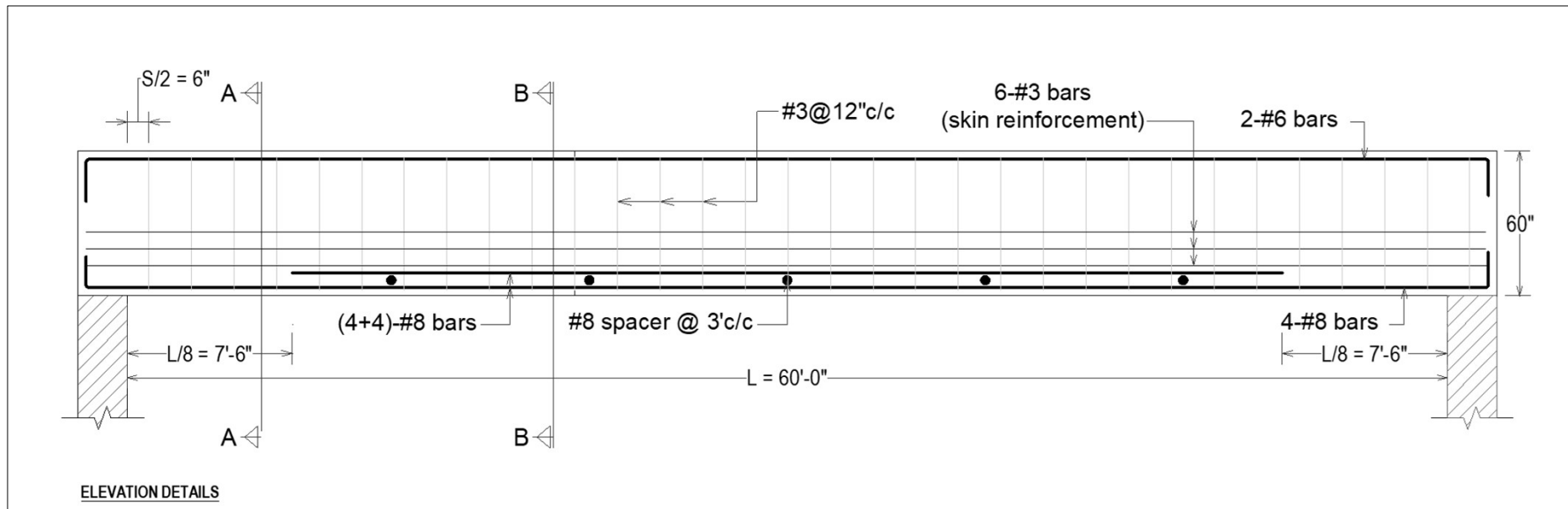



# Design of 90' x 60' Hall

## □ Solution [option 1a]

### ❖ Beam Design

### ➤ Step 9: Drafting

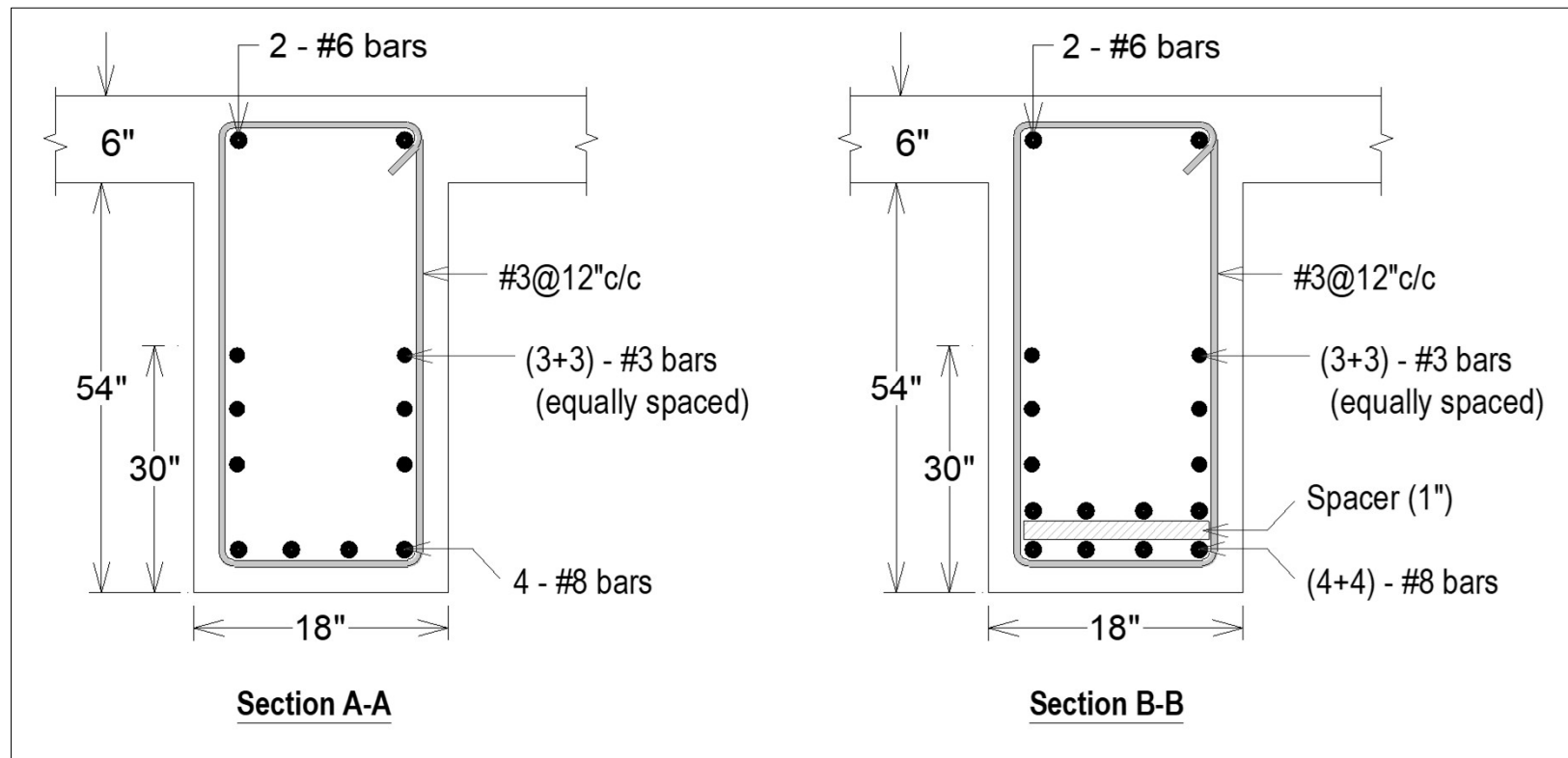



# **Design of 90' X 60' Hall**

## **Option 1b**





# Design of 90' x 60' Hall

## □ Solution [option 1b]

### ➤ Step 1: Selection of Structural Configuration

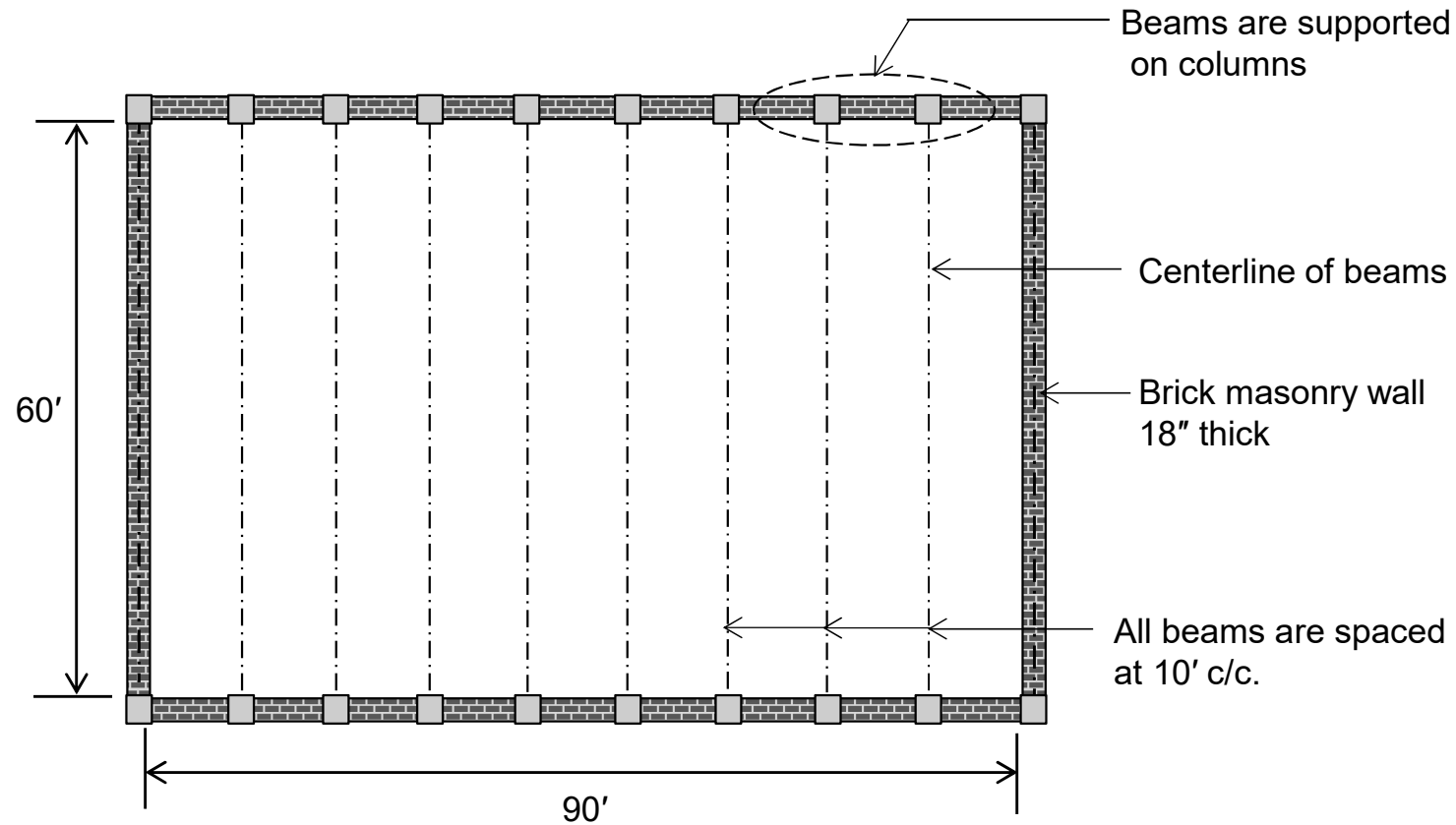



# Design of 90' x 60' Hall

## □ Solution [option 1b]

### ➤ Step 1: Selection of Structural Configuration

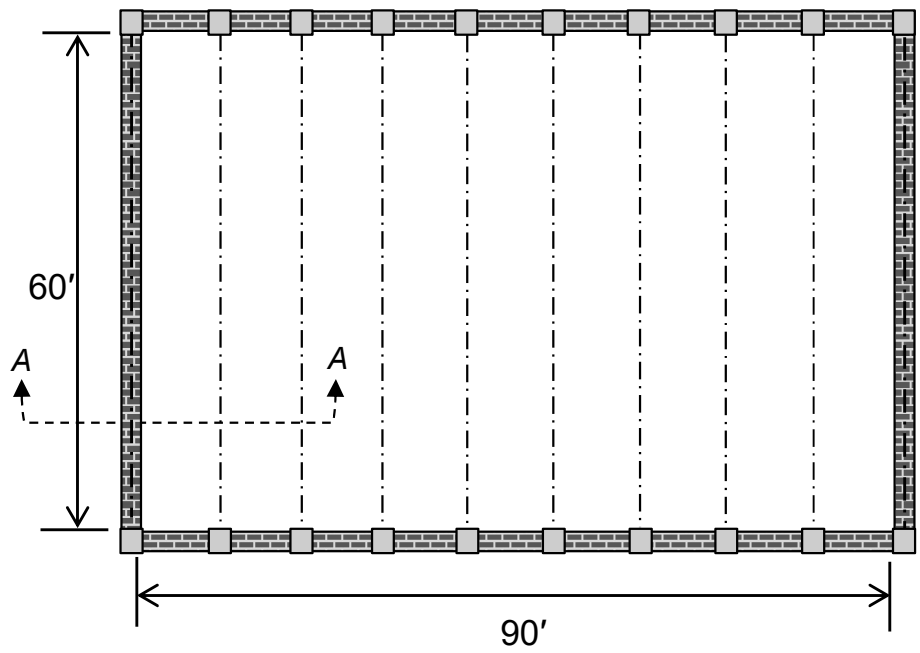

Wall width = 18 in  
 Assumed beam width = 18 in

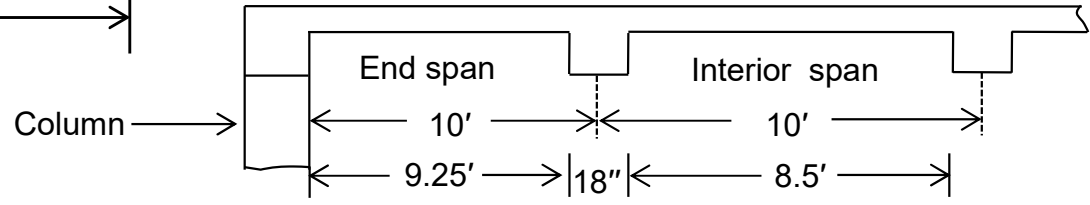
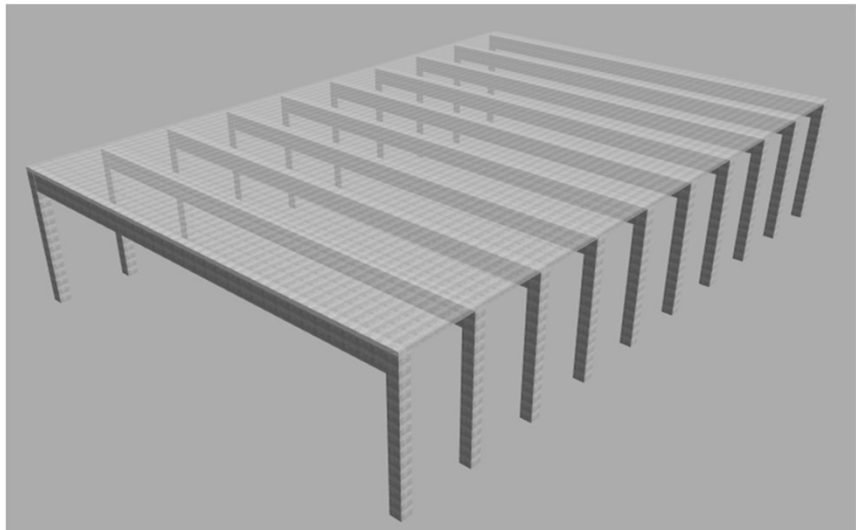

Section A-A



# Design of 90' x 60' Hall

## □ Solution [option 1b]

### ❖ Slab Design

- Analysis





# Design of 90' x 60' Hall

## □ Solution [option 1b]

### ❖ Slab Design

- Moment capacity provided by minimum reinforcement  $\phi M_n = 33.95$  in.kip (calculated in option 1a) is greater than all the moments shown on previous slide, therefore Minimum reinforcement governs.
- Hence Provide;
  - Main reinforcement : #3 @ 9" c/c (both positive & negative)
  - Shrinkage reinforcement : #3 @ 9" c/c
  - Supporting bars : #3 @ 18" c/c



# Design of 90' x 60' Hall

## □ Solution [option 1b]

### ❖ Slab Design

- Drafting

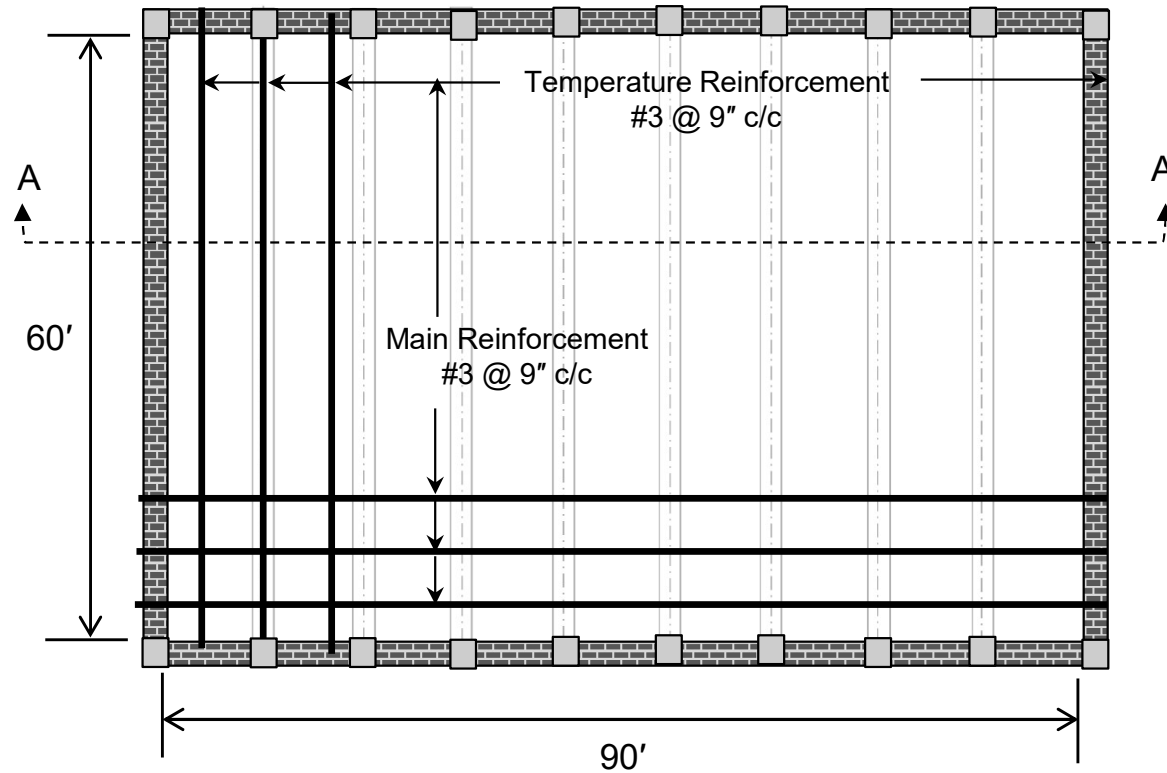



# Design of 90' x 60' Hall

## □ Solution [option 1b]

### ❖ Slab Design

- Drafting

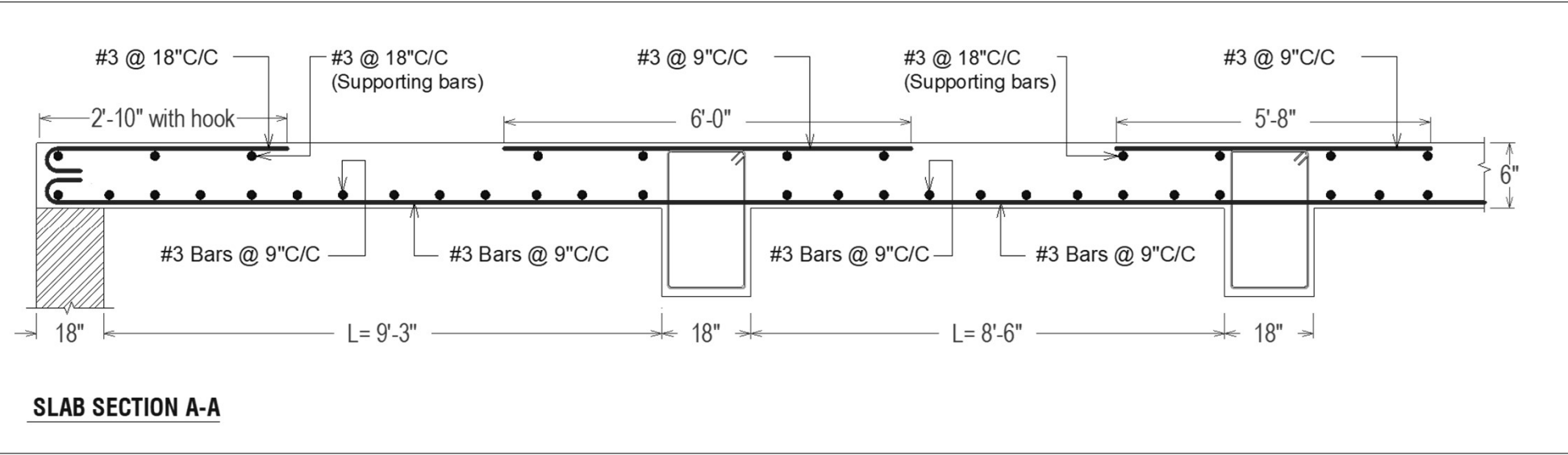



# Design of 90' x 60' Hall

## □ Solution [option 1b]

### ❖ Frame Analysis

- A 2D frame can be detached from a 3D system in the following manner:

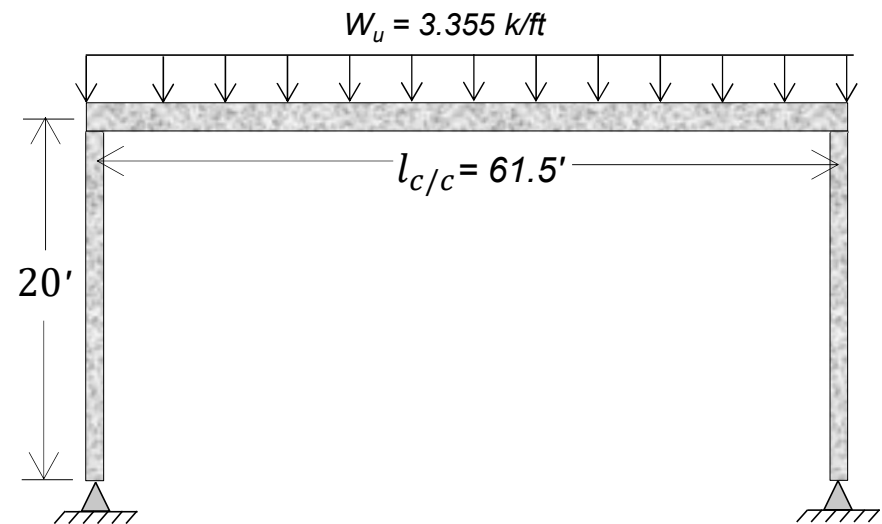
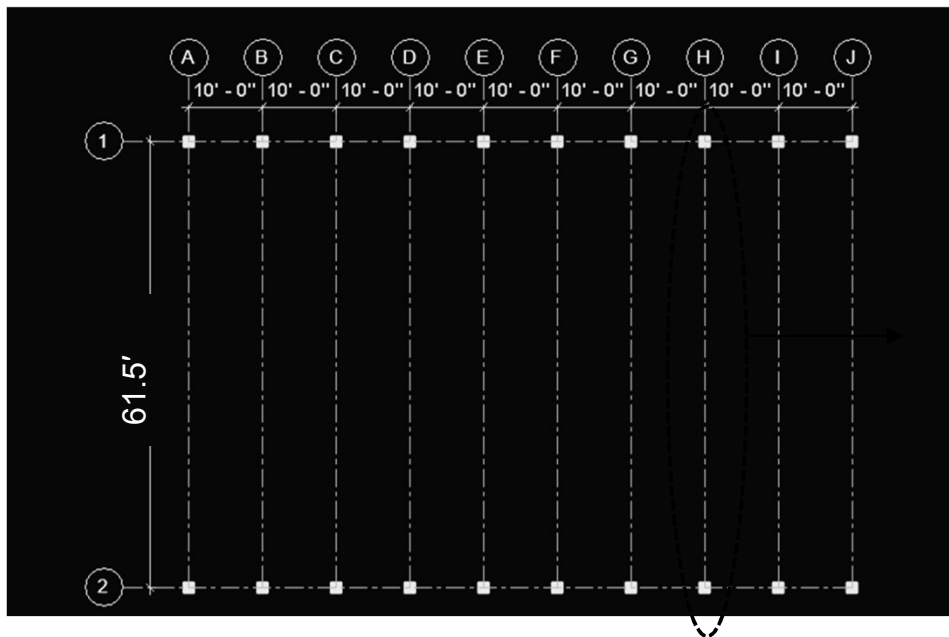



# Design of 90' x 60' Hall

## □ Solution [option 1b]

### ❖ Frame Analysis

- Numerous methods are available for frame analysis. here, we will use the Simplified Flexibility Method.

$$P_u = \frac{3.355 \times 61.5}{2} = \mathbf{103.17 \text{ kip}}$$

$$K_r = \frac{(18 \times 60^3)/12}{(18 \times 18^3)/12} = 37.04$$

$$M_{u,neg} = \frac{3.355(61.5)^3 \times 12}{12(61.5) + 8(20)(37.04)} = \mathbf{1405.20 \text{ in. kip}}$$

$$M_{u,pos} = \frac{3.355(61.5)^2 \times 12}{8} - 1405.20 = \mathbf{17628.97 \text{ in. kip}}$$

$$V_u = \frac{1405.20}{20 \times 12} = \mathbf{5.86 \text{ kip}}$$

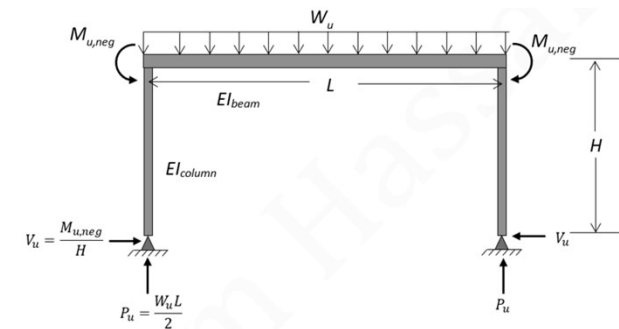

### Simplified Flexibility Method:

A simplified flexibility method, used for analyzing a single bay, non-sway, symmetrical pin-supported frame under uniformly distributed load.

$$M_{u,neg} = \frac{W_u L^3}{12L + 8HK_r} ; K_r = \frac{EI_b}{EI_c}$$

$$M_{u,pos} = \frac{W_u L^2}{8} - M_{u,neg}$$





# Design of 90' x 60' Hall

## □ Solution [option 1b]

### ❖ Frame Analysis

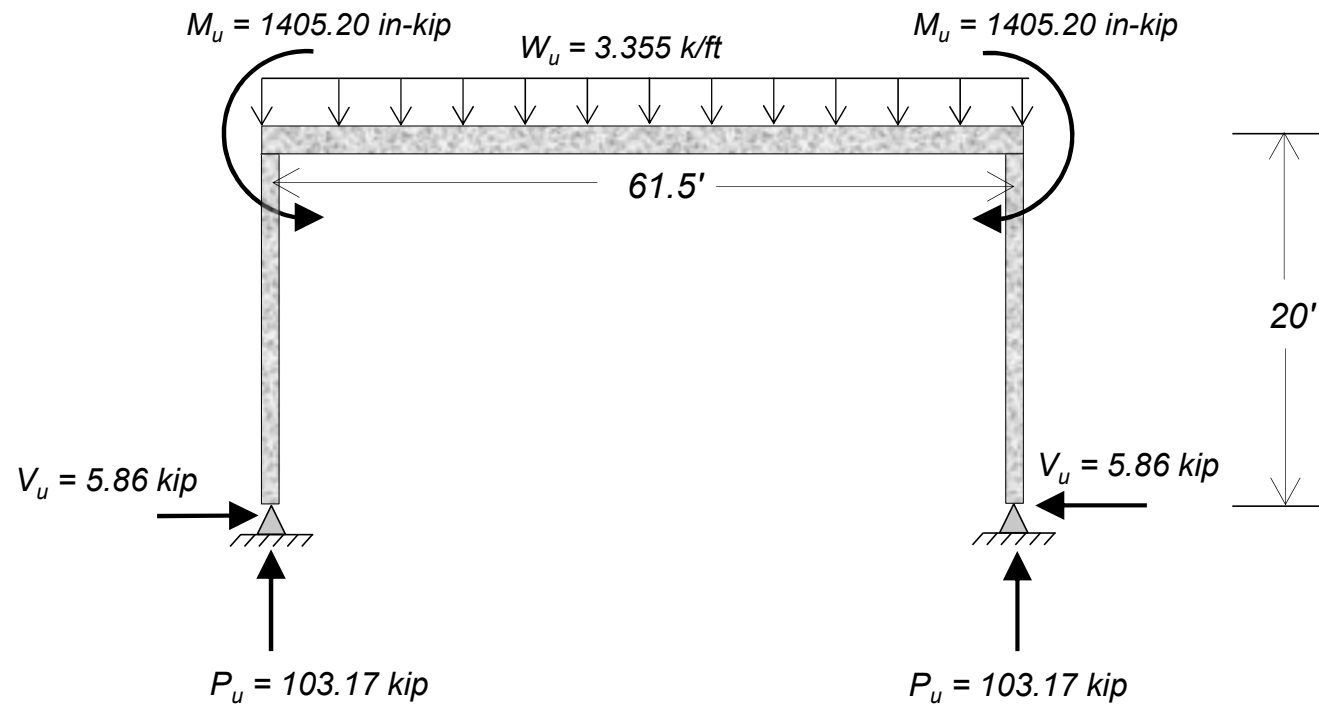



# Design of 90' x 60' Hall

## □ Solution [option 1b]

### ❖ Frame Analysis

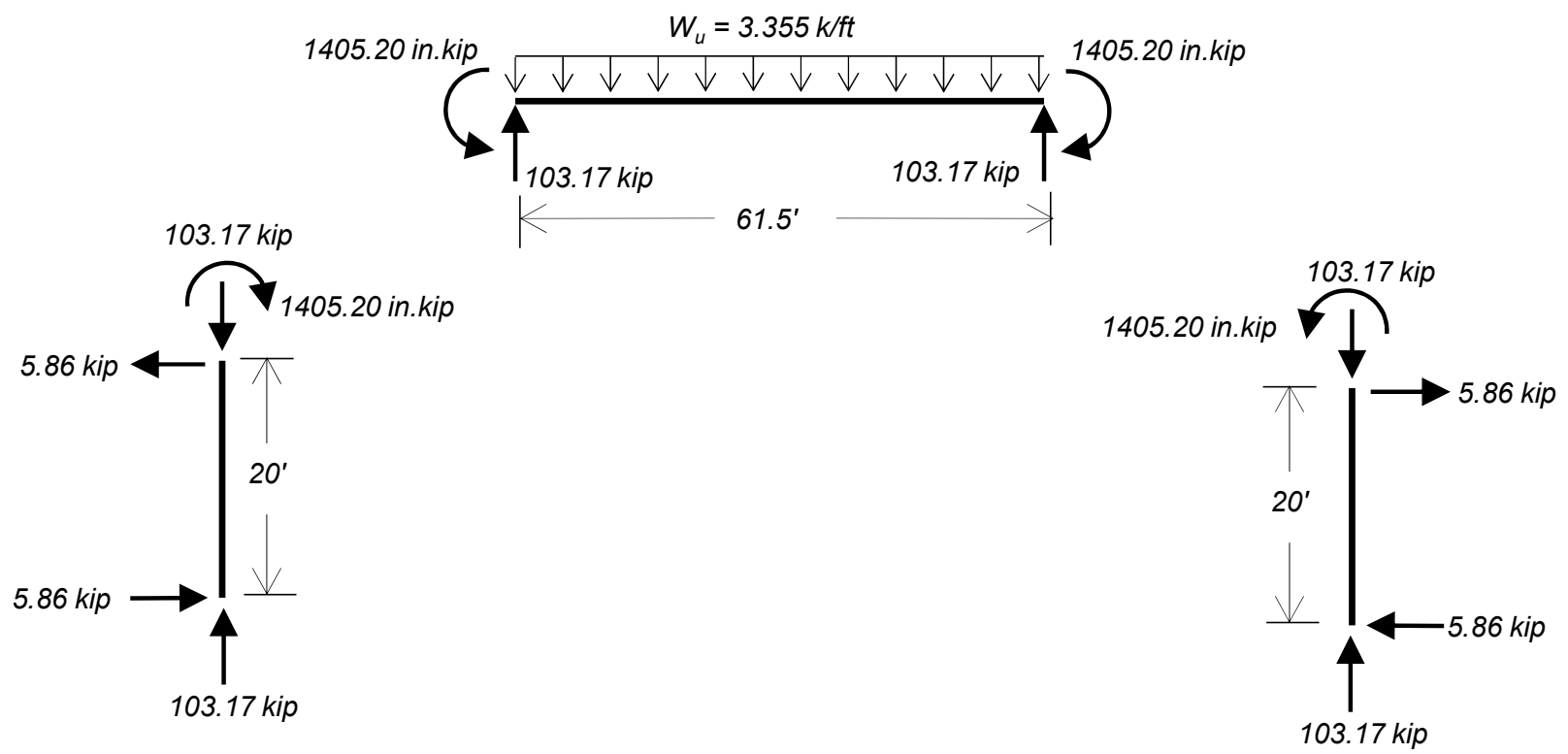



# Design of 90' x 60' Hall

## □ Solution [option 1b]

### ❖ Frame Analysis

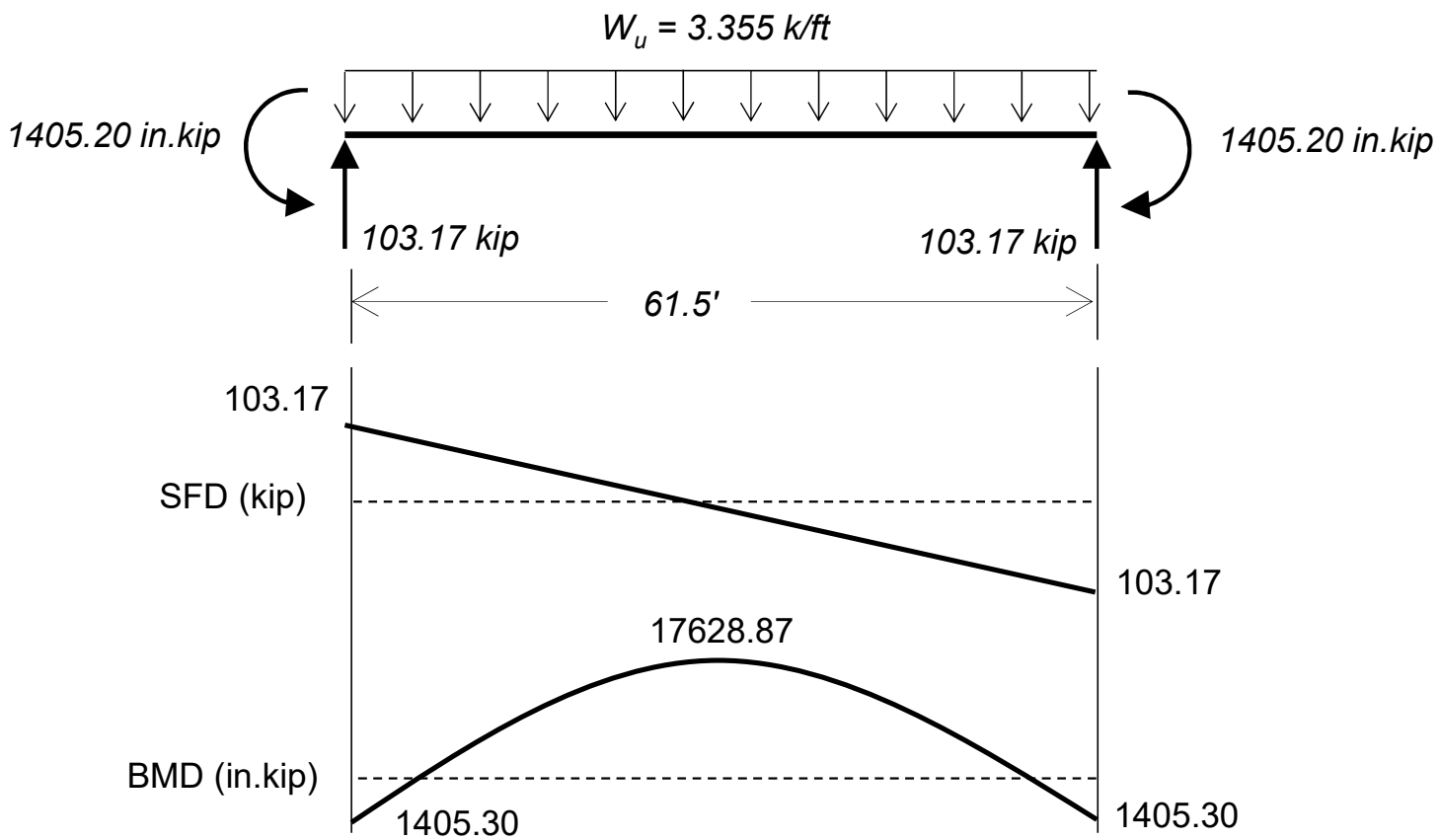



# Design of 90' x 60' Hall

## □ Solution [option 1b]

### ❖ Frame Analysis

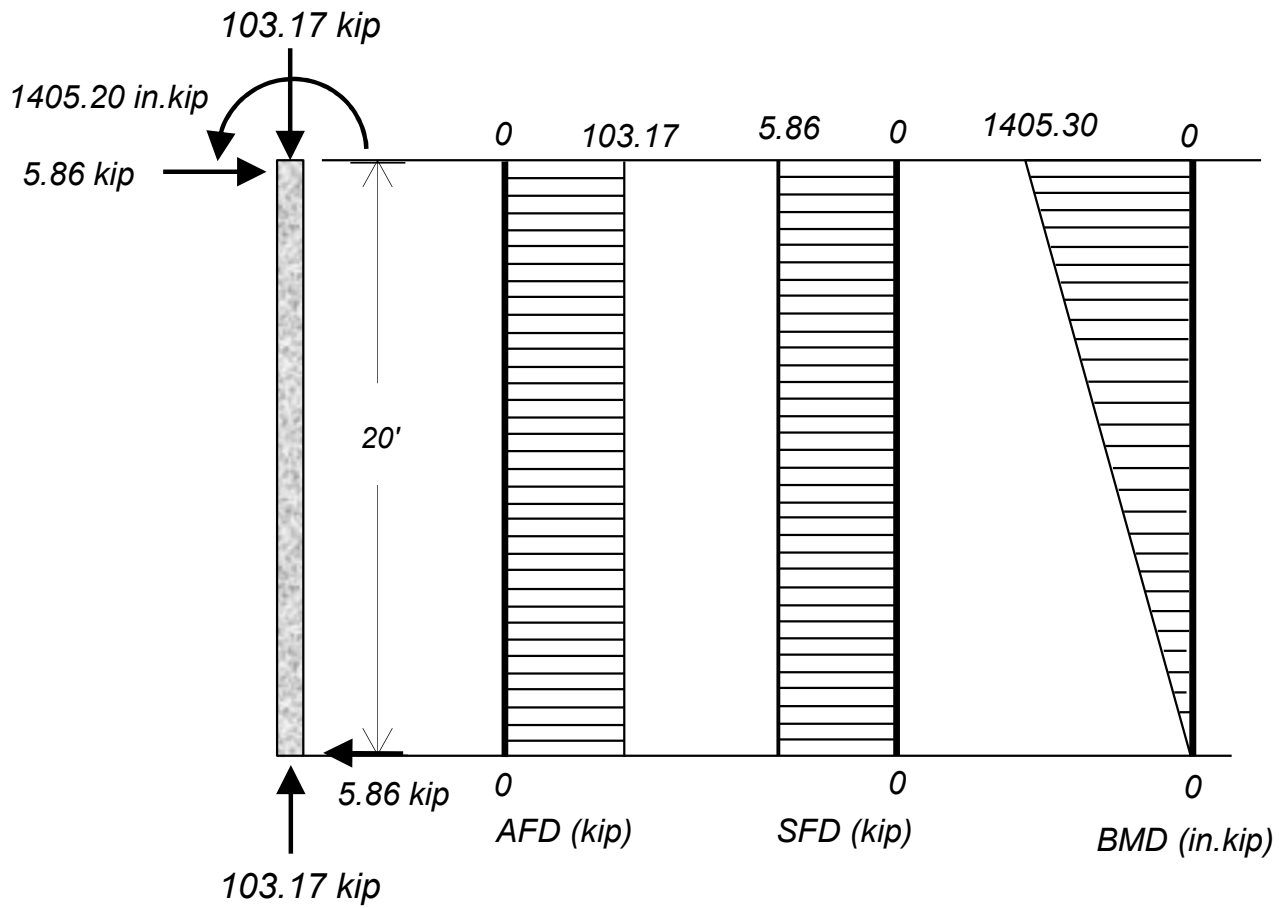



# Design of 90' x 60' Hall

## □ Solution [option 1b]

### ❖ Frame Analysis

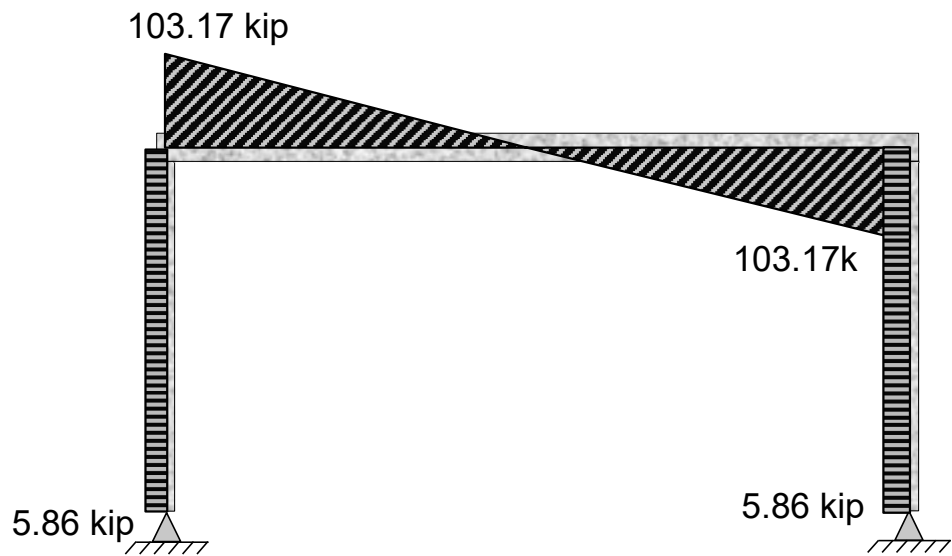

Combined Shear Force Diagram

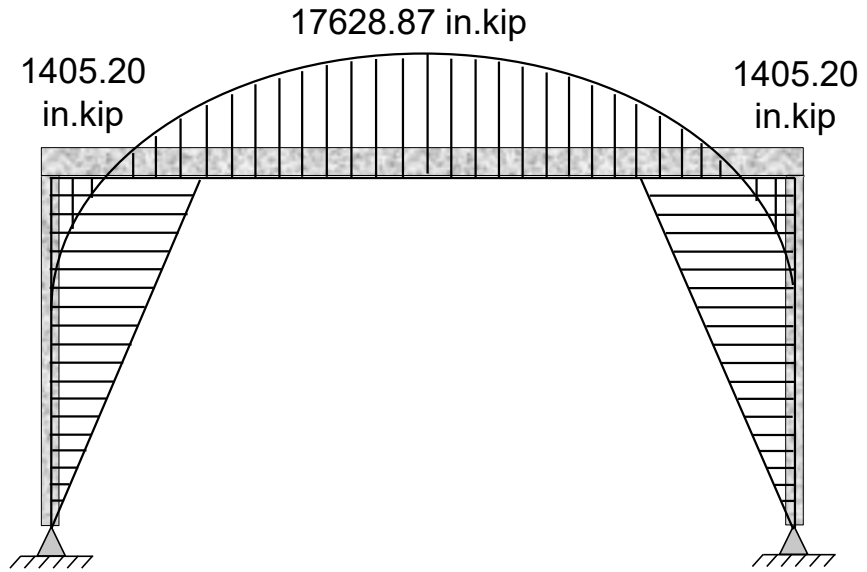

Combined Bending Moment Diagram



# Design of 90' x 60' Hall

## □ Solution [option 1b]

### ❖ Beam Design

#### ■ Flexural Design

- The flexural design summary is tabulated below.

Moment ( <i>in. kip</i> )	Required $A_s$ ( $in^2$ )	$A_{min}$ ( $in^2$ )	$A_{max}$ ( $in^2$ )	Detailing
$M_u(+)$ = 17628.97	5.79	5.13	13.80	(4+4)-#8
$M_u(-)$ = 1405.20	0.46	---	13.80	2-#6



# Design of 90' x 60' Hall

## □ Solution [option 1b]

### ❖ Beam Design

#### ■ Shear Design

- The shear design for the beam will remain the same as before.

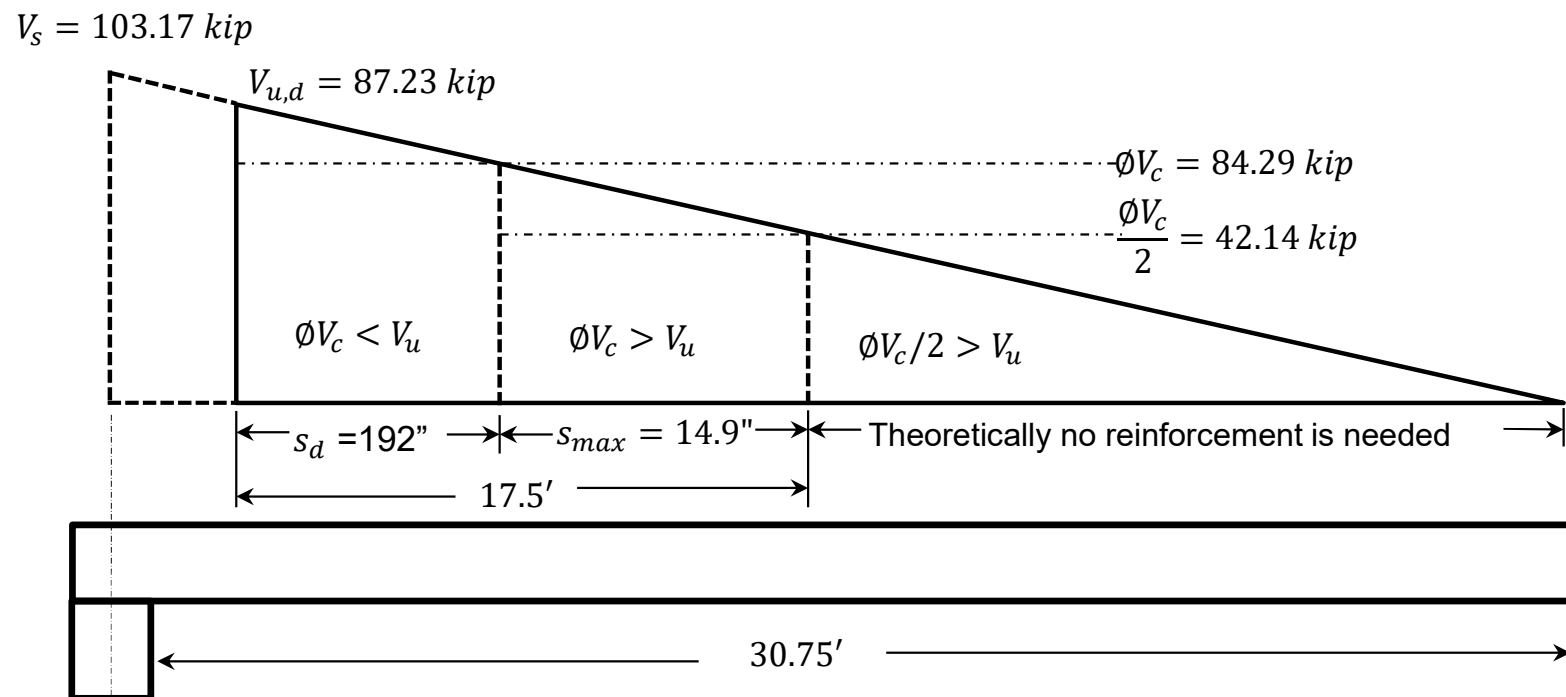



# Design of 90' x 60' Hall

## □ Solution [option 1b]

### ❖ Beam Design

#### ■ Drafting

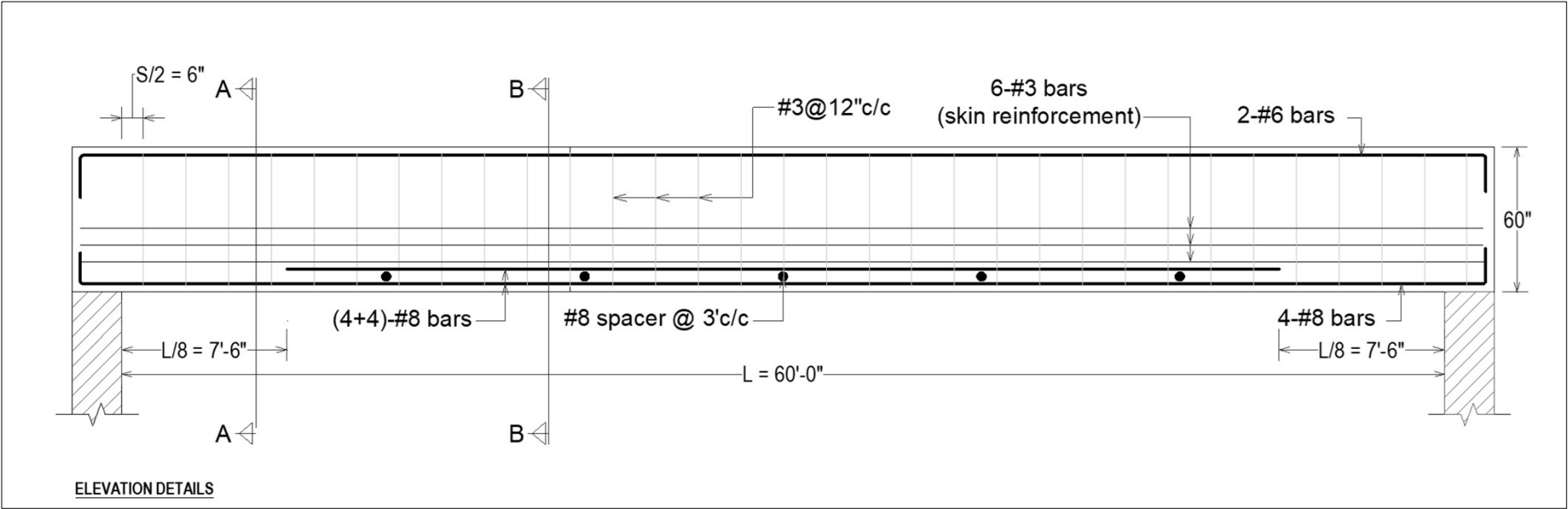





# Design of 90' x 60' Hall

## □ Solution [option 1b]

### ❖ Beam Design

#### ■ Drafting

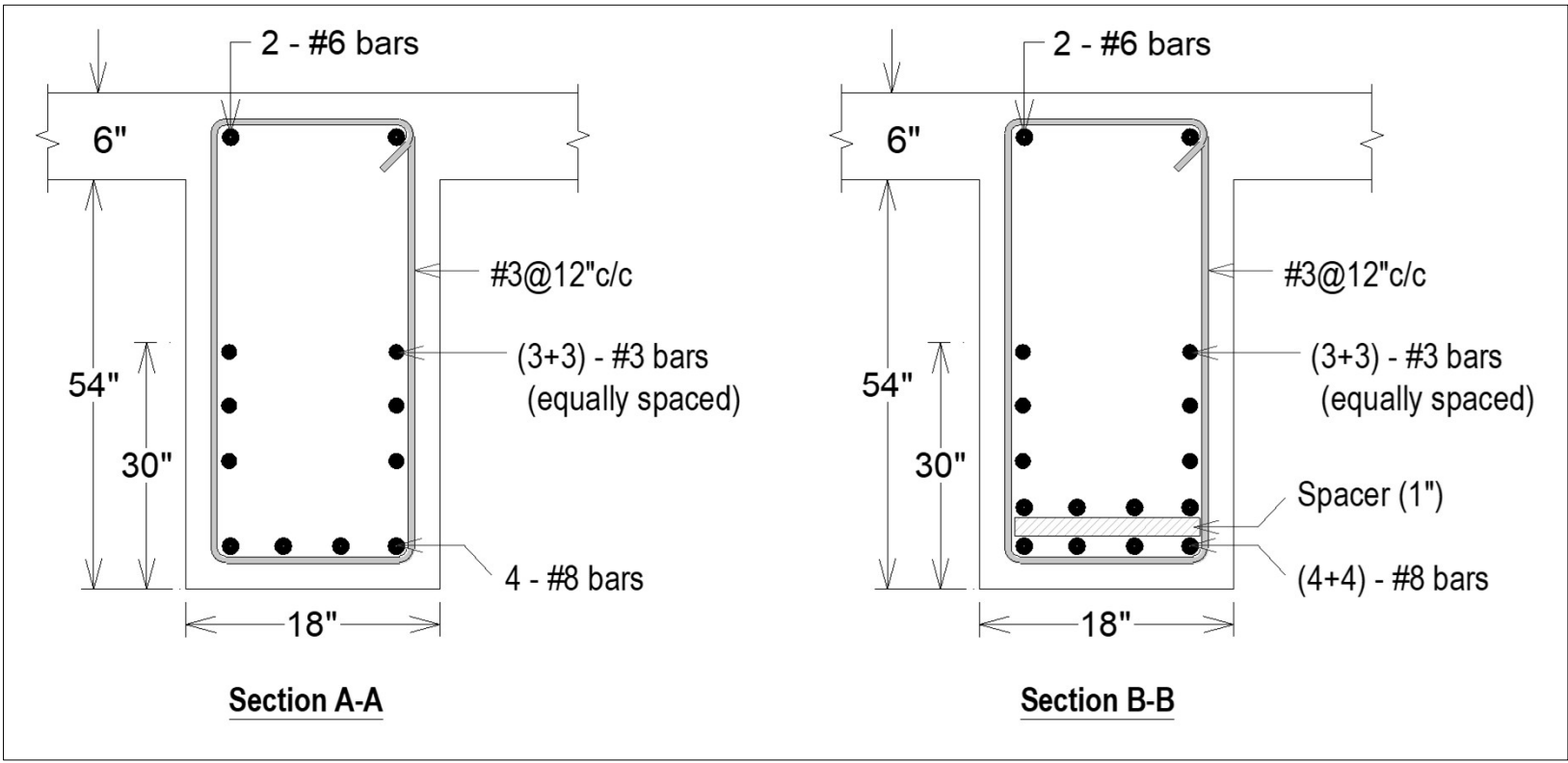



# Design of 90' x 60' Hall

## □ Solution [option 1b]

### ❖ Column Design

- Longitudinal Reinforcement of column can be determined using Design Aids as follows:

1. Select appropriate dimensions:

$$b = h = 18''$$

2. Calculate ratio  $\gamma$

Assuming  $d' = 2.5in$

$$\gamma = \frac{18 - 2(2.5)}{18} = 0.72 \approx 0.70$$

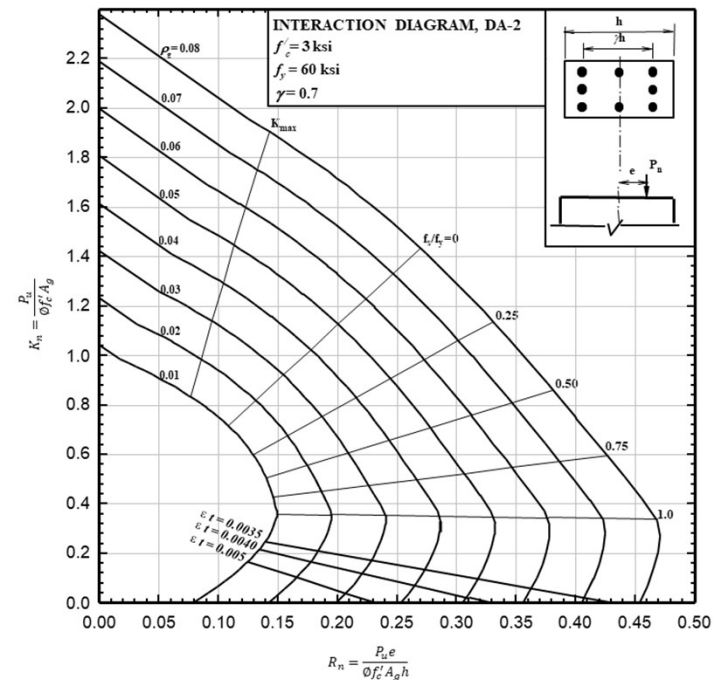



# Design of 90' x 60' Hall

## □ Solution [option 1b]

### ❖ Column Design

3. Calculate  $K_n$  and  $R_n$  factor

$$K_n = \frac{P_u}{\phi f'_c b h} = \frac{103.17}{0.65 \times 3 \times 18 \times 18}$$

$$K_n = 0.16$$

$$R_n = \frac{M_u}{\phi f'_c b h^2} = \frac{1407}{0.65 \times 3 \times 18 \times 18^2}$$

$$R_n = 0.12$$

For  $\gamma = 0.70$ ,  $f'_c = 3 \text{ ksi}$  and  $f_y = 60 \text{ ksi}$ , The relevant Design Aid is DA – 2 (from Appendix)



# Design of 90' x 60' Hall

## □ Solution [option 1b]

### ❖ Column Design

4. Read  $\rho_g$  from the graph

$$\rho_g = 0.01$$

5. Calculate Area of steel

$$A_{st} = 0.01 \times 18^2 = 3.24 \text{ in}^2$$

Using #6 bar

$$\text{No. of bars} = \frac{3.24}{0.44} \approx 8$$

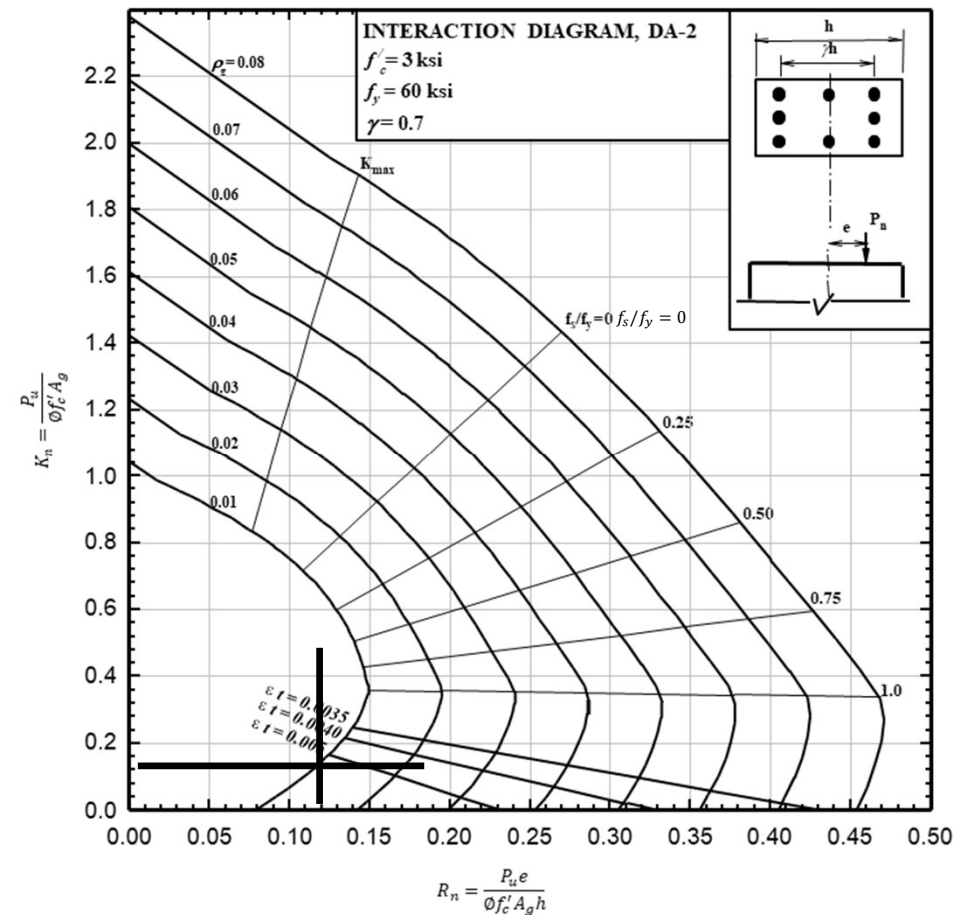



# Design of 90' x 60' Hall

## □ Solution [option 1b]

### ❖ Column Design

#### ▪ Spacing of Ties

- Using #3 tie bars for #6 main bars, spacing for Tie bars according to ACI 25.7.2.1 is minimum of
  - a.  $16 \times \text{dia. of main bar} = 16 \times 6/8 = 12'' \text{ c/c}$
  - b.  $48 \times \text{dia. of tie bar} = 48 \times (3/8) = 18'' \text{ c/c}$
  - c. Least column dimension =  $18'' \text{ c/c}$
- Finally use #3, tie bars @  $9'' \text{ c/c}$



# Design of 90' x 60' Hall

## □ Solution [option 1b]

### ❖ Column Design (Drafting)

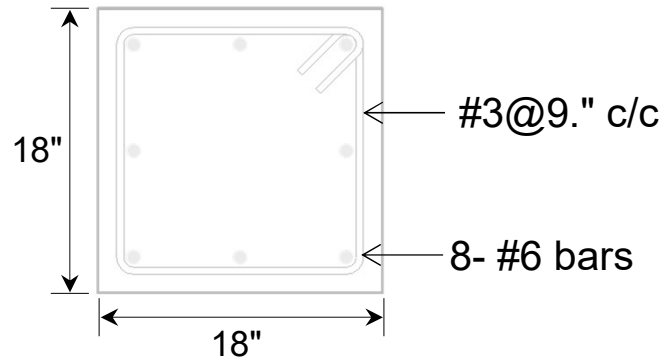

**Section A-A**

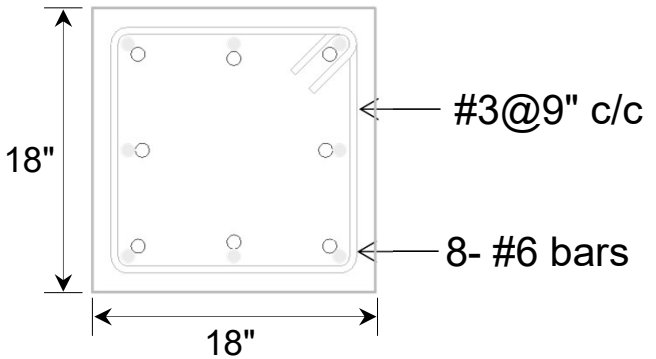

**Section B-B**

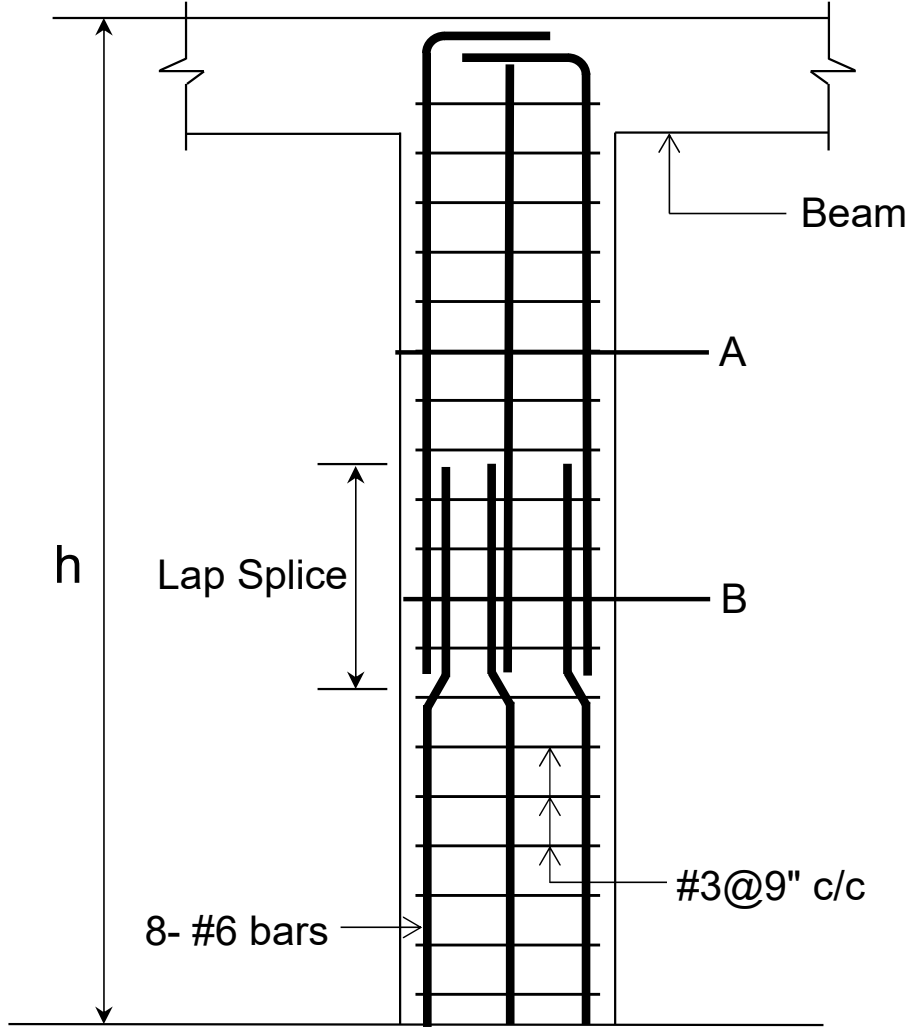



# Design of 90' x 60' Hall

## □ Solution [option 1b]

### ❖ Footing Design

#### ▪ Given Data

- Column size = 18" × 18"
- $f_c' = 3$  ksi
- $f_y = 60$  ksi
- $q_a = 2.204$  ksf
- Reaction at the support should be used in design of footing.
  - Factored load on column (reaction at support) = 103.17 kips
  - Service load on column (reaction at support) = 81.87 kips



# Design of 90' x 60' Hall

## □ Solution [option 1b]

### ➤ Step 1: Selection of sizes

- Thickness

Assume thickness of footing "h" as 15 in. Taking size of bar as #4;

$$d_{\text{avg}} = h - \bar{y} = h - (C_c + d_b)$$

putting  $C_c = 3''$  and  $d_b = 4/8''$

$$d_{\text{avg}} = 15 - (3 + 4/8) = 11.5''$$

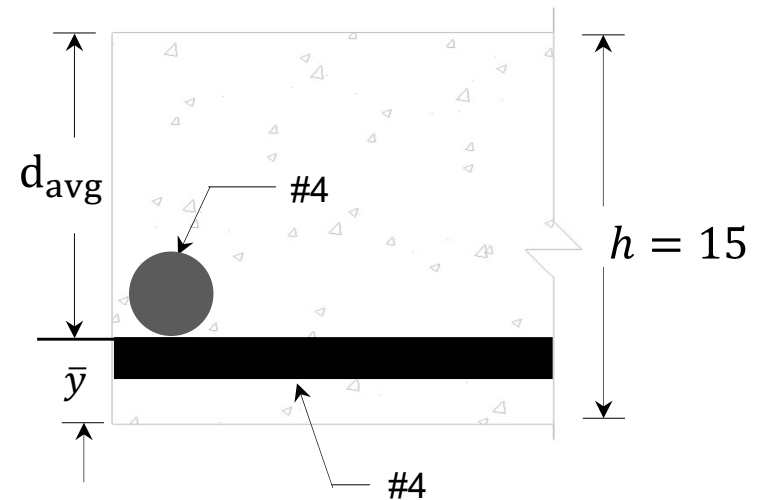





# Design of 90' x 60' Hall

## □ Solution [option 1b]

### ➤ Step 1: Selection of sizes

- Required bearing area

$$A_{req} = \frac{\text{service load}}{q_e}$$

$$q_e = q_a - \gamma_{fill}(Z - h) - \gamma_c(h)$$

$$q_e = 2.204 - 0.1(5 - 1.25) - 0.15(1.25) = 1.63 \text{ ksf}$$

$$A_{req} = \frac{81.87}{1.63} = 50.23 \text{ ft}^2$$

for square footing;

$$B = \sqrt{50.23} = 7.09 \text{ ft. Take } B = 7'$$

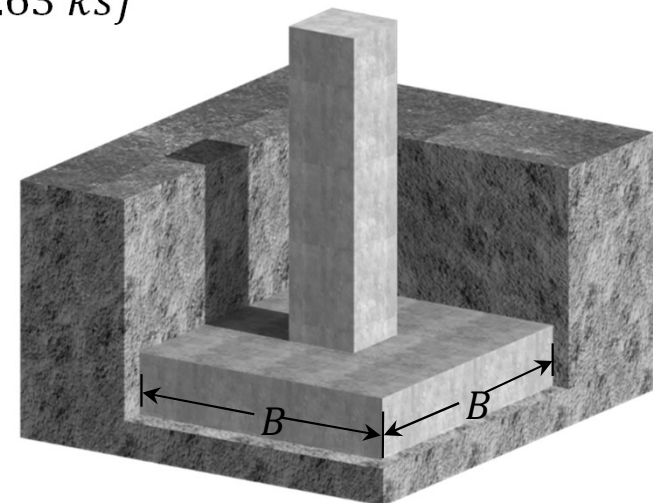
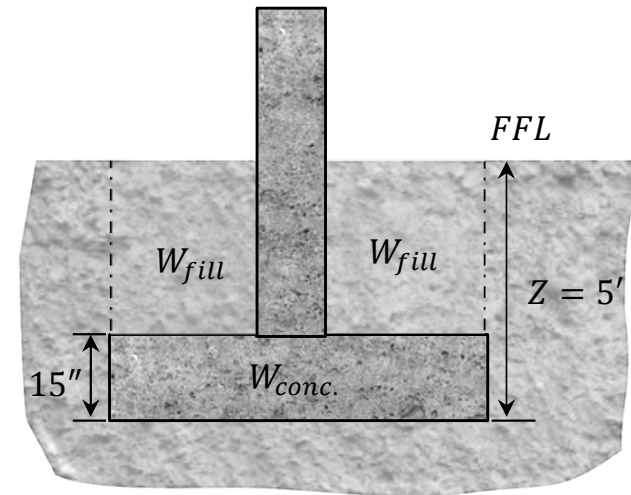



# Design of 90' x 60' Hall

## □ Solution [option 1b]

### ➤ Step 2: Calculation of loads (bearing pressure)

$$q_u = \frac{\text{Factored load}}{A_{pvd}}$$

By substituting values;

$$q_u = \frac{103.17}{7 \times 7}$$

$$q_u = 2.11 \text{ksf}$$

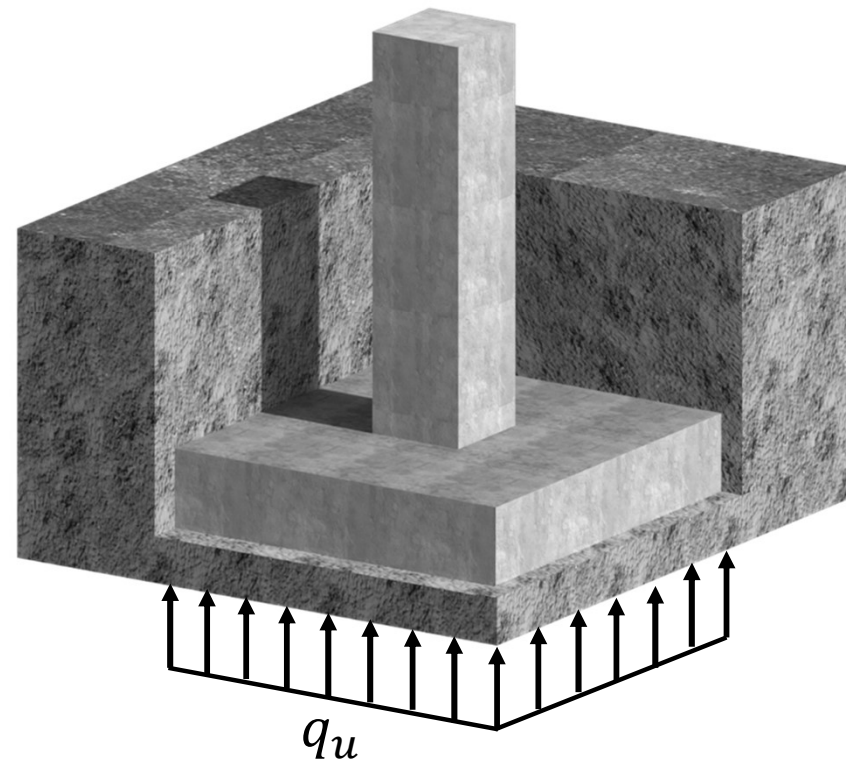



# Design of 90' x 60' Hall

## □ Solution [option 1b]

### ➤ Step 3: Analysis

- Two-way shear (punching shear)

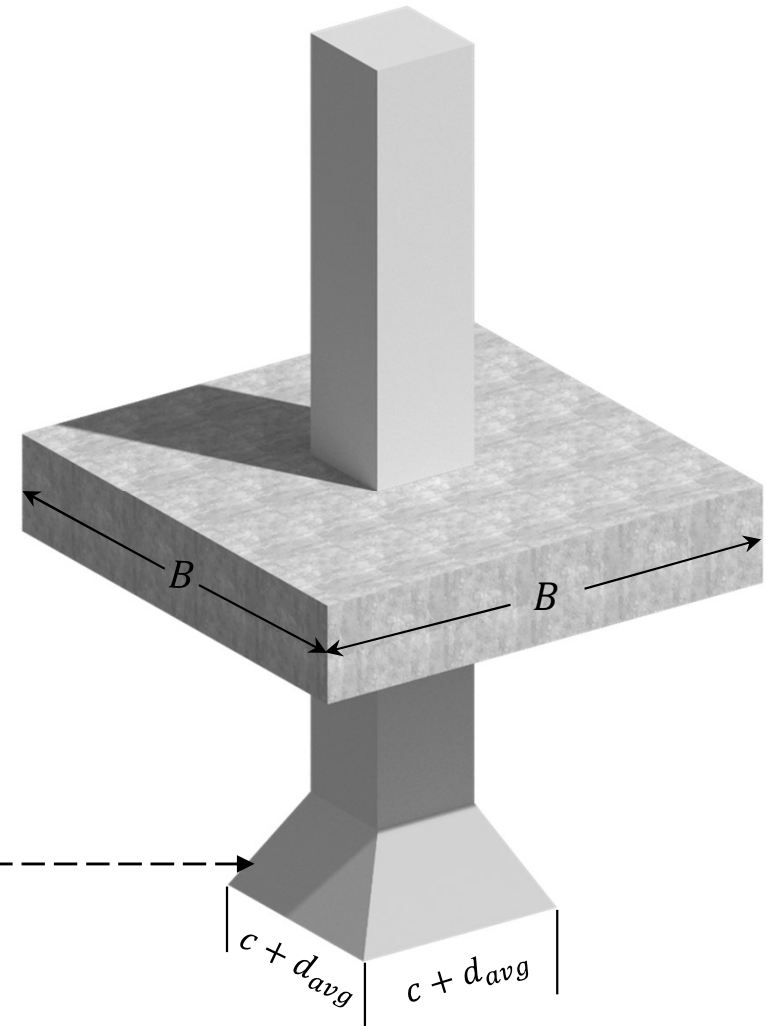
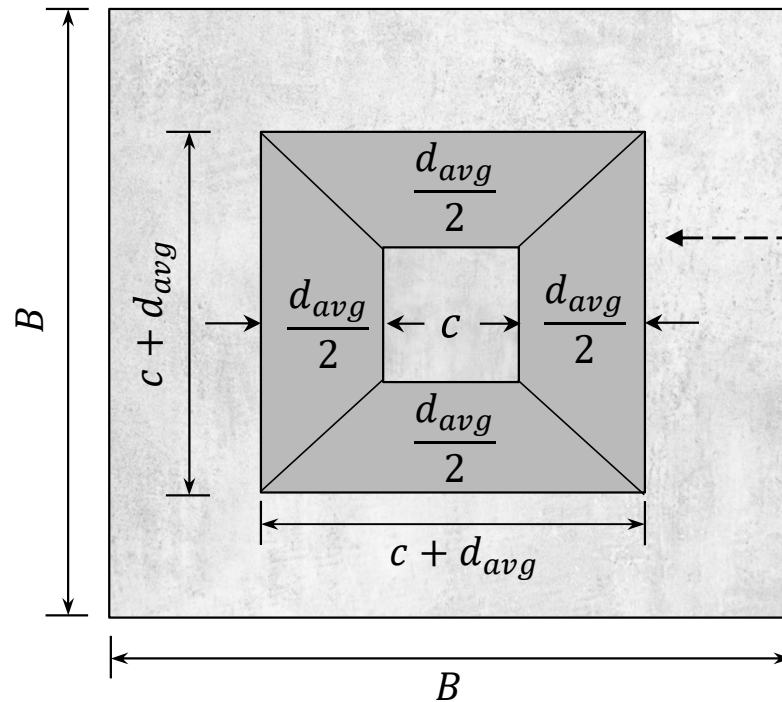



# Design of 90' x 60' Hall

## □ Solution [option 1b]

### ➤ Step 3: Analysis

- Two-way shear (punching shear)

$$V_{up} = q_u \left[ B^2 - (c + d_{avg})^2 \right]$$

On putting values

$$V_{up} = 2.11 [7^2 - (1.5 + 11.5/12)^2]$$

$$V_{up} = 90.64 \text{ kips}$$

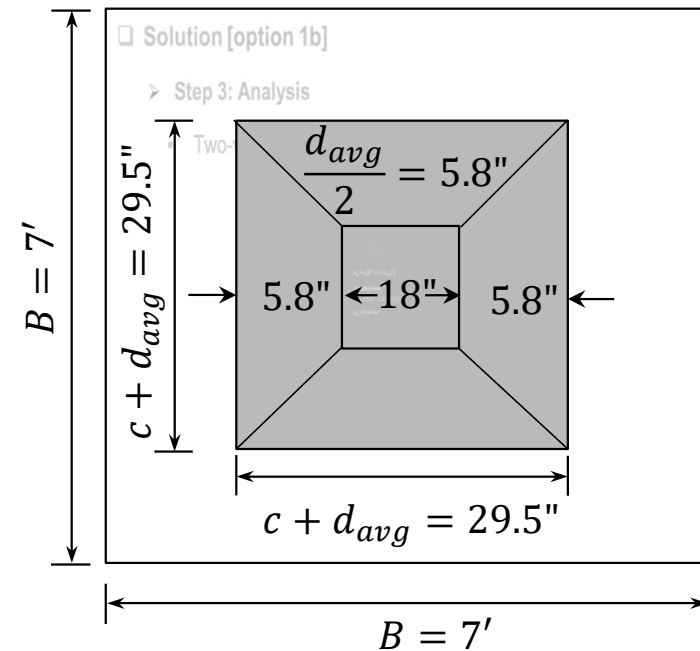



# Design of 90' x 60' Hall

## □ Solution [option 1b]

### ➤ Step 3: Analysis

- Bending moment

$$M_u = \frac{q_u B k^2}{2}$$

Here;

$$k = \frac{B - c}{2} = \frac{7 - 1.5}{2} = 2.75'$$

$$M_u = \frac{2.11(7)(2.75)^2}{2}$$

$$M_u = 55.849 \text{ ft. kip or } 670.19 \text{ in. kip}$$

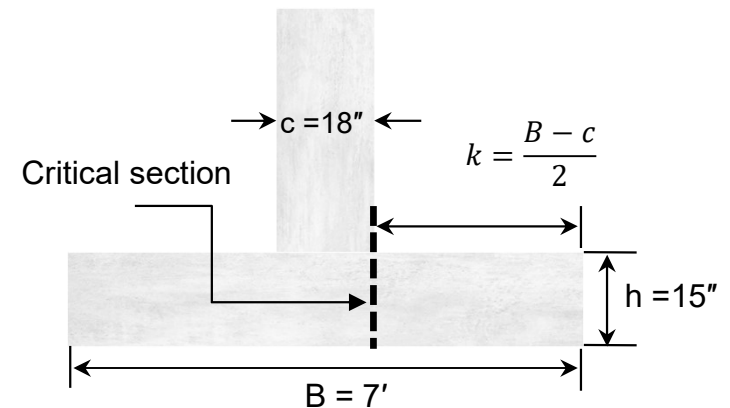
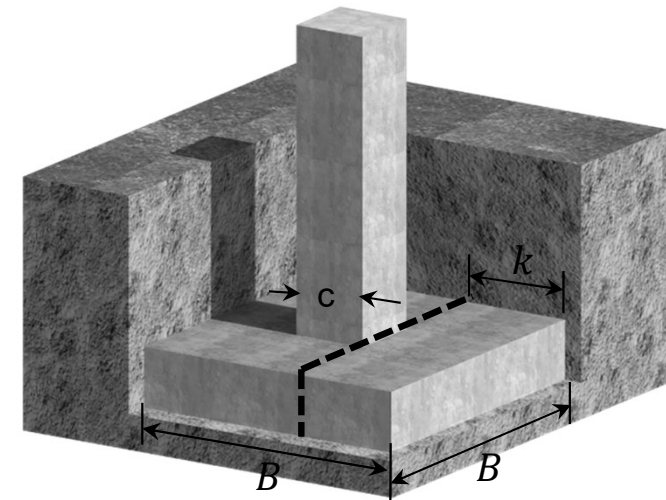



# Design of 90' x 60' Hall

## □ Solution [option 1b]

### ➤ Step 4: Applying Shear Check

$$\phi V_{cp} = 4\phi\sqrt{f_c'}b_o d_{avg}$$

$$b_o = 4(c + d_{avg})$$

$$b_o = 4(18 + 11.5) = 118''$$

Now,

$$\phi V_{cp} = 4(0.75)\sqrt{3000}(118)(11.5)/1000$$

$$\phi V_{cp} = 222.98 \text{ kip}$$

$$\phi V_{cp} = 222.98 \text{ kip} > V_{u,p} = 90.64 \text{ kip} \rightarrow \text{OK!}$$

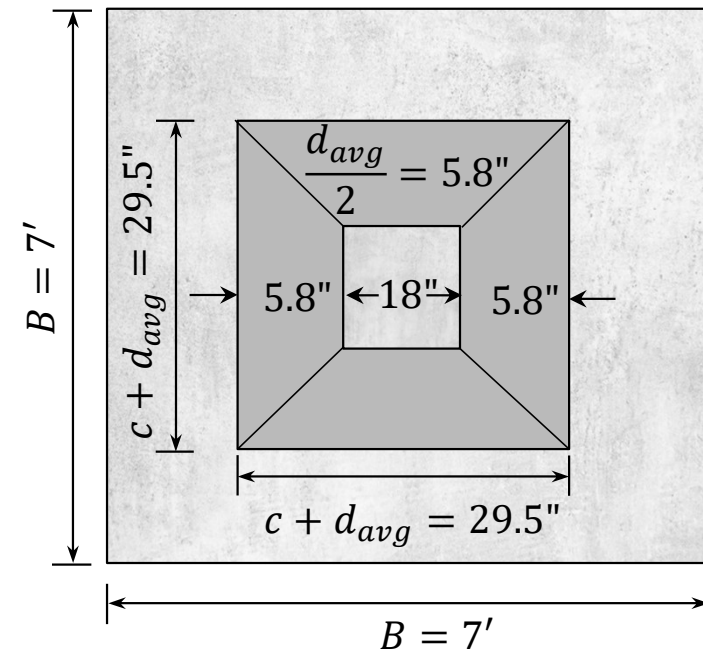



# Design of 90' x 60' Hall

## □ Solution [option 1b]

### ➤ Step 5: Determination of Flexural Reinforcement

$$a = 11.5 - \sqrt{11.5^2 - \frac{2.614(670.19)}{3(7 \times 12)}} = 0.31''$$

$$A_s = \frac{670.19}{0.9 \times 60 \left(11.5 - \frac{0.31}{2}\right)} = 1.09 \text{ in}^2$$

### ➤ Step 6: Check for Minimum Flexural Reinforcement

$$A_{s,min} = 0.0018Bh = 0.0018 \times (7 \times 12) \times 15 = 2.27 \text{ in}^2$$

$$A_s = 1.09 < A_{s,min} = 2.27 \rightarrow A_{s,min} \text{ governs!}$$



# Design of 90' x 60' Hall

## □ Solution [option 1b]

### ➤ Step 7: Detailing of Reinforcement

Using #4 bar with  $A_b = 0.20 \text{ in}^2$

$$n = \frac{2.27}{0.20} = 11.4 \approx 12 \text{ or}$$

$$S = \frac{B - 2C_c}{n - 1} = \frac{6.5 \times 12}{11} = 7'' \text{ c/c}$$

Check for maximum bar spacing

$$s_{max} = \text{Least of } 3h = 3 \times 15 = 45'' \text{ or } 18''$$

Provided spacing is OK!





# Design of 90' x 60' Hall

## □ Solution [option 1b]

### ➤ Step 7: Detailing of Reinforcement

For crack control, the maximum spacing between the adjacent bars shall not exceed  $s_{max}$  (Table 24.3.2).

$$s_{max} = \text{Least of } 15 \left( \frac{40,000}{f_s} \right) - 2.5C_c \quad \text{and} \quad 12 \left( \frac{40,000}{f_s} \right)$$

$$f_s = \frac{2}{3} f_y = \frac{2}{3} (60,000) = 40,000 \text{ psi}$$

$$s_{max} = \text{Least of } 15 \left( \frac{40,000}{40,000} \right) - 2.5(3) \quad \text{and} \quad 12 \left( \frac{40,000}{40,000} \right) = 7.5''$$

Provided spacing of 7'' is OK. Finally provide #4@ 6'' c/c.



# Design of 90' x 60' Hall

## □ Solution [option 1b]

### ➤ Step 8: Drafting

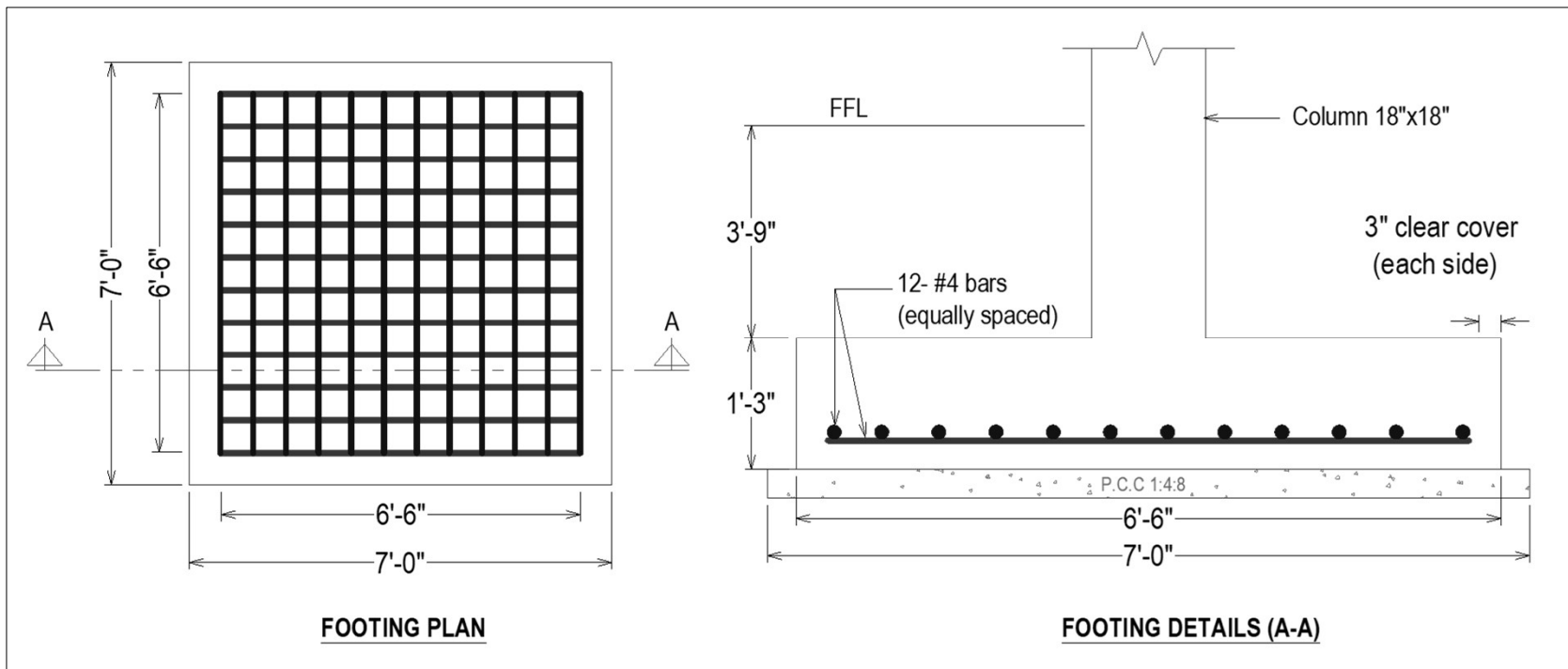



# Site Pictures

- ❑ Actual pictures of a hall of almost the same size in Peshawar University



Slab Reinforcement



Beam Reinforcement



# Site Pictures

- ❑ Actual pictures of a hall of almost the same size in Peshawar University

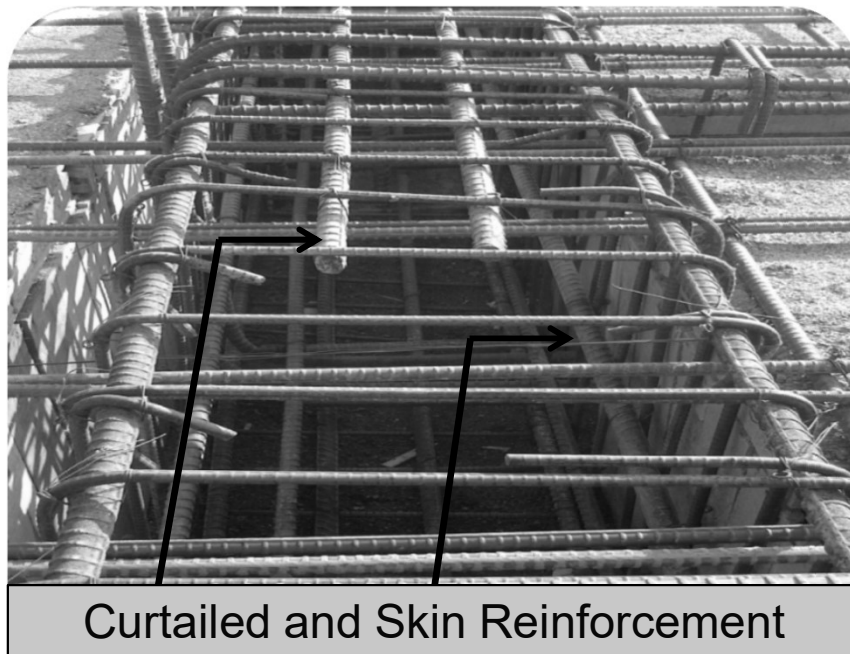



# Case Studies

- In the subsequent slides two case studies are carried out to investigate the variation of moments in beams, moments and slab thickness due to change in spacing between the beams.

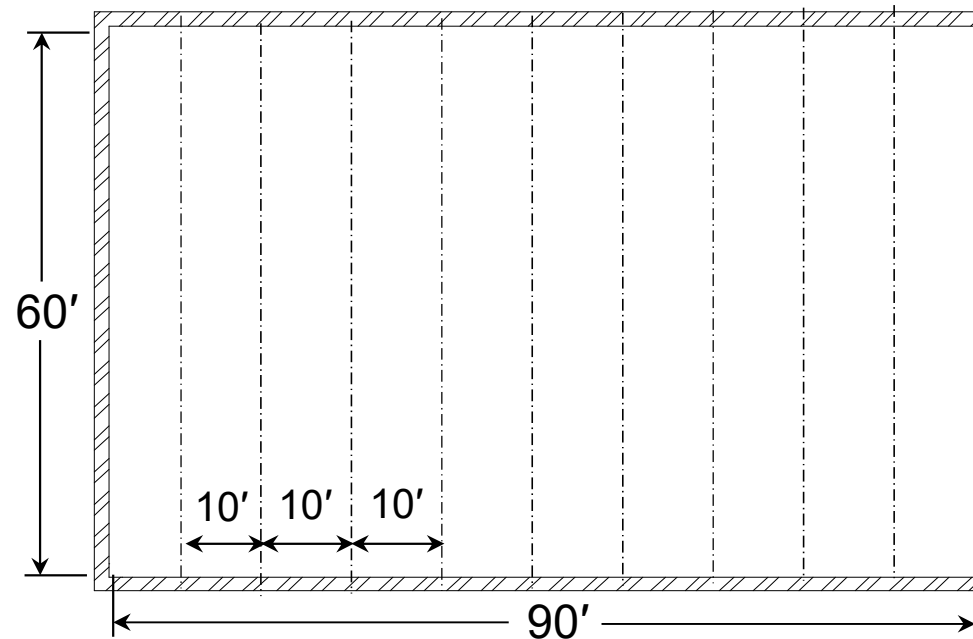



# Case Studies

## □ Case Study 01

- Variation of Slab Thickness and Moments Vs Spacing Between the Beams.

Variation of Slab thickness and Moments Vs Spacing Between Beams						
Parameters	Spacing Between the Beams (ft.)					
	10	12	14	16	18	20
Slab thickness (in.)	5.4 (Used 6)	6.4 (Used 6.5)	7.4 (Used 7.5)	8.4 (Used 8.5)	9.4 (Used 9.5)	10.4 (Used 10.5)
Max moment in slab (in-kip) (1/11 coefficient)	19.97	30.58	45.30	63.81	86.51	113.80
Area of steel (in <sup>2</sup> )	0.13	0.14	0.16	0.18	0.21	0.23
c/c spacing of #3 main bars (in.)	10.20	9.40	8.10	7.20	6.40	5.80

Note: Clear length ( $l_n$ ) =  $l_{c/c} - 0.75$  has been used in determining moments



# Case Studies

## □ Case Study 01

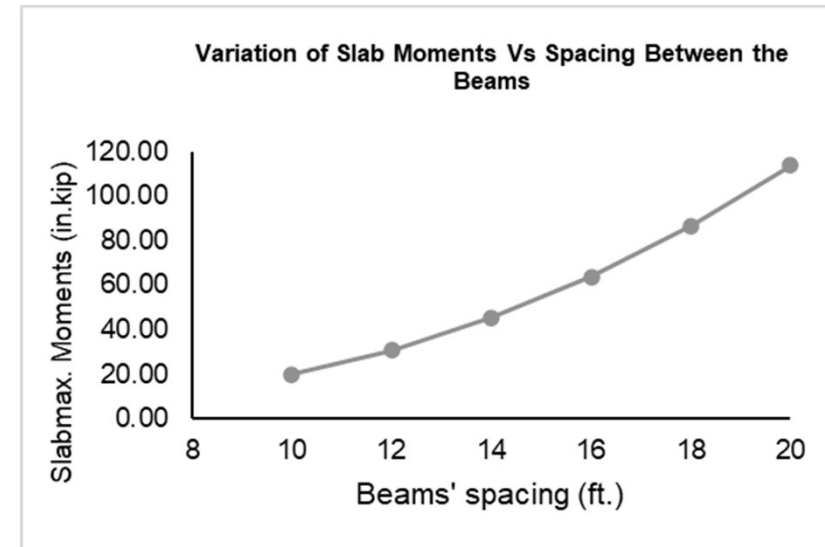
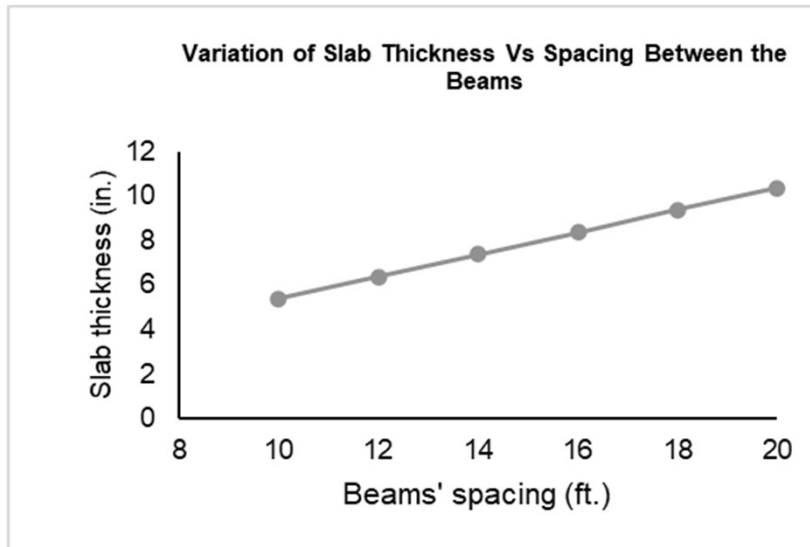



# Case Studies

## □ Case Study 02

- Variation of Moments in Beam Vs Spacing Between Beams

Variation of Beam Moments Vs Spacing Between Beams					
Parameters	Spacing Between the Beams (ft)				
	5	8	10	12	14
$W_u$ (k/ft)	2.285	2.927	3.355	3.873	4.526
$M_{u+}$ (in-kip)	957.04	1225.94	1405.20	1622.16	1895.66
$M_{u-}$ (in-kip)	12006.62	15380.03	17628.97	20350.82	23782.04
$A_s$ positive (in <sup>2</sup> )	3.93	5.04	5.79	6.69	7.84

### Note:

- Center-to-center length ( $l_{c/c} = 61.5'$ ) has been used in determining moments.
- Analysis done using simplified flexibility method.

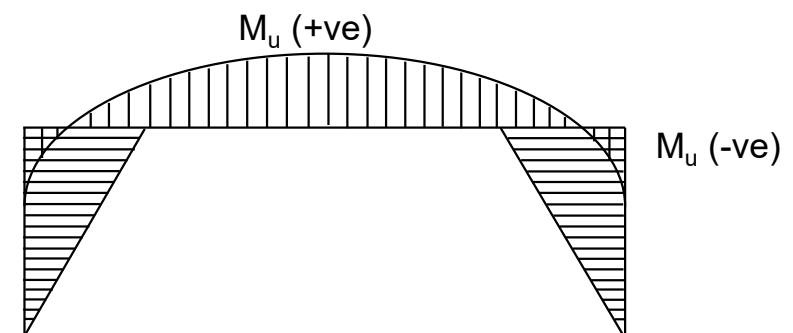





# Case Studies

## □ Case Study 02

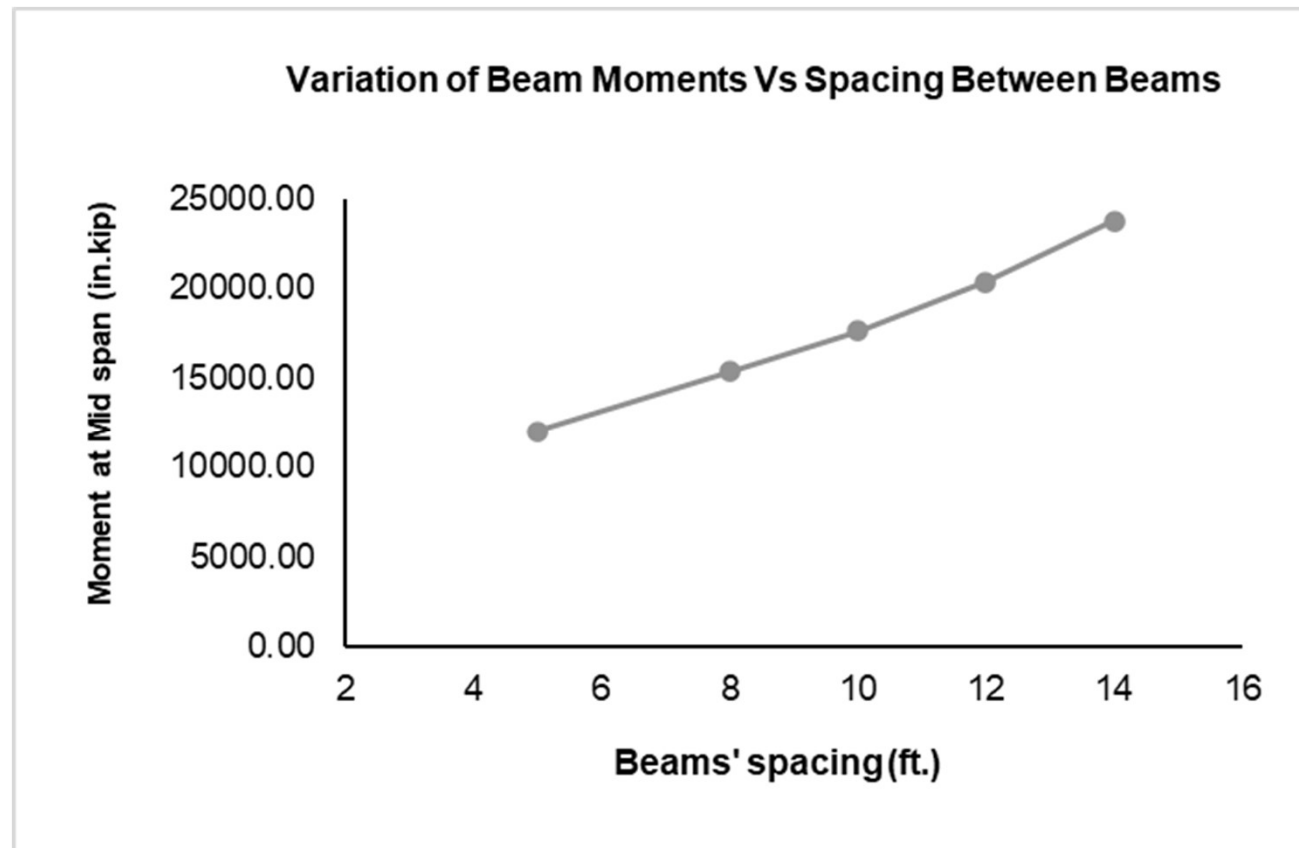



# Case Studies

## □ Conclusions

1. The thickness of slab increases linearly with an increase in spacing between beams.
2. The moments in a slab increase quadratically with an increase in the spacing between the beams.
3. The moments in beams increase linearly with an increase in the spacing between the beams.



## **The End of Part – I**

**Option 2** of the example will be covered  
in Part 2 of the lecture.



# References

- Design of Concrete Structures 14th / 15th edition by Nilson, Darwin and Dolan.
- Building Code Requirements for Structural Concrete (ACI 318-19)

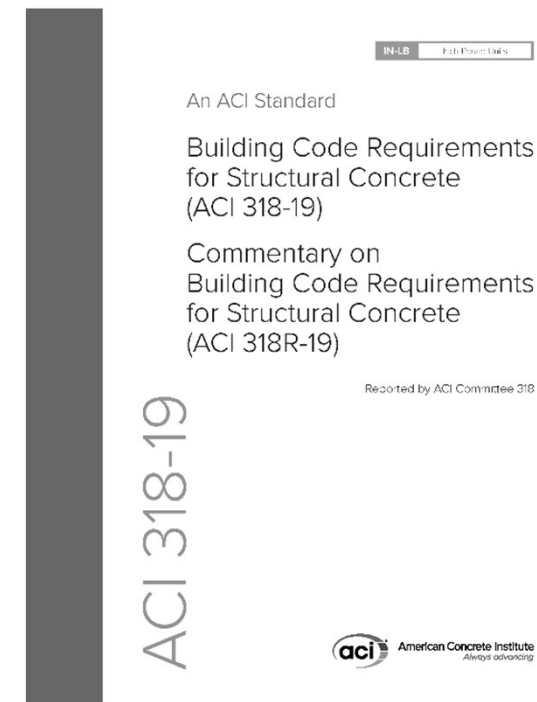
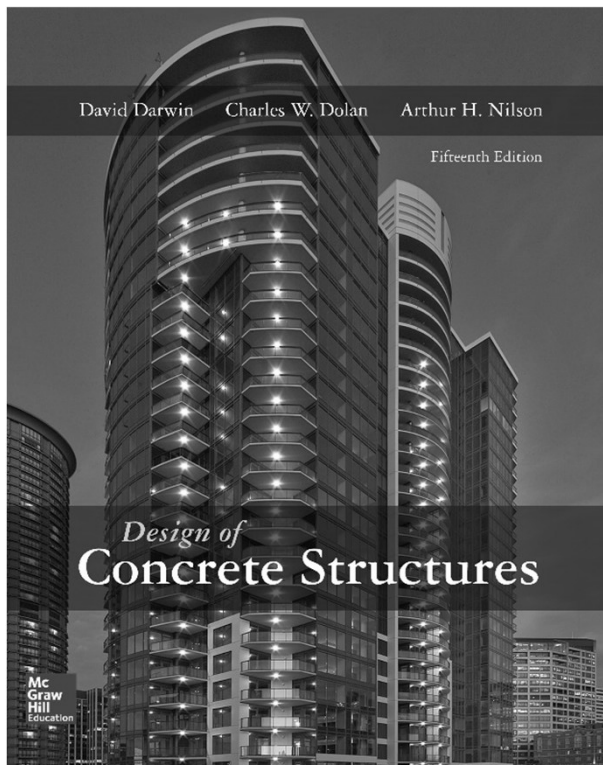



# Appendix

## □ Minimum Design Loads ( ASCE 7– 16 )

Table 4.3-1 Minimum Uniformly Distributed Live Loads,  $L_o$ , and Minimum Concentrated Live Loads

Occupancy or Use	Uniform, $L_o$ psf (kN/m <sup>2</sup> )	Live Load Reduction Permitted? (Sec. No.)	Multiple-Story Live Load Reduction Permitted? (Sec. No.)	Concentrated lb (kN)	Also See Section
<b>Apartments (See Residential)</b>					
<b>Access floor systems</b>					
Office use	50 (2.40)	Yes (4.7.2)	Yes (4.7.2)	2,000 (8.90)	
Computer use	100 (4.79)	Yes (4.7.2)	Yes (4.7.2)	2,000 (8.90)	
<b>Armories and drill rooms</b>	150 (7.18)	No (4.7.5)	No (4.7.5)		
<b>Assembly areas</b>					
Fixed seats (fastened to floors)	60 (2.87)	No (4.7.5)	No (4.7.5)		
Lobbies	100 (4.79)	No (4.7.5)	No (4.7.5)		
Movable seats	100 (4.79)	No (4.7.5)	No (4.7.5)		
Platforms (assembly)	100 (4.79)	No (4.7.5)	No (4.7.5)		
Stage floors	150 (7.18)	No (4.7.5)	No (4.7.5)		
Reviewing stands, grandstands, and bleachers	100 (4.79)	No (4.7.5)	No (4.7.5)		4.14
Stadiums and arenas with fixed seats (fastened to the floor)	60 (2.87)	No (4.7.5)	No (4.7.5)		4.14
Other assembly areas	100 (4.79)	No (4.7.5)	No (4.7.5)		
<b>Balconies and decks</b>	1.5 times the live load for the area served. Not required to exceed 100 psf (4.79 kN/m <sup>2</sup> )	Yes (4.7.2)	Yes (4.7.2)		
<b>Catwalks for maintenance access</b>	40 (1.92)	Yes (4.7.2)	Yes (4.7.2)	300 (1.33)	
<b>Corridors</b>					
First floor	100 (4.79)	Yes (4.7.2)	Yes (4.7.2)		
Other floors	Same as occupancy served except as indicated				



# Appendix

## □ Minimum Design Loads ( ASCE 7– 16 )

**Table 4.3-1 Minimum Uniformly Distributed Live Loads,  $L_o$ , and Minimum Concentrated Live Loads**

Occupancy or Use	Uniform, $L_o$ psf (kN/m <sup>2</sup> )	Live Load Reduction Permitted? (Sec. No.)	Multiple-Story Live Load Reduction Permitted? (Sec. No.)	Concentrated lb (kN)	Also See Section
<b>Dining rooms and restaurants</b>	100 (4.79)	No (4.7.5)	No (4.7.5)		
<b>Dwellings (See Residential)</b>					
<b>Elevator machine room grating</b> (on area of 2 in. by 2 in. (50 mm by 50 mm))		—	—	300 (1.33)	
<b>Finish light floor plate construction</b> (on area of 1 in. by 1 in. (25 mm by 25 mm))		—	—	200 (0.89)	
<b>Fire escapes</b>	100 (4.79)	Yes (4.7.2)	Yes (4.7.2)		
On single-family dwellings only	40 (1.92)	Yes (4.7.2)	Yes (4.7.2)		
<b>Fixed ladders</b>		—	—	See Sec. 4.5.4	
<b>Garages</b> (See Section 4.10)					
Passenger vehicles only	40 (1.92)	No (4.7.4)	Yes (4.7.4)	See Sec. 4.10.1	
Trucks and buses	See Sec. 4.10.2	—	—	See Sec. 4.10.2	
<b>Handrails and Guardrails</b>	See Sec. 4.5.1	—	—	See Sec. 4.5.1	
Grab bars		—	—	See Sec. 4.5.2	
<b>Helipads</b> (See Section 4.11)					
Helicopter takeoff weight 3,000 lb (13.35 kN) or less	40 (1.92)	No (4.11.1)	—	See Sec. 4.11.2	
Helicopter takeoff weight more than 3,000 lb (13.35 kN)	60 (2.87)	No (4.11.1)	—	See Sec. 4.11.2	
<b>Hospitals</b>					
Operating rooms, laboratories	60 (2.87)	Yes (4.7.2)	Yes (4.7.2)	1,000 (4.45)	
Patient rooms	40 (1.92)	Yes (4.7.2)	Yes (4.7.2)	1,000 (4.45)	
Corridors above first floor	80 (3.83)	Yes (4.7.2)	Yes (4.7.2)	1,000 (4.45)	



# Appendix

## □ DESIGN AIDS (DA – 1 )

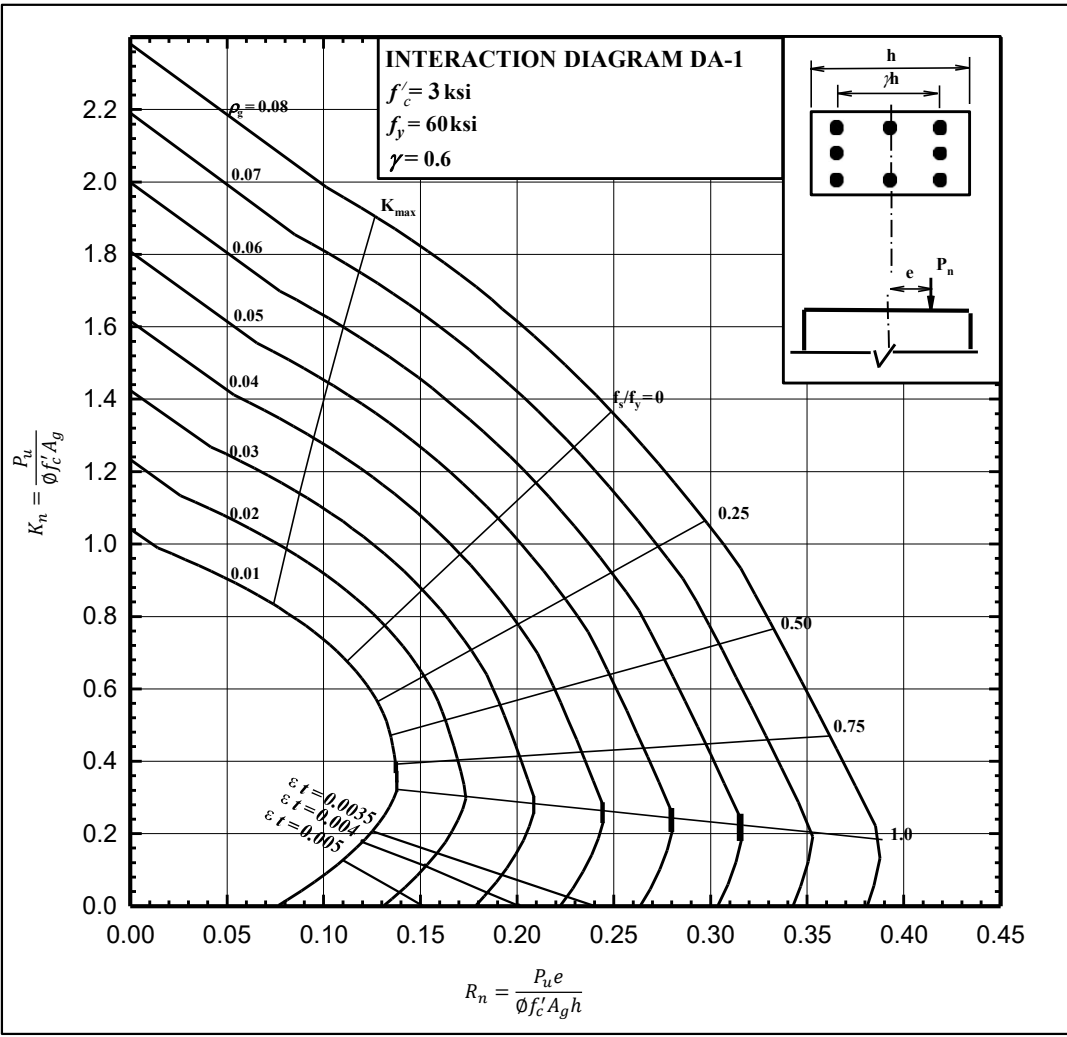



# Appendix

## □ DESIGN AIDS (DA – 2 )

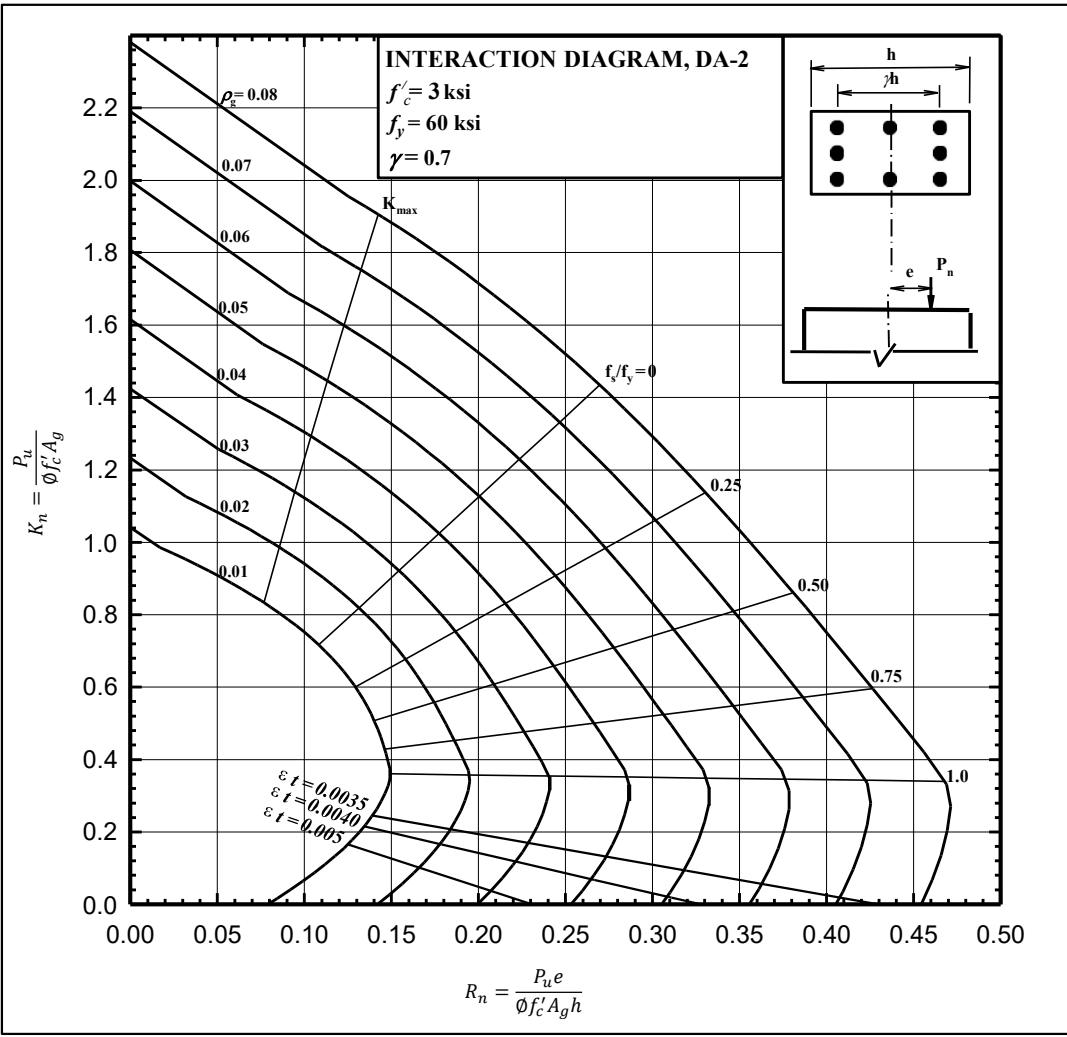





# Appendix

## □ DESIGN AIDS (DA – 3)

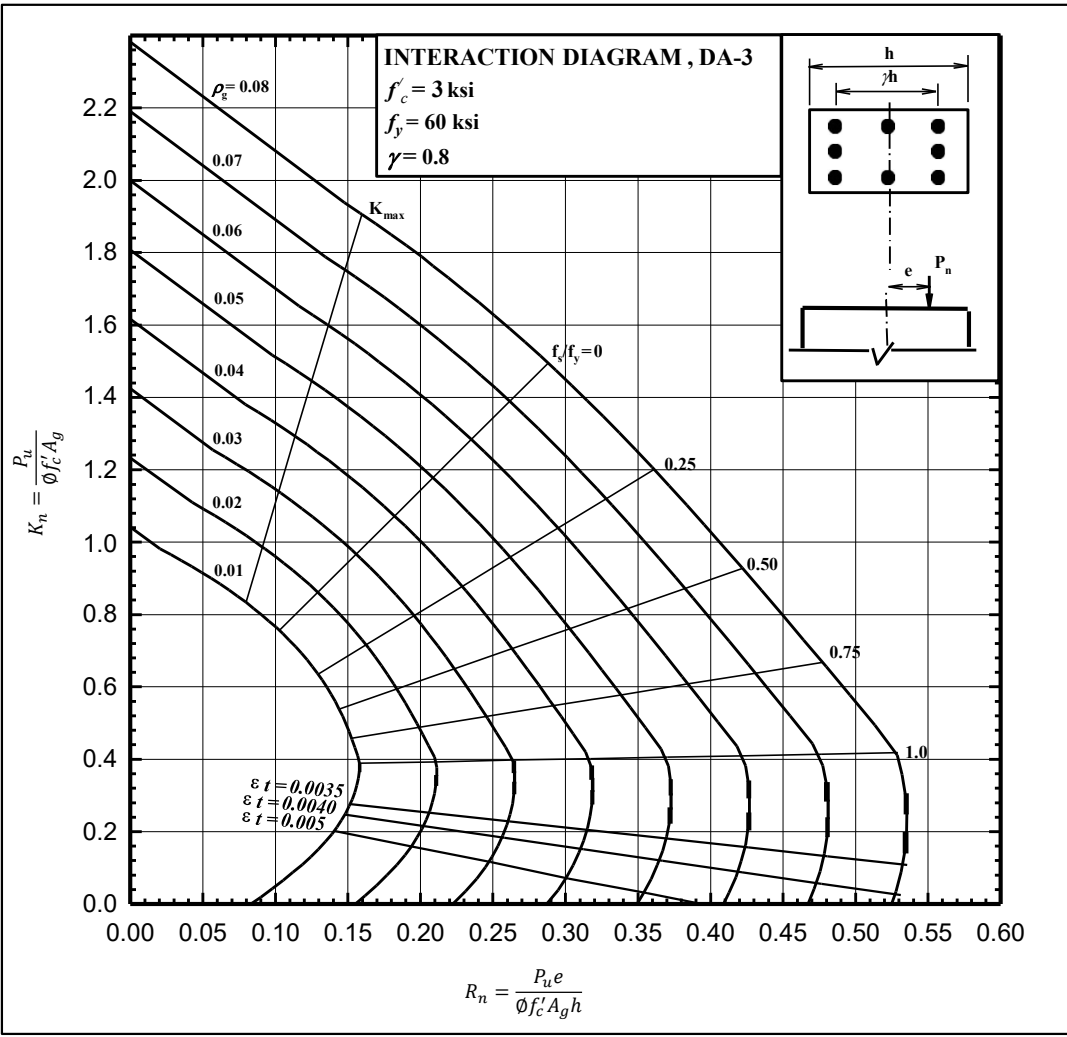



# Appendix

## □ DESIGN AIDS (DA – 4)

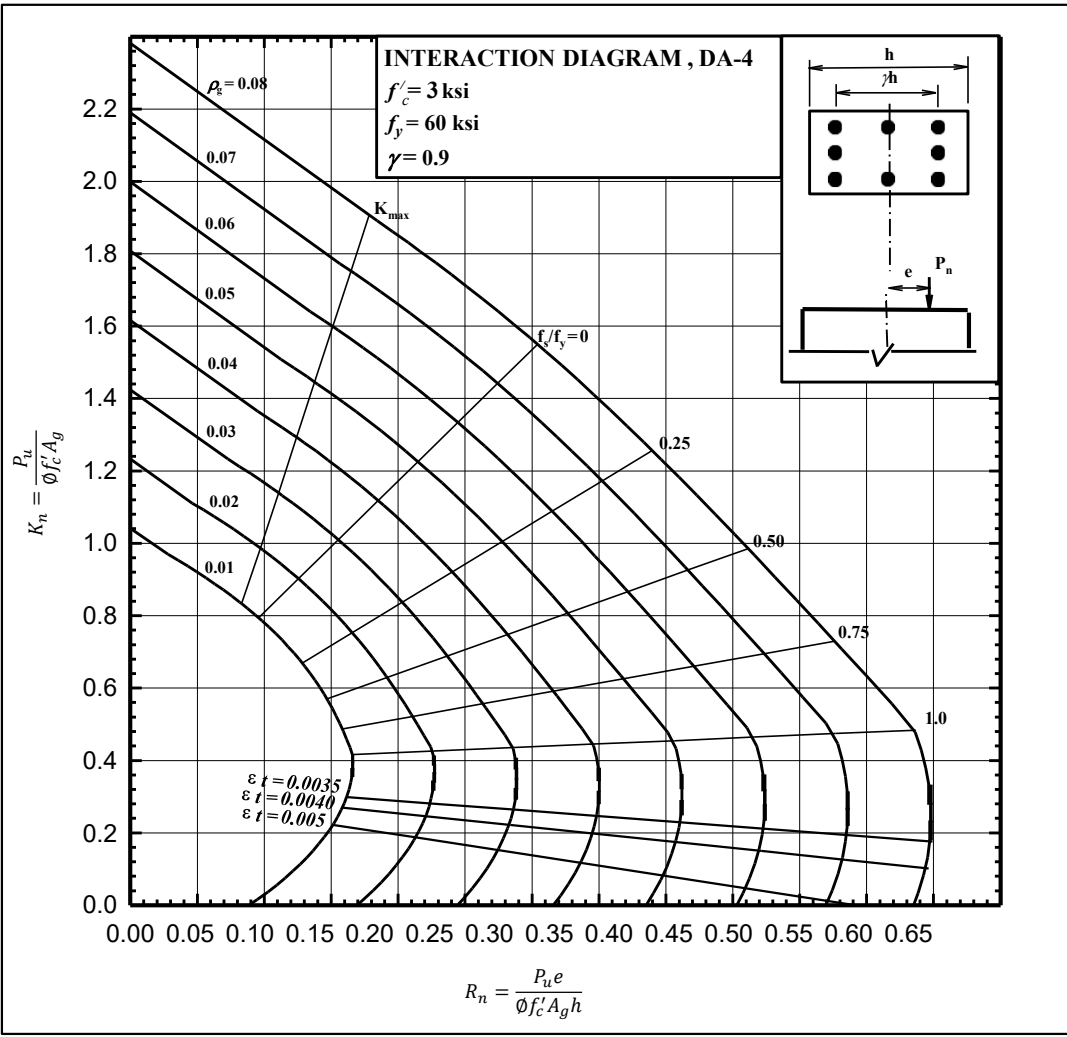



# Appendix

## □ DESIGN AIDS (DA – 5)

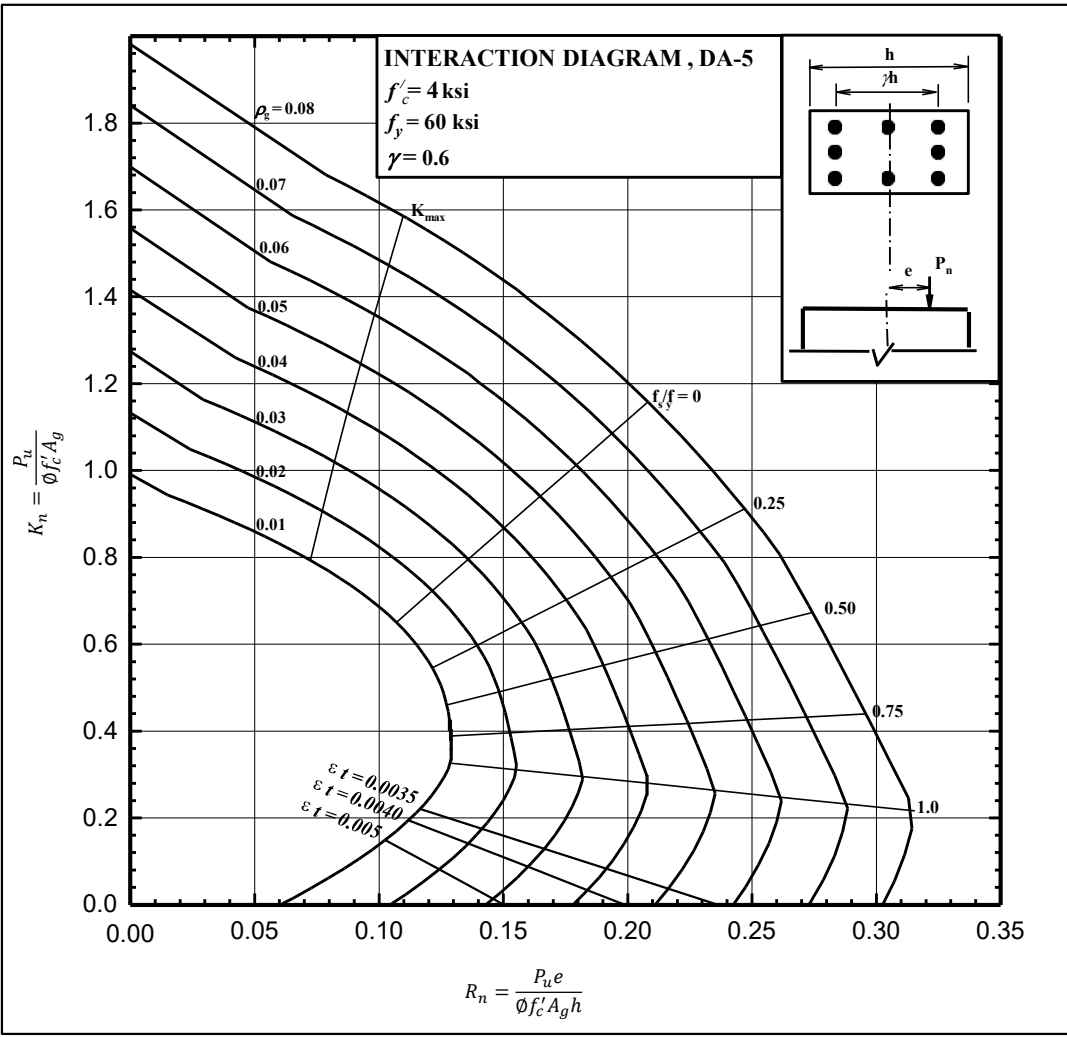



# Appendix

## □ DESIGN AIDS (DA – 6)

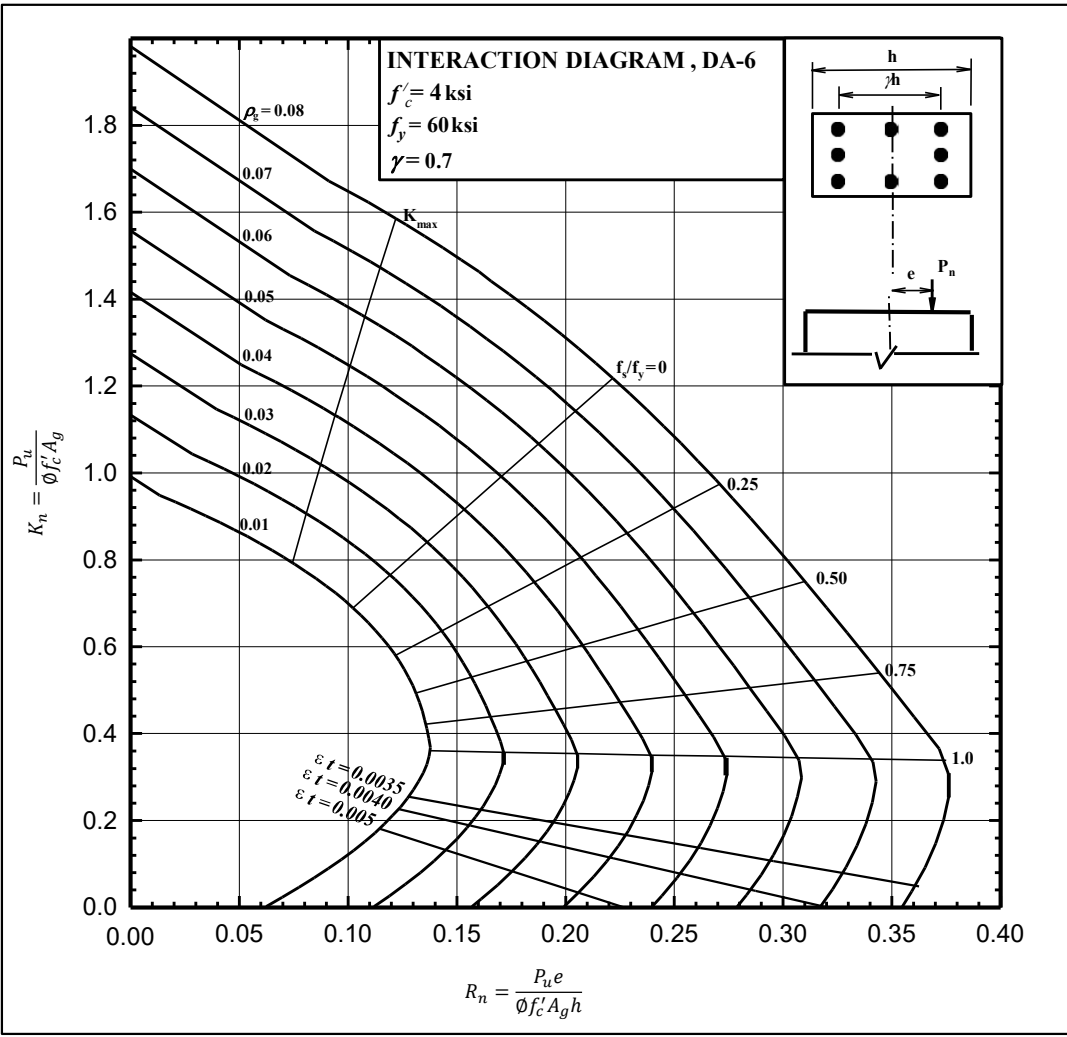



# Appendix

## □ DESIGN AIDS (DA – 7)

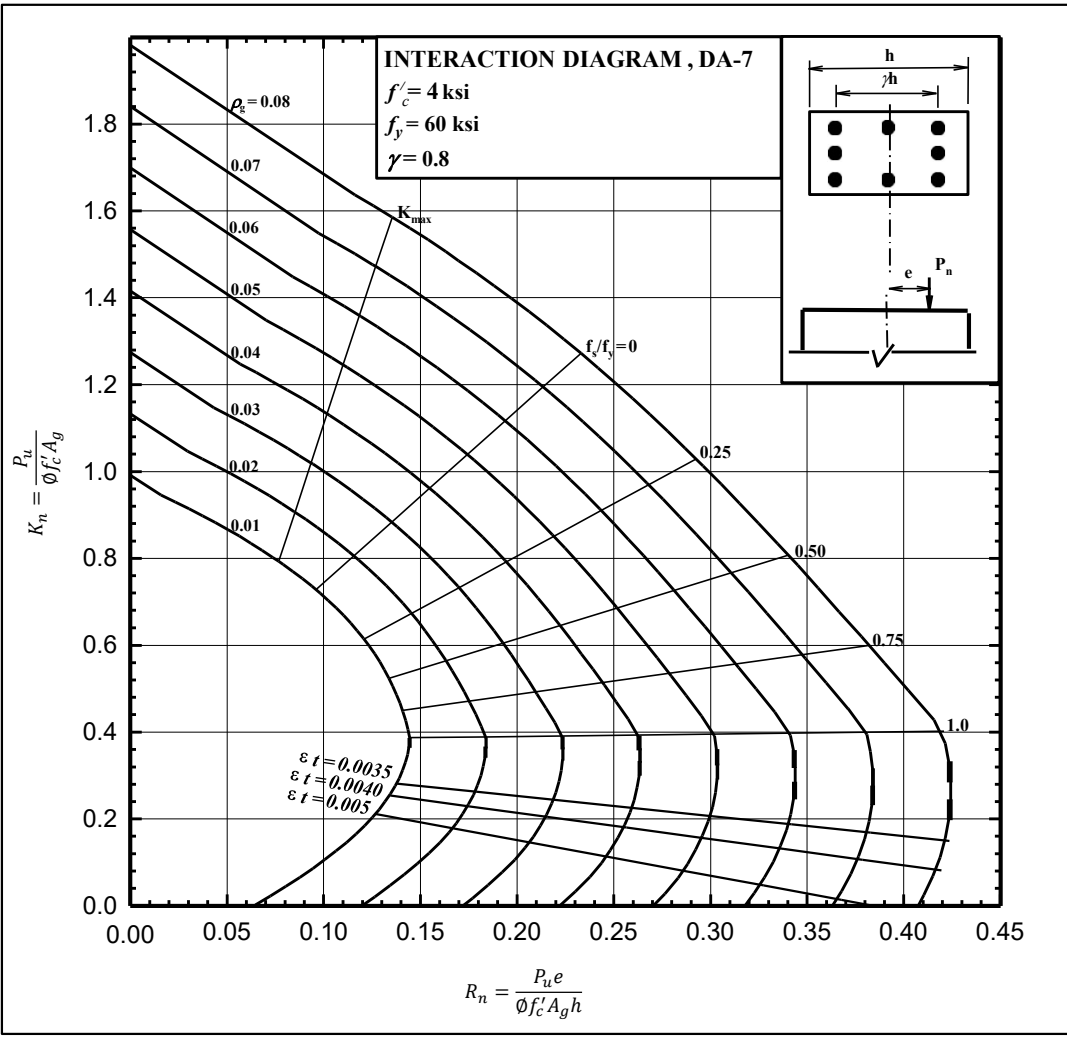



# Appendix

## □ DESIGN AIDS (DA – 8)

