



## Lecture 05

# Introduction to Earthquake Resistant Design of RC Structures (Part – II)

By:

Prof. Dr. Qaisar Ali

Civil Engineering Department

UET Peshawar

[drqaisarali@uetpeshawar.edu.pk](mailto:drqaisarali@uetpeshawar.edu.pk)

[www.drqaisarali.com](http://www.drqaisarali.com)



# Lecture Contents

- Behavior of RC buildings under Seismic loading
- ACI Special Provisions for Seismic Design of RC Buildings
  - General requirements
  - ACI Provisions for Special Moment Frames (SMF)
  - ACI Provisions for Intermediate Moment Frames (IMF)
- Example 6.3 on Special moment frame
- References



# Learning Outcomes

- ❑ **At the end of this lecture, students will be able to;**
  - **Outline** ACI Provisions related to Earthquake resistant design of structures
  - **Evaluate** RC Members for Special Moment Frame Provisions



# Behavior of RC buildings under Seismic loading

## □ Gravity loading vs Earthquake loading in RC buildings

- Under gravity loads, tension in the beams is at bottom midspan and is at top at the ends.
- On the other hand, earthquake loading causes tension in the beam and column faces at locations different from those under gravity loading.
- Hence steel bars are required on both faces of beams to resist reversals of bending moment.





# ACI Special Provisions for Seismic Design of RC Buildings

## □ Objectives of ACI special provisions

- The principal goal of the **Special Provisions** is to ensure adequate toughness under inelastic displacement reversals brought on by earthquake loading.
- The provisions accomplish this goal by requiring the designer to provide adequate **concrete confinement**.



# ACI Special Provisions for Seismic Design of RC Buildings

## □ Reinforced Concrete Moment Frames

- Based on moment resisting capacity, there are three types of RC frames
  1. **Special Moment Frame (SMF)**
  2. **Intermediate Moment Frame (IMF)**
  3. **Ordinary Moment Frame (OMF)**
- We will start by outlining a few provisions that apply to all frames in general.
- Later, specific provisions for each type of frame will be discussed.



# ACI Special Provisions for Seismic Design of RC Buildings

## ☐ Reinforced Concrete Moment Frames

- Please note that **only few important** and not all provisions have been discussed in subsequent slides. For details, refer ACI chapter 18.
- Furthermore, also note that IMF and Two-way slab system without beams are not allowed in seismic zones 3 and 4.



# ACI Special Provisions for Seismic Design of RC Buildings

## □ General Provisions

### ❖ Material Properties

- Specified compressive strength of concrete in members resisting earthquake induced forces, shall not be less than **3000 psi** (cylinder strength) as per Table 19.2.1.1.
- There is no limit on the maximum value of  $f_c'$  for normal weight concrete.





# ACI Special Provisions for Seismic Design of RC Buildings

## □ General Provisions

### ❖ Material Properties (20.2.2.5)

- Deformed longitudinal reinforcement resisting earthquake-induced moment shall be in accordance with (a) or (b)
  - a) **ASTM A706 (low alloy steel):** Grade 60 and 80
  - b) **ASTM A615 (Billet steel):**
    - Grade 80 is not permitted
    - Grade 60 with certain conditions listed below.



# ACI Special Provisions for Seismic Design of RC Buildings

## □ General Provisions

### ❖ Material Properties (20.2.2.5)

#### a) ASTM A615 (Billet steel):

- i. Actual  $f_y$  – specified  $f_y \leq 18ksi$
- ii. Ratio of actual ultimate tensile strength to actual yield strength shall be at least 1.25
- iii. Minimum elongation in 8 inches long bar shall be at least
  - 14% for #3 to #6
  - 12% for #7 to #11
  - 10% for #14 and #18



# ACI Special Provisions for Seismic Design of RC Buildings

## 1. ACI Provisions for Special Moment Frames (SMF)

### ❖ Provisions for Beams (18.6.2)

#### i. Dimensional Limits (18.6.2.1)

a. Ratio of clear span  $l_n$  to the effective depth  $d$  shall be at least 4 ( $l_n/d \geq 4$ )

e.g., for  $L_n = 15$  ft,  $d = 16$ ",  $L_n/d = 15 \times 12/16 = 11.25 > 4$ , O.K.

b. Ratio of width  $b_w$  to depth  $h$  shall be at least 0.3 ( $b_w/h \geq 0.3$ )

e.g., for width,  $b = 12$ " and depth,  $h = 18$ ",  $b/h = 12/18 = 0.67 > 0.3$ , O.K.

c. Minimum width  $b_w$  shall not be less than 10"



# ACI Special Provisions for Seismic Design of RC Buildings

## 1. ACI Provisions for Special Moment Frames (SMF)

### ❖ Provisions for Beams (18.6.2)

#### ii. Flexural reinforcement (18.6.3)

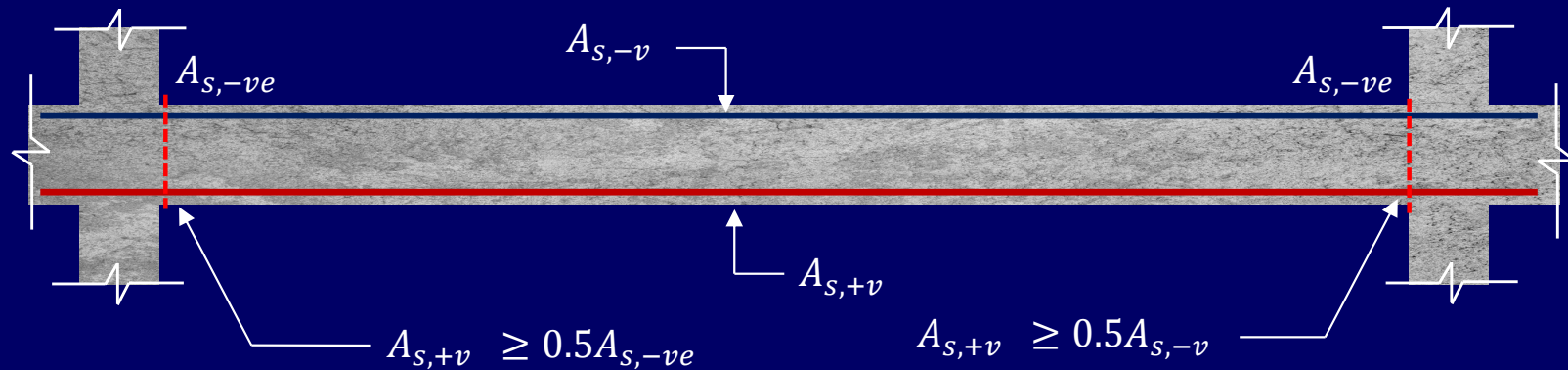

1. Minimum 2 bars continuous at all locations
2. At ends of beams;  $A_{s,+v} \geq 0.5A_{s,-ve}$
3.  $A_{s,min} = \text{larger of } \left( \frac{3\sqrt{f_c'}}{f_y}, \frac{200}{f_y} \right) bd$  (at critical locations) and  $A_{s,max} = 0.025bd$  (for Grade 60)
4.  $A_{s,-ve}$  or  $A_{s,+ve}$  (at all sections)  $\geq$  (maximum of  $A_s$  at either joint)/4



# ACI Special Provisions for Seismic Design of RC Buildings

## 1. ACI Provisions for Special Moment Frames (SMF)

### ❖ Provisions for Beams (18.6.2)

#### ii. Transverse reinforcement (18.6.4)

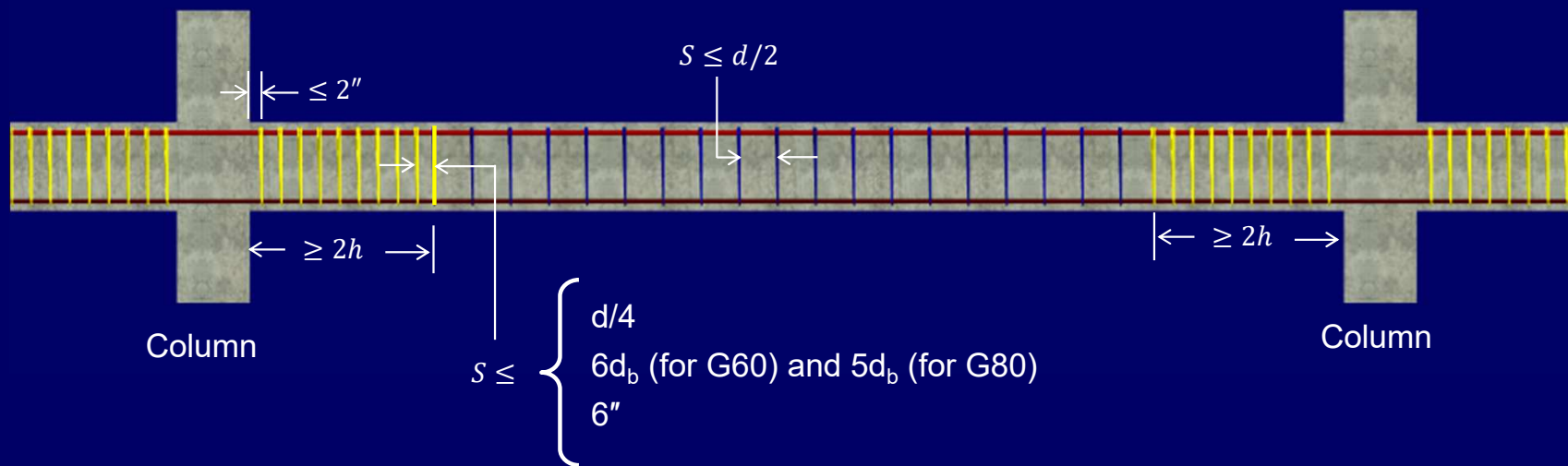



# ACI Special Provisions for Seismic Design of RC Buildings

## 1. ACI Provisions for Special Moment Frames (SMF)

### ❖ Provisions for Beams (18.6.2)

#### iii. Splices (18.6.3.3)

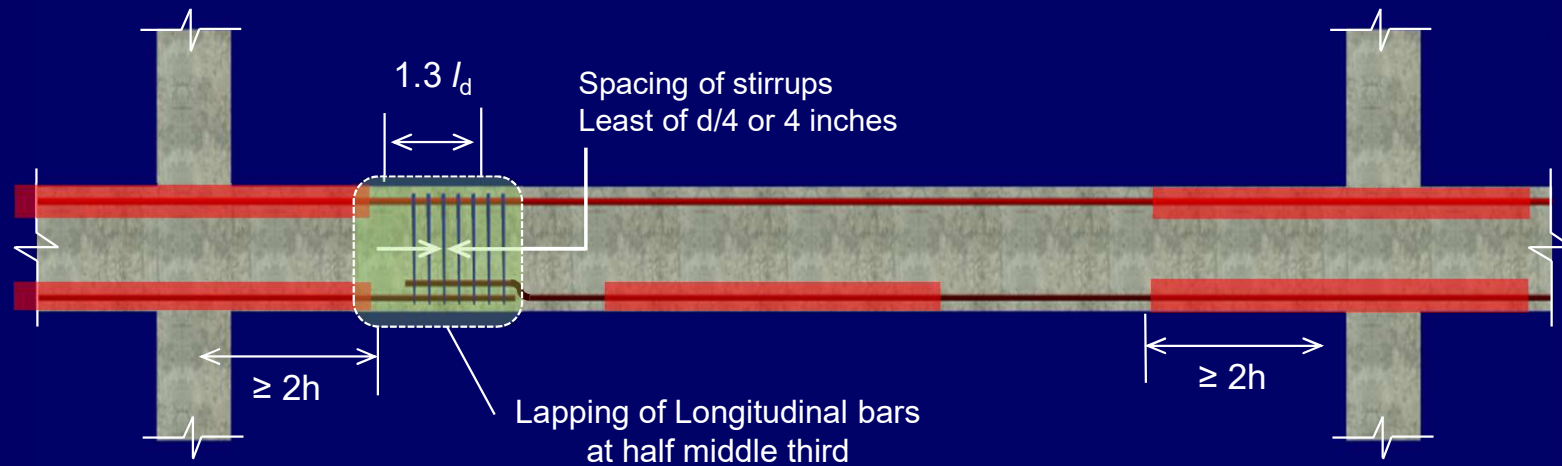

**■** Lapping is not allowed in regions where, longitudinal bars can yield in tension

$$\text{Lap splice length} = 1.3 l_d = 1.3 \times 0.05 (f_y / \sqrt{f_c'}) d_b$$

$$\mathbf{70 d_b} \text{ for } f_c' = 3 \text{ ksi and } f_y = 60 \text{ ksi}$$



# ACI Special Provisions for Seismic Design of RC Buildings

## 1. ACI Provisions for Special Moment Frames (SMF)

### ❖ Provisions for Beams (18.6.2)

#### iii. Splices (18.6.3.3)

- **Mechanical** (section 25.5.7) and **welded splices** (section 18.2.8) are permitted at the same half middle third location as shown on previous slide and should have strength of at least  $1.25f_y$ .



# ACI Special Provisions for Seismic Design of RC Buildings

## 1. ACI Provisions for Special Moment Frames (SMF)

### ❖ Provisions for Columns (18.7)

#### i. Dimensional limits (18.7.2)

- a) The shortest cross-sectional dimension shall be at least 12"
- b) The ratio of the shortest cross-sectional dimension to the perpendicular dimension shall be at least 0.4

For example; 12/12, 12/18, 12/24 OK; but 12/36 is not O.K





# ACI Special Provisions for Seismic Design of RC Buildings

## 1. ACI Provisions for Special Moment Frames (SMF)

### ❖ Provisions for Columns (18.7)

#### ii. Longitudinal reinforcement (18.7.4)

- a) Minimum Area of longitudinal reinforcement,  $A_{st}$ , shall be at least  $0.01A_g$
- b) Maximum Area of longitudinal reinforcement,  $A_{st}$ , shall not exceed  $0.06A_g$ .

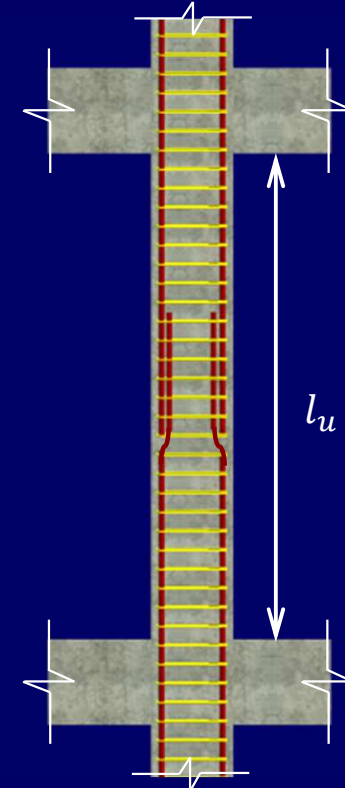



# ACI Special Provisions for Seismic Design of RC Buildings

## 1. ACI Provisions for Special Moment Frames (SMF)

### ❖ Provisions for Columns (18.7)

#### iii. Transverse reinforcement (18.7.5)

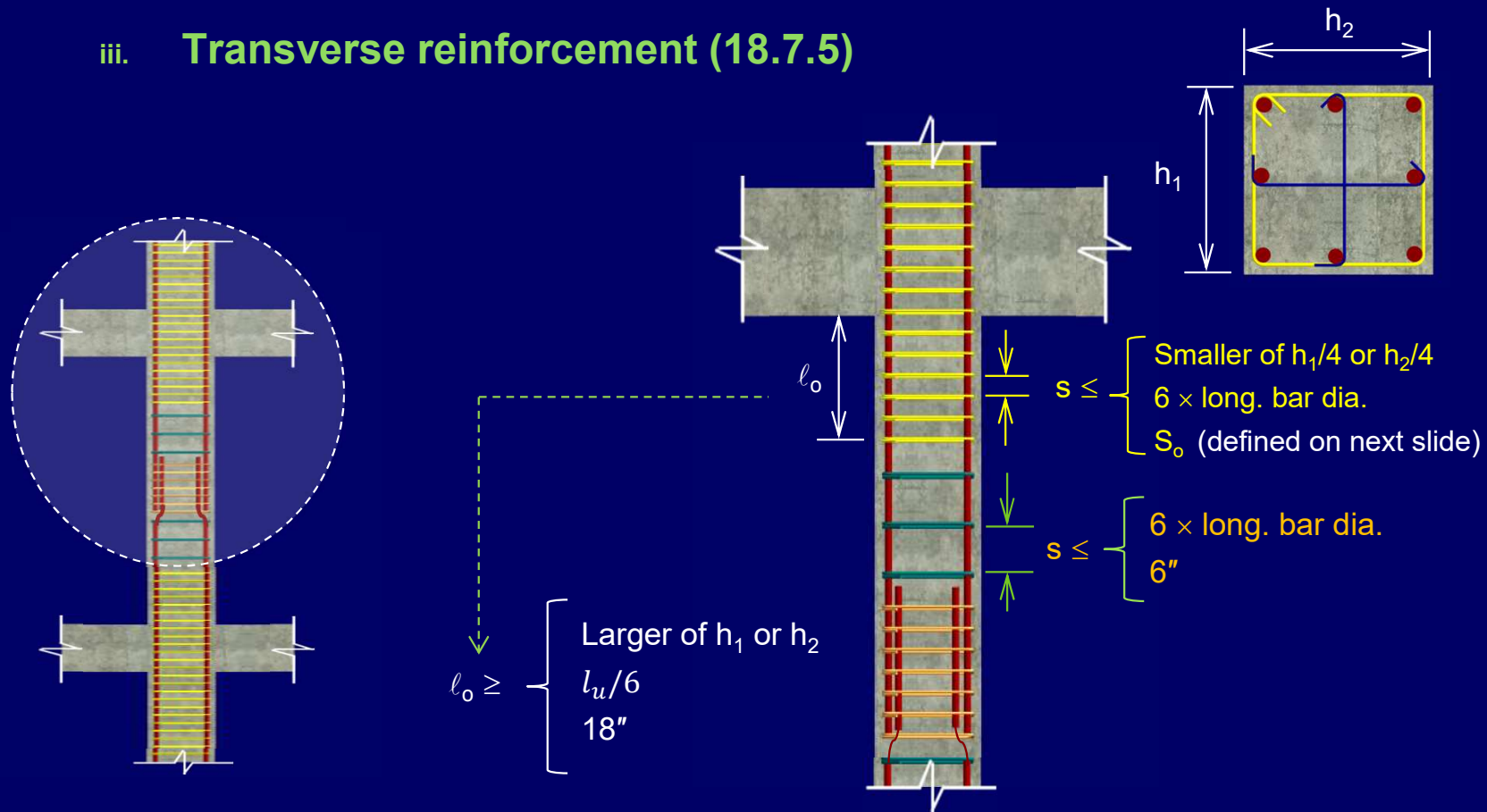



# ACI Special Provisions for Seismic Design of RC Buildings

## 1. ACI Provisions for Special Moment Frames (SMF)

### ❖ Provisions for columns (18.7)

#### iii. Transverse reinforcement (18.7.5)

 Continuous (Ties)

 Cross Tie

Where;

$$4'' \leq S_o = 4 + \left( \frac{14 - h_x}{3} \right) \leq 6''$$

and

$h_x = \text{max. value of } h_x \text{ on all column faces}$

$h_x \leq 14''$

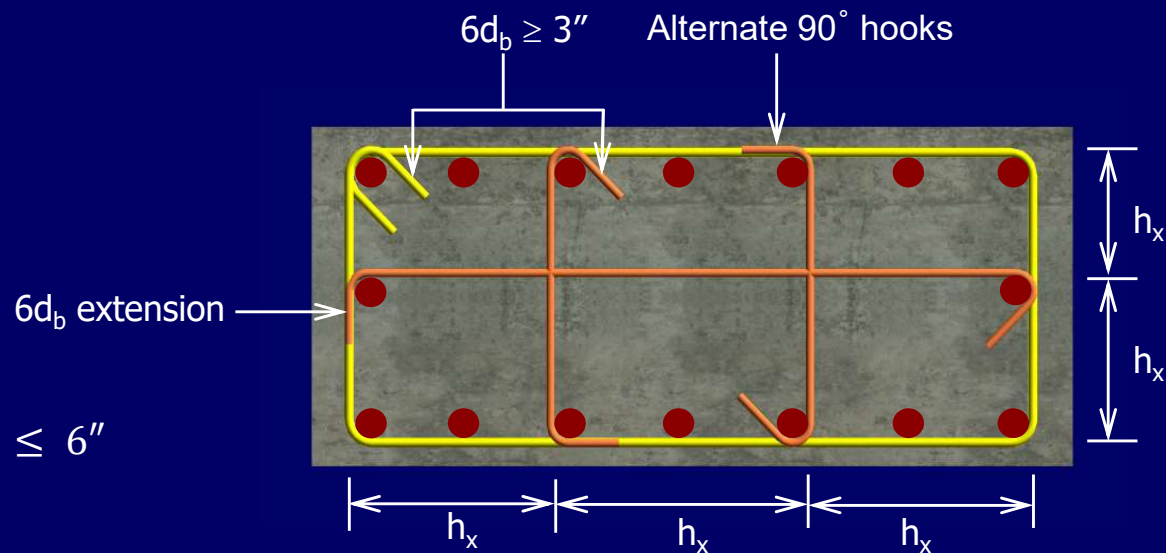



# ACI Special Provisions for Seismic Design of RC Buildings

## 1. ACI Provisions for Special Moment Frames (SMF)

### ❖ Provisions for columns (18.7)

#### iv. Lap Splices (18.7.4.4)

Tension lap splice within center half of column

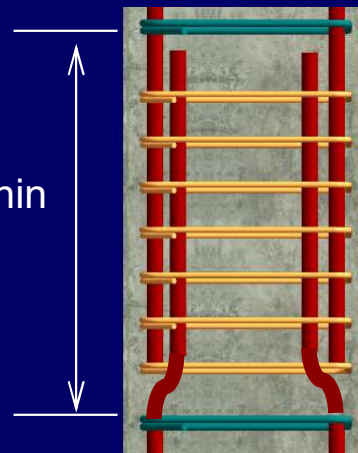

$s = \min (d/4 \text{ or } 4")$

$$\text{Lap splice length} = 1.3 l_d = 1.3 \times 0.05 (f_y / \sqrt{f_c'}) d_b$$

**70  $d_b$**  for  $f_c' = 3 \text{ ksi}$  and  $f_y = 60 \text{ ksi}$

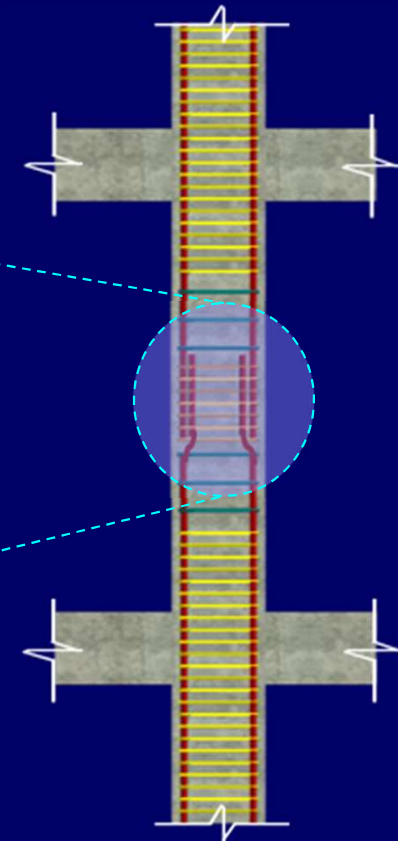



# ACI Special Provisions for Seismic Design of RC Buildings

## 1. ACI Provisions for Special Moment Frames (SMF)

### ❖ Joints of Special Moment Frames (18.8)

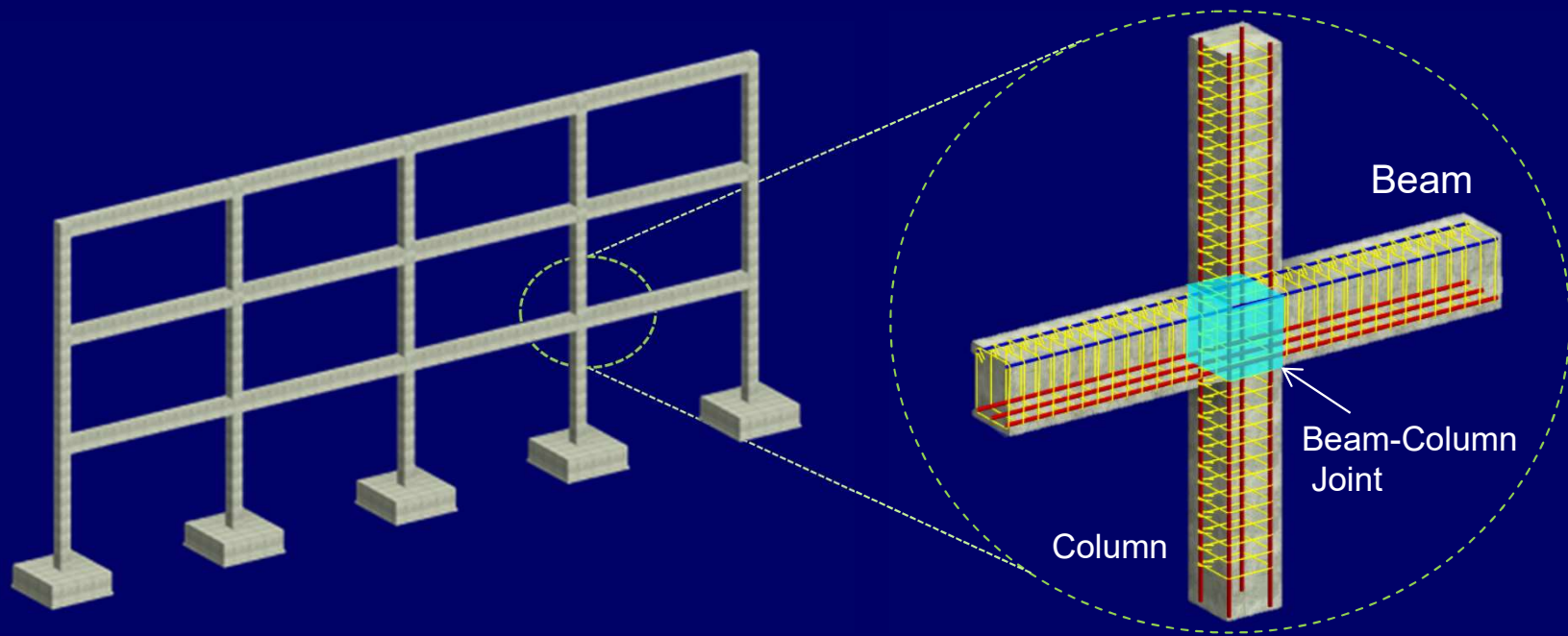



# ACI Special Provisions for Seismic Design of RC Buildings

## 1. ACI Provisions for Special Moment Frames (SMF)

### ❖ Joints of Special Moment Frame (18.8)

- Column ties (with 135deg hook) to be continued through joint.

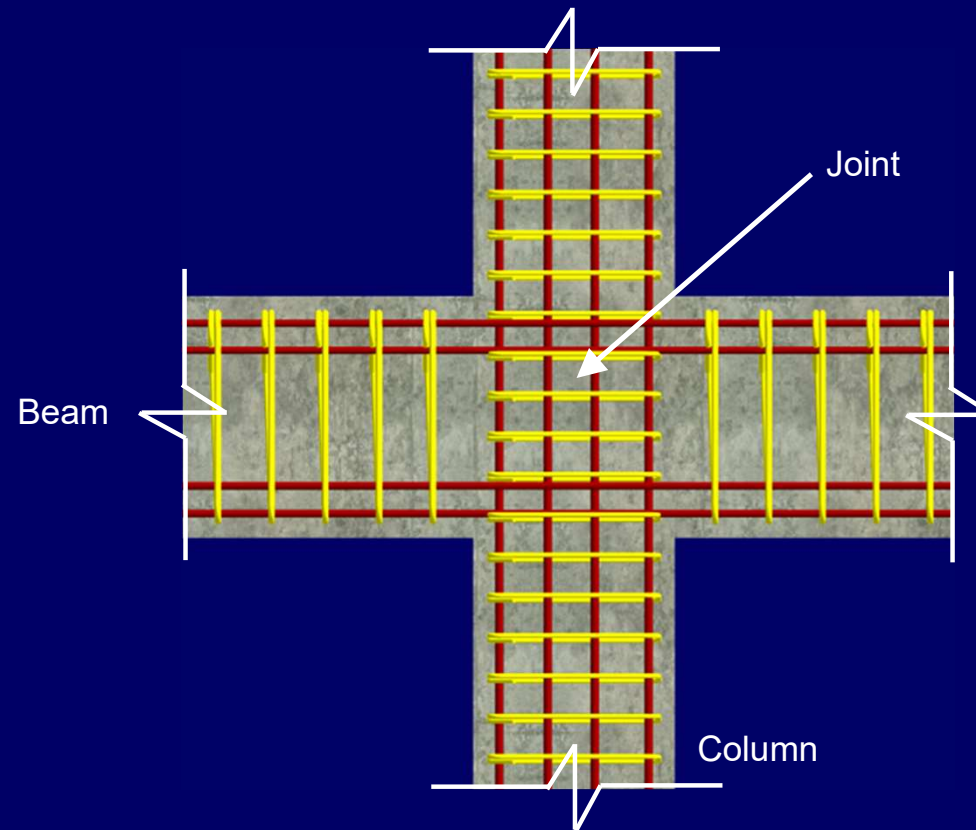



# ACI Special Provisions for Seismic Design of RC Buildings

## 1. ACI Provisions for Special Moment Frames (SMF)

### ❖ Joints of Special Moment Frame (18.8)

- The depth  $h$  of the joint parallel to the beam longitudinal reinforcement shall be at least **20 times** diameter of largest Grade 60 longitudinal bar.

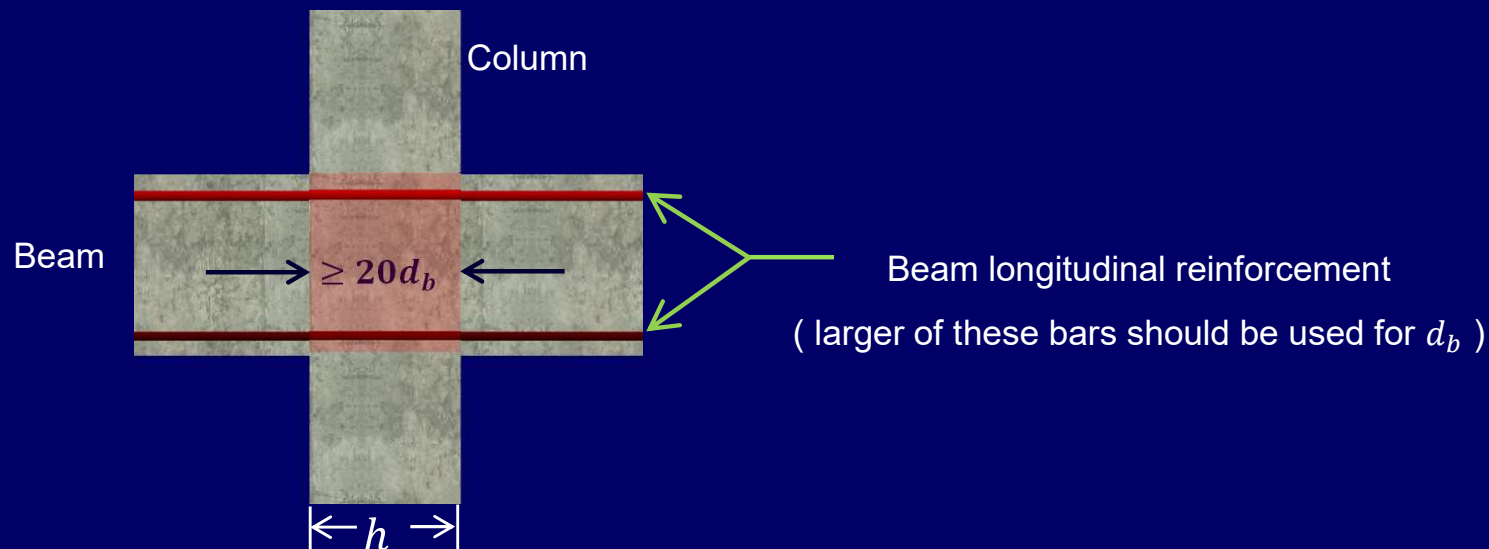



# ACI Special Provisions for Seismic Design of RC Buildings

## 1. ACI Provisions for Special Moment Frames (SMF)

### ❖ Joints of Special Moment Frame (18.8)

- Beam longitudinal reinforcement that is terminated within a column, must be extended to the far face of the column core.
- The development length  $l_{dh}$  of bars with 90° hooks must be not less than  $8d_b$ , 6", or  $f_y d_b / 65 \sqrt{f'_c}$

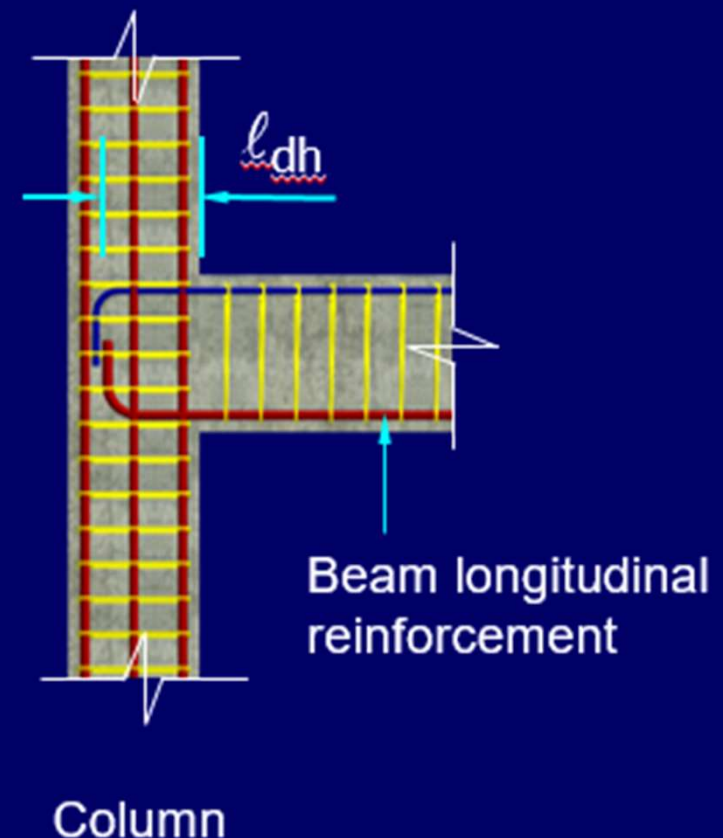





# ACI Special Provisions for Seismic Design of RC Buildings

## 1. ACI Provisions for Special Moment Frames (SMF)

### ❖ Joints of Special Moment Frame

- Experimental tests





# ACI Special Provisions for Seismic Design of RC Buildings

## 2. ACI Provisions for Intermediate Moment Frames (IMF)

### ❖ Provisions for beams (18.6.2)

- **Size:** No special requirements, just as ordinary beam requirement
- **Flexural reinforcement:** Less stringent requirement as discussed next.
- **Transverse reinforcement:** Same as for SMF.
- **Lap Splices:** No special requirements (just as ordinary beam requirement).



# ACI Special Provisions for Seismic Design of RC Buildings

## 2. ACI Provisions for Intermediate Moment Frames (IMF)

### ❖ Provisions for Beams

#### i. Flexural reinforcement (18.4.2)

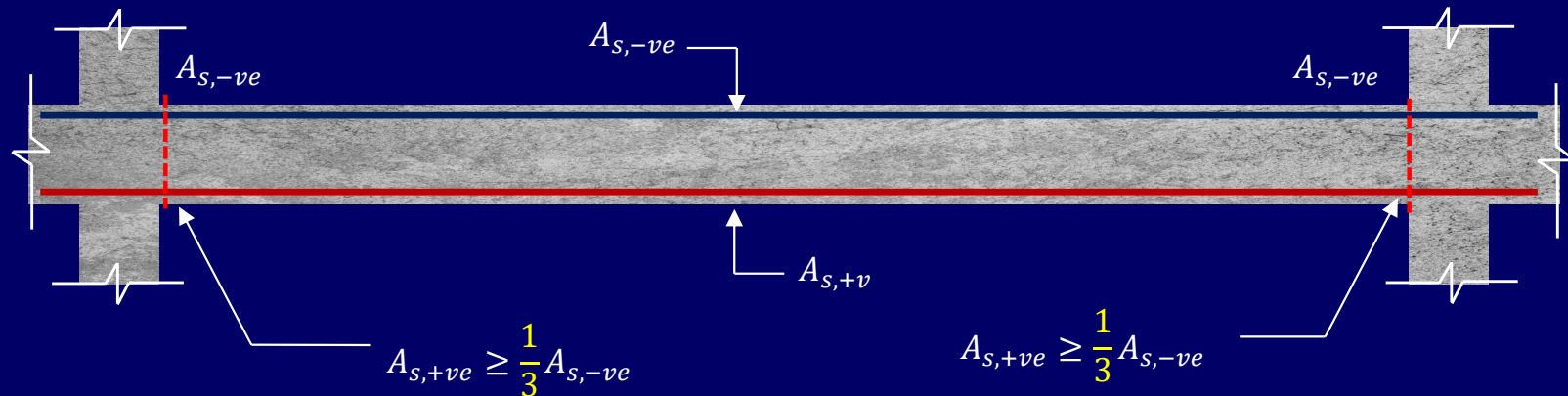

*Minimum 2 bars continuous at all locations*

$A_{s,-ve}$  or  $A_{s,+ve}$  (at all sections)  $\geq$  (maximum of  $A_s$  at either joint) / 5



# ACI Special Provisions for Seismic Design of RC Buildings

## 2. ACI Provisions for Intermediate Moment Frames (IMF)

### ❖ Provisions for Columns (18.4.3)

- **Size:** No special requirements
- **Longitudinal reinforcement:** No special requirements
- **Transverse reinforcement:** Less Stringent requirement as given next.
- **Lap:** No special requirements



# ACI Special Provisions for Seismic Design of RC Buildings

## 2. ACI Provisions for Intermediate Moment Frames (IMF)

### ❖ Provisions for columns (18.4.3)

#### i. Transverse reinforcement

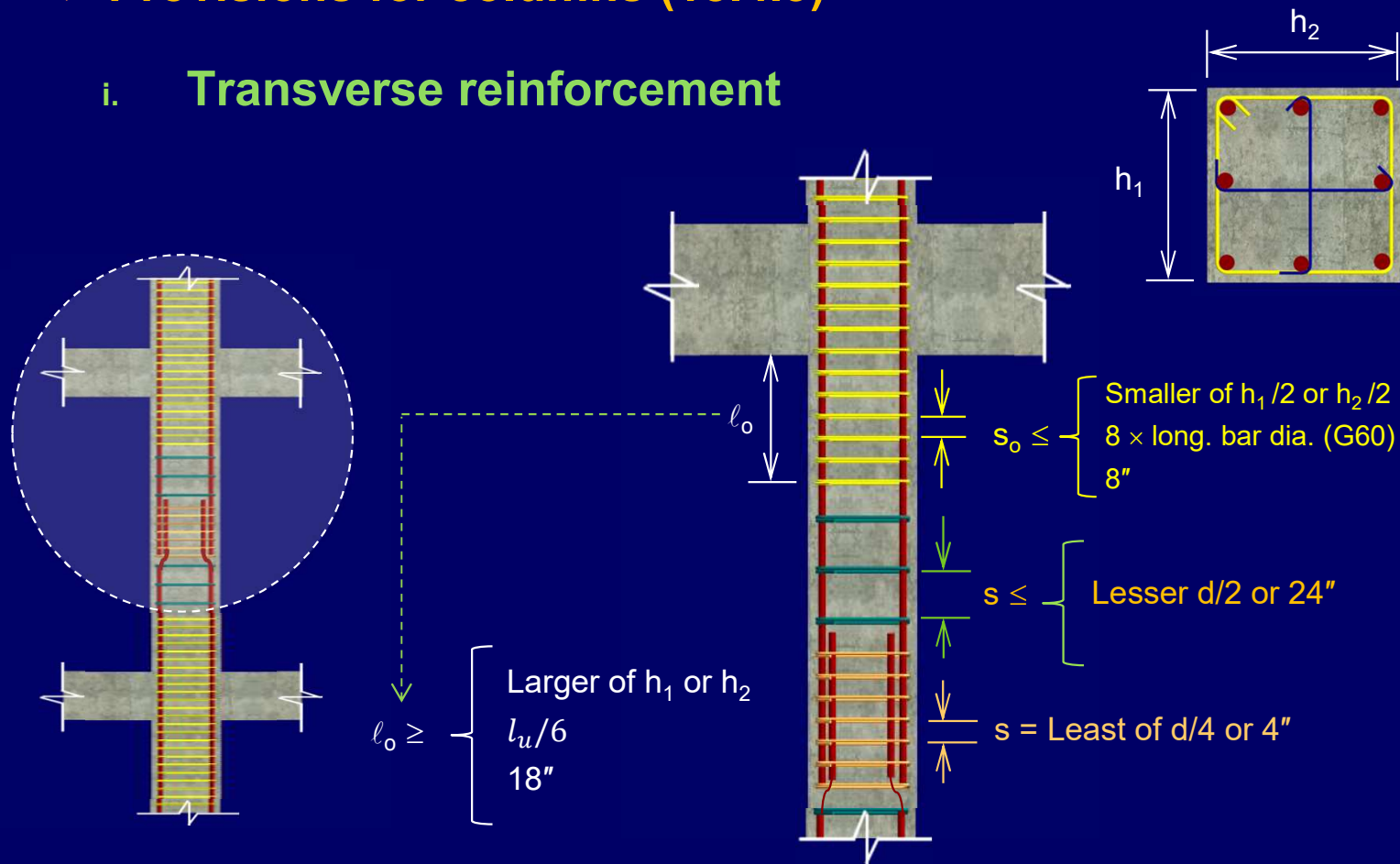



## Example 6.3

### □ Problem Statement

- A Reinforced concrete building is shown in figure 1 (a) on the next slide. All beams in the frame are 12" wide and 18" deep. All columns are 12" square.  $f_c' = 3$  ksi and  $f_y = 60$  ksi.

It is required only for frame **BFGC** to

- Provide** suitable number of bars in beams and columns for the reinforcement results shown in figure 1 (c), using only #5 bars as main reinforcement and #3 bars as transverse reinforcement.
- Provide** suitable spacing for stirrups and ties if shear reinforcement as per design is  $0.23 \text{ in}^2/\text{ft}$  in all parts of the frame.
- Satisfy** all SMF requirements for beams and columns.



## Example 6.3

### □ Problem Statement

- d) **Present** appropriately proportioned structural details of beam and column. Also draw the beam-column joint detail at detail X as shown in figure .



Figure 1 (a) : 3D RC Building



## Example 6.3

### □ Problem Statement



Figure 1 (b) : 3D RC Building Frame





## Example 6.3

### □ Problem Statement

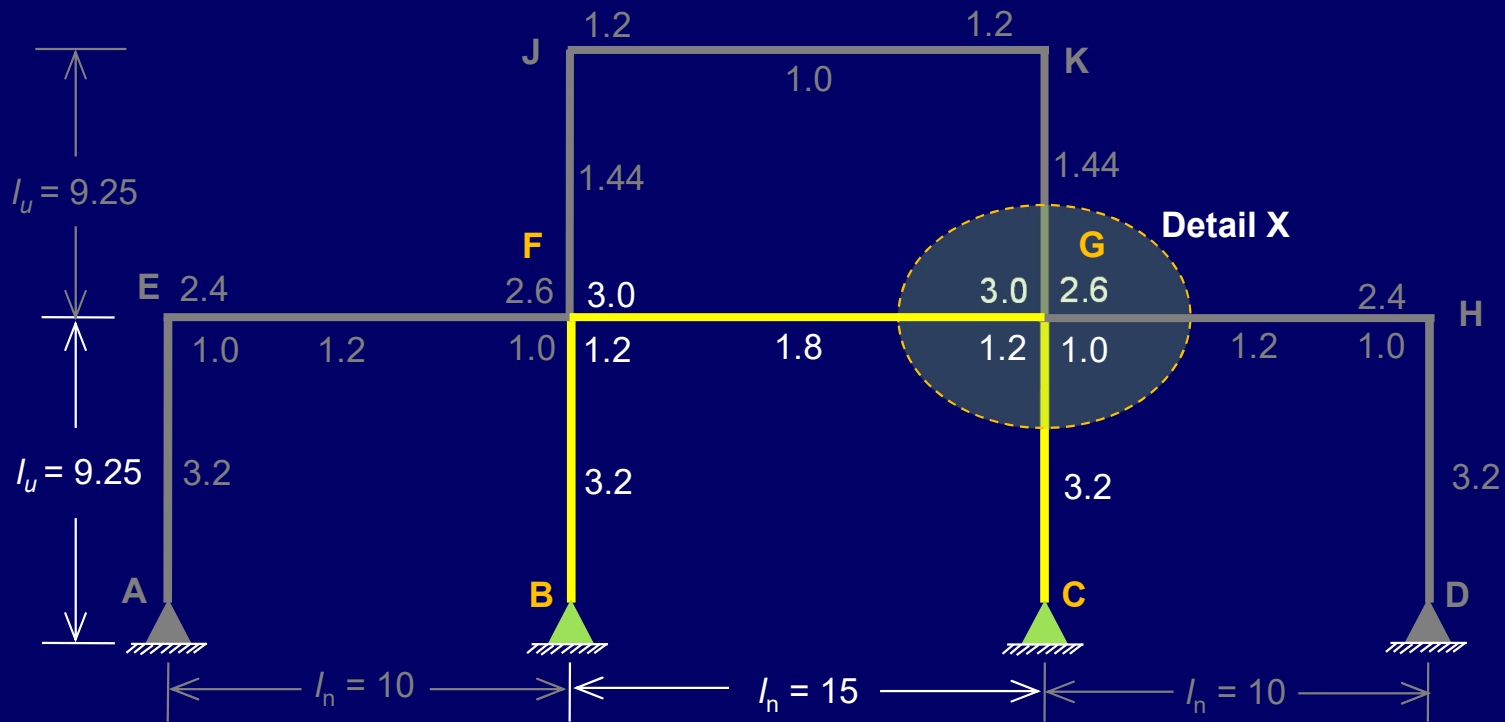

All reinforcement is in  $in^2$

All lengths are in feet

Figure 1 (c) : Reinforcement Details



## Example 6.3

### □ Solution

#### ▪ Part (a): Flexural reinforcement detailing

For the given beam FG, we have;

$$A_{s,min} = \frac{200}{60,000} \times 12 \times 15 = 0.6in^2$$

and

$$A_{s,max} = 0.025b_wd$$

$$= 0.025 \times 12 \times 15 = 4.5in^2$$

Provided  $A_s$  at top and bottom is within the limits → OK!

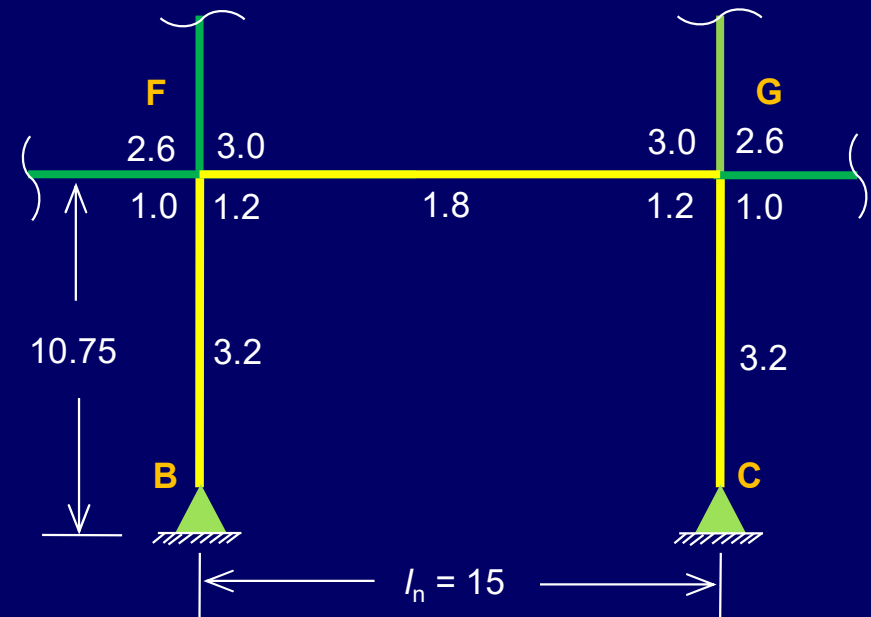



## Example 6.3

### □ Solution

#### ▪ Part (a): Flexural reinforcement detailing

For the given columns BF and CG, we have;

$$A_{s,min} = 0.01A_g$$

$$= 0.01 \times 12 \times 12 = 1.44in^2$$

and

$$A_{s,max} = 0.06A_g = 8.64in^2$$

Provided  $A_s$  of  $3.2in^2$  is within the limits  $\rightarrow OK!$

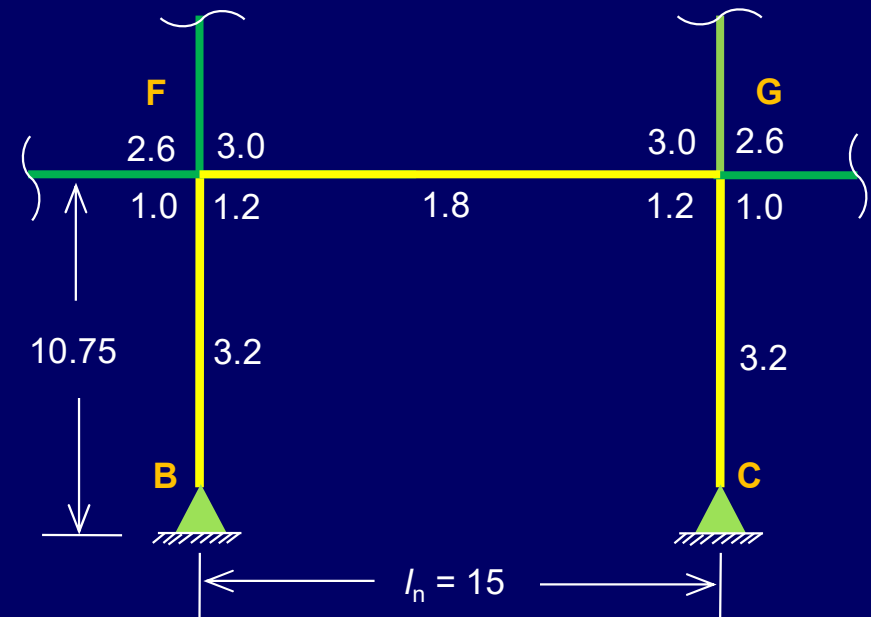



## Example 6.3

### □ Solution

#### ▪ Part (a): Flexural reinforcement detailing

Determine number of bars using #5 bars with  $A_b = 0.31 \text{ in}^2$

##### a. Beam Positive reinforcement

At midspan: No. of bars =  $1.8/0.31 \approx 6$  (provide in two layers, 4+2)

At ends: No. of bars =  $1.2/0.31 \approx 4$  (provide in single layer)

##### b. Beam Negative reinforcement (at joints)

No. of bars =  $3/0.31 \approx 10$  (provide in two layers, 5+5)

##### c. Column reinforcement

No. of bars =  $3.2/0.31 \approx 11$  (provide 12 bars for even distribution)



## Example 6.3

### □ Solution

- Part (a): Flexural reinforcement detailing

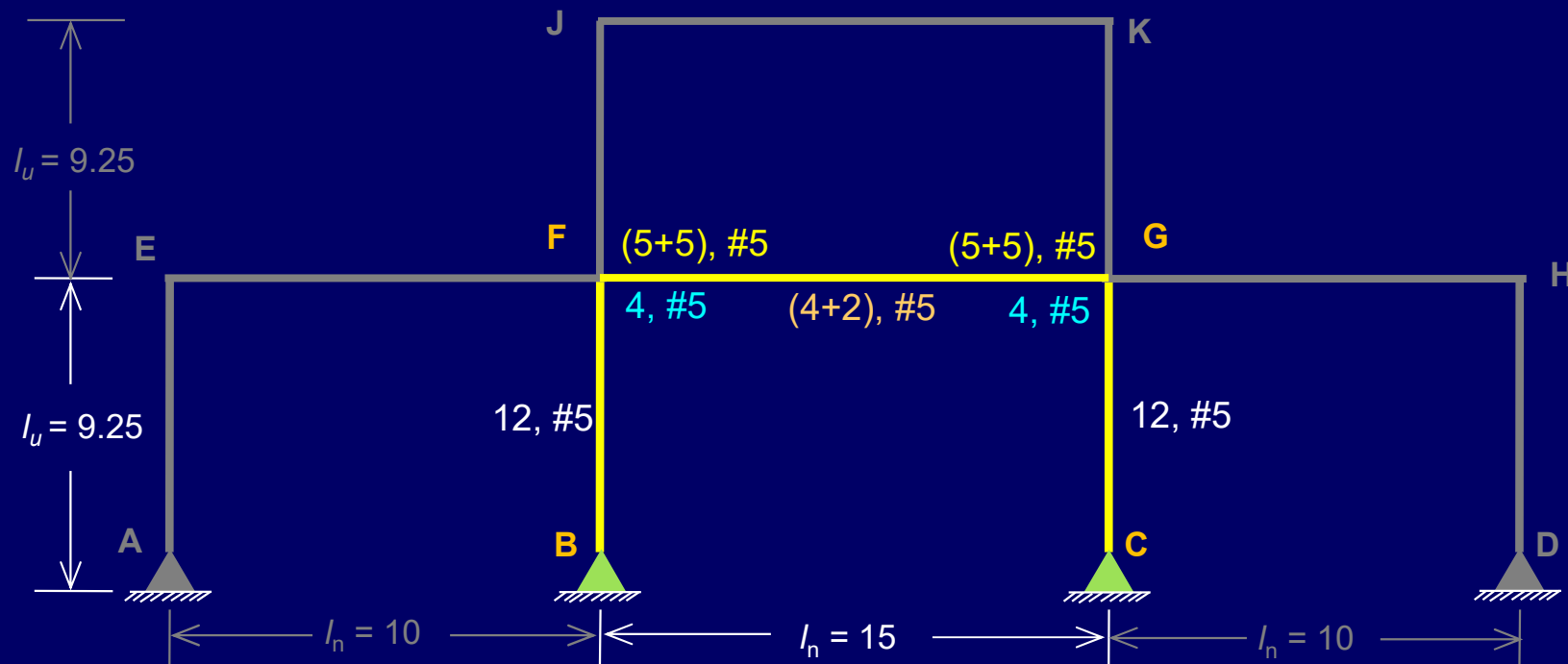



## Example 6.3

### □ Solution

#### ▪ Part (b): Shear reinforcement detailing

Determine spacing for transverse reinforcement #3 bars

##### a) Stirrup spacing for beam

$$S = \frac{12A_b}{A_s}$$

Using 2 legged #3 stirrups

$$S = \frac{12(0.22)}{0.23} = 11.5''$$

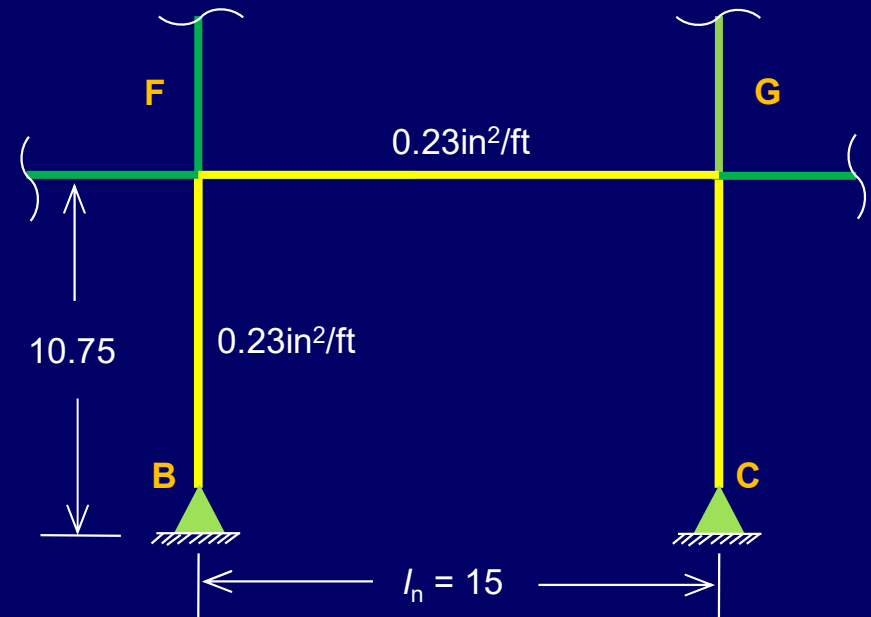



## Example 6.3

### □ Solution

#### ▪ Part (b): Shear reinforcement detailing

##### a) Stirrup spacing for beam

Maximum spacing  $S_{max}$  is given by

$$s_{max} = \text{Least of } \left\{ \begin{array}{l} \frac{A_v f_y}{50 b_w} = \frac{0.22 \times 60,000}{50 \times 12} = 14" \\ \frac{A_v f_y}{0.75 \sqrt{f_c'} b_w} = \frac{0.22 \times 60,000}{0.75 \sqrt{3000} \times 12} = 17.9" \\ \frac{d}{2} = \frac{15}{2} = 7.5" \\ 24" \end{array} \right. \quad s_{max} = 7.5" < S$$



## Example 6.3

### □ Solution

#### ▪ Part (b): Shear reinforcement detailing

##### b) Ties spacing for columns

$$S = \frac{12A_b}{A_s} = \frac{12(0.22)}{0.23} = 11.5''$$

Maximum spacing is given by

$$s_{max} = \text{Min. of } \left. \begin{array}{l} 16d_b \text{ (main bar)} = 16 \times 5/8 = 10'' \\ 48d_b \text{ (hoop/tie)} = 48 \times 3/8 = 18'' \\ \text{Least column dimension} = 12'' \end{array} \right\} s_{max} = 10'' < S$$

Finally, provide #3 @ 10" c/c





## Example 6.3

### □ Solution

- Part (b): Shear reinforcement detailing

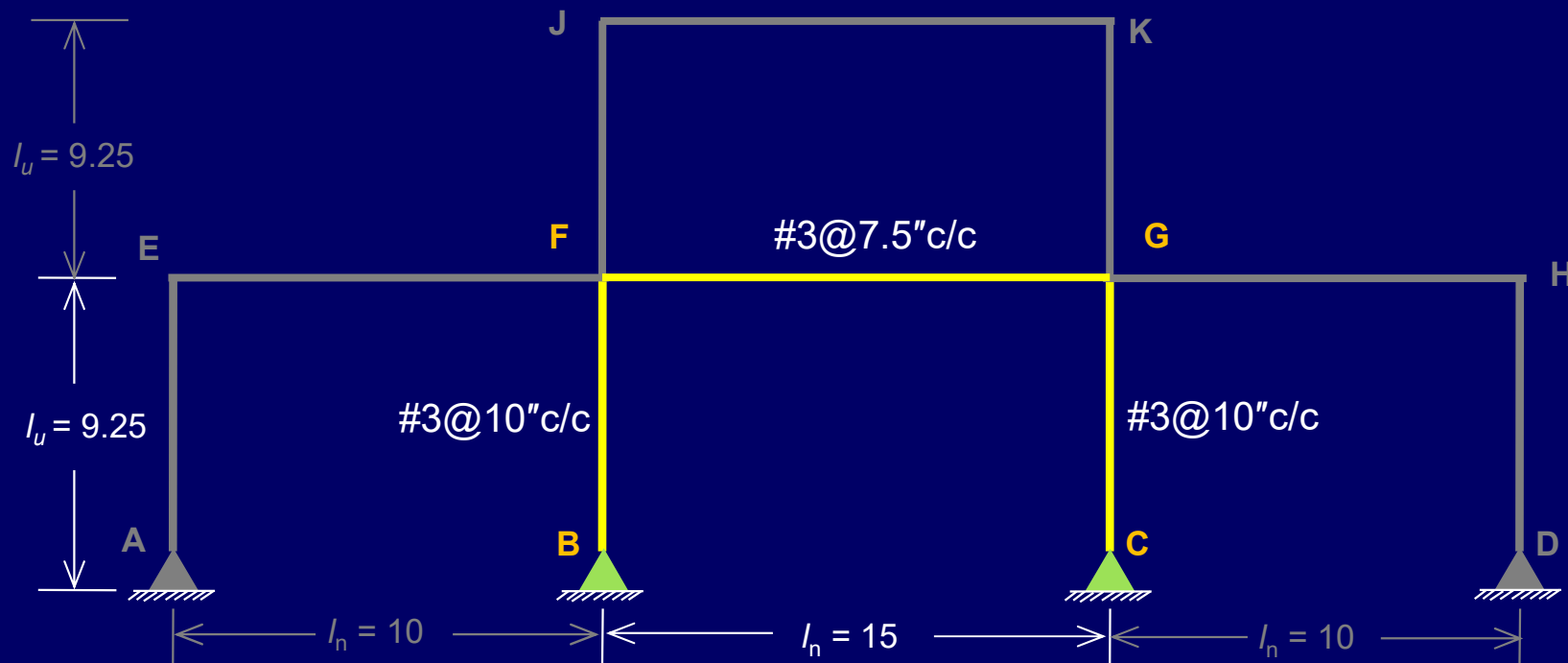



## Example 6.3

### □ Solution

#### ▪ Part (c): SMF requirements Checklist

##### a) Checklist for beams

##### i. Sizes

- $l_n/d = 15 \times 12/15 = 12 > 4 \rightarrow OK!$
- Width/ total depth =  $12/18 = 0.67 > 0.3 \rightarrow OK!$
- Width =  $12'' > 10'' \rightarrow OK!$
- Therefore 12" wide and 18" beams are OK.



## Example 6.3

### □ Solution

#### ▪ Part (c): SMF requirements Checklist

##### a) Checklist for beams

##### ii. Flexural reinforcement

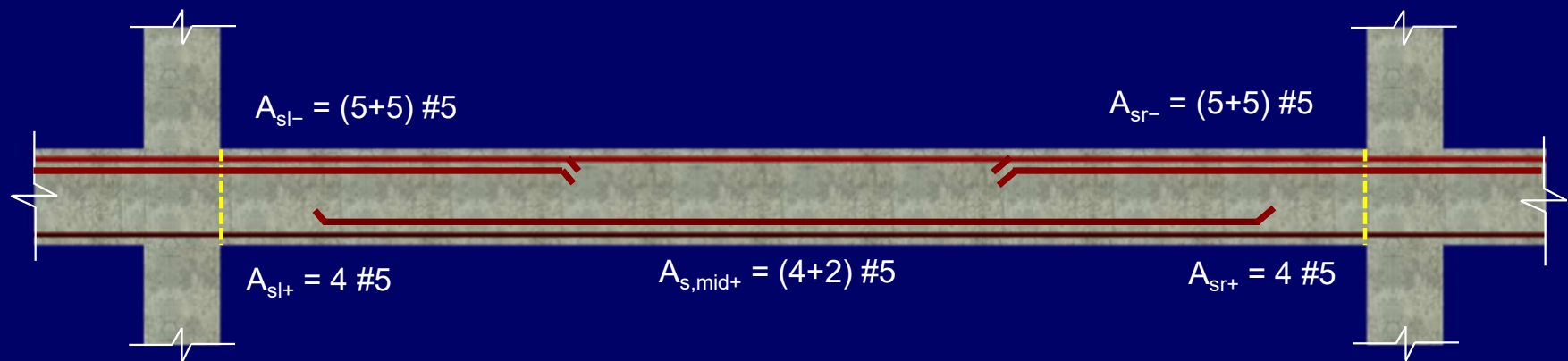

$A_{s+}$  (at joints)  $\geq \frac{1}{2} A_{s-}$  (at joints)  
 4 #5 bars are less than  $\frac{1}{2} \{(5+5) \#5 \text{ bars}\}$

$A_s$  (any section)  $\geq \frac{1}{4} \text{Max. } A_s \text{ at joints}$   
**Provide at least 3 bars**

**So, we must provide at least 5 bars at joint.**



# Example 6.3

## □ Solution

- **Part (c): SMF requirements Checklist**

- a) **Checklist for beams**

- **Recommended Flexural reinforcement**

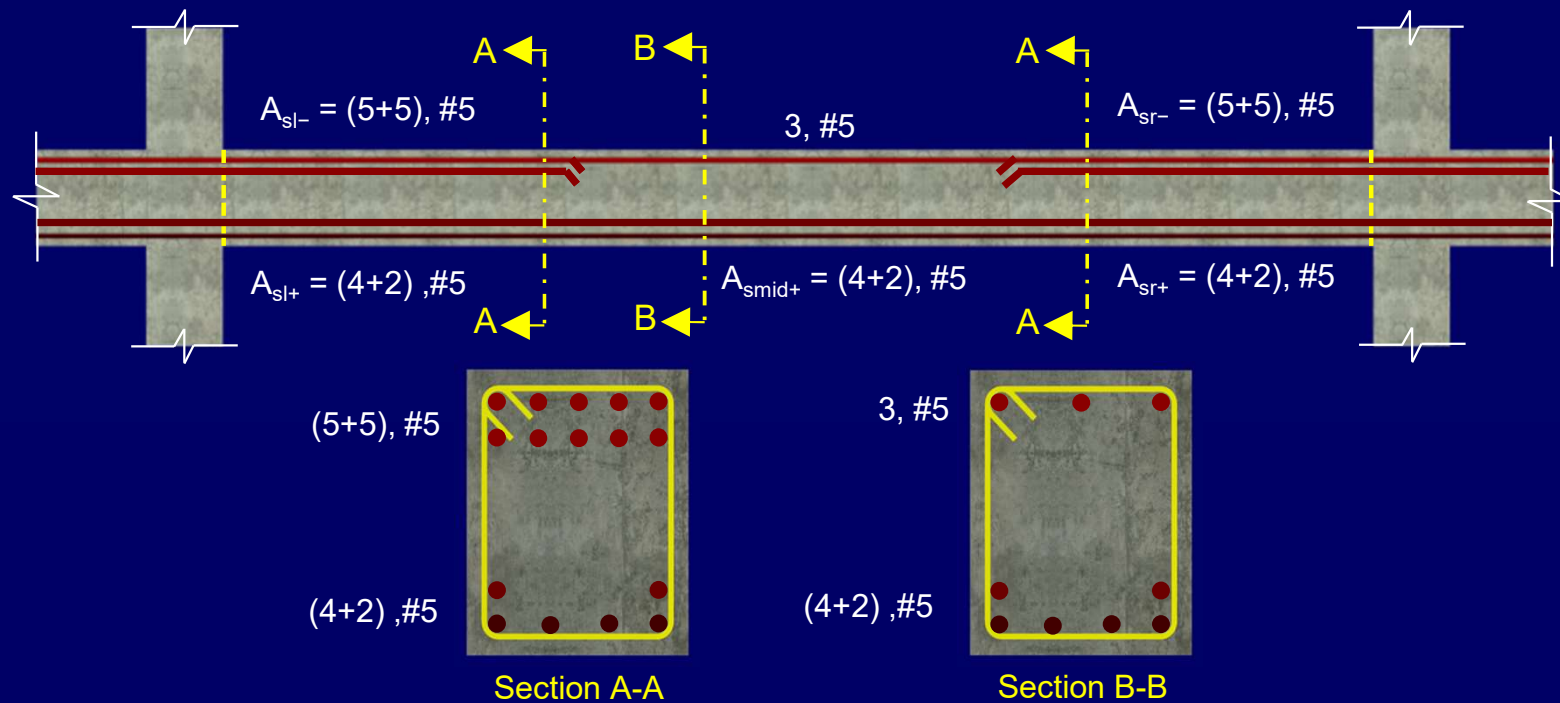



## Example 6.3

### □ Solution

#### ▪ Part (c): SMF requirements Checklist

##### a) Checklist for beams

##### iii. Transverse reinforcement

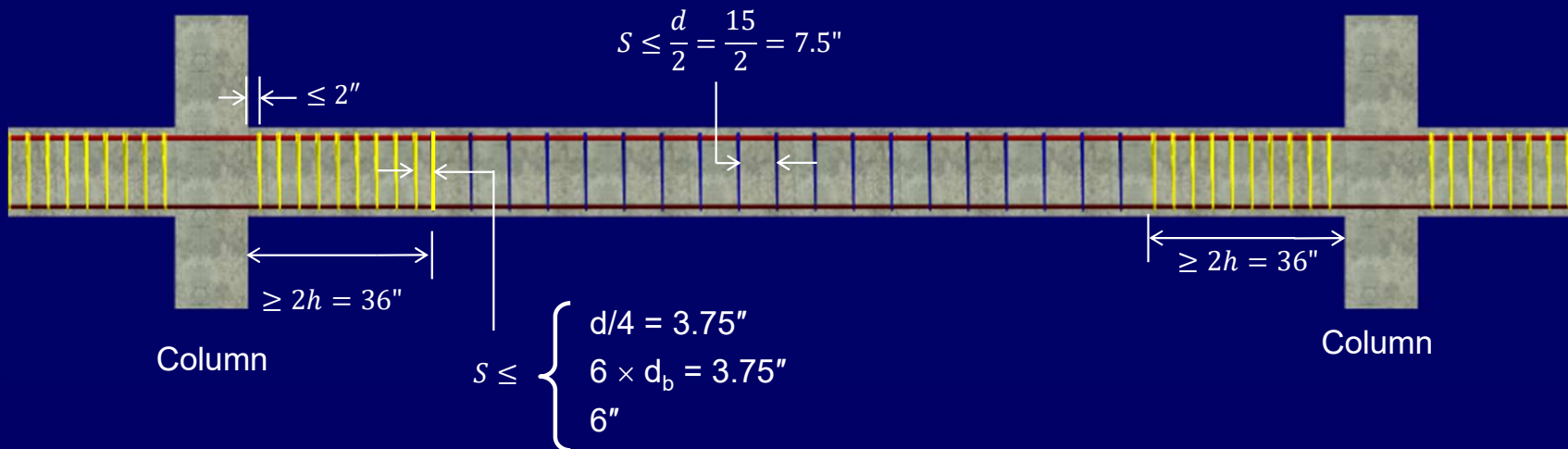



## Example 6.3

### □ Solution

#### ▪ Part (c): SMF requirements Checklist

##### a) Checklist for beams

##### iv. Lap splices (if required)

- Not to be provided within joints and  $2h$  region from face of the support.
- Spacing of hoops within lap = least of  $d/4$  or  $4''$  c/c =  $15/4=3.75$  or  $4''$  so  $3.75''$  c/c
- Lap splice length =  $70d_b = 70 (5/8) = 45''$

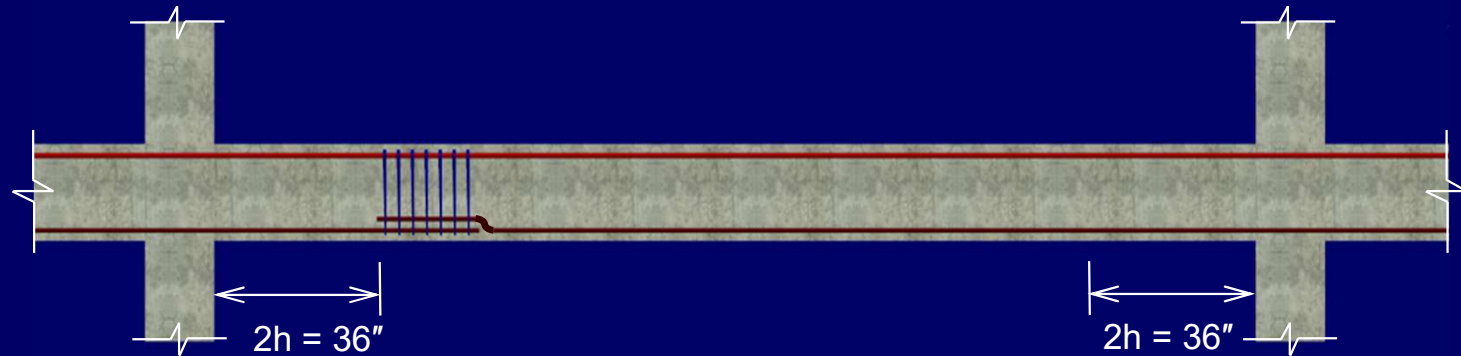



## Example 6.3

### □ Solution

#### ▪ Part (c): SMF requirements Checklist

##### b) Checklist for columns

##### i. Dimensional limits

- All columns are 12" square, which is equal to least required for SMF (i.e., 12").

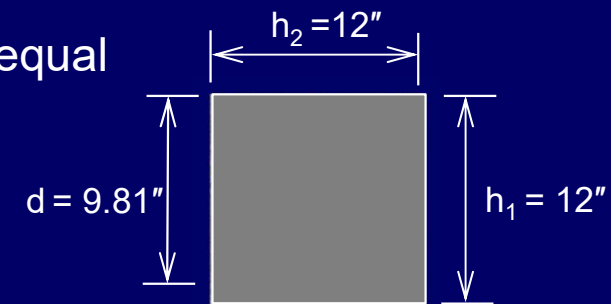

##### ii. Flexural Reinforcement

- All columns are reinforced with 12 #5 bars which gives  $\rho_g = 0.025$ , within the specified range  $0.01 \leq \rho_g \leq 0.06$ .



## Example 6.3

### □ Solution

#### ▪ Part (c): SMF requirements Checklist

##### b) Checklist for columns

##### iii. Transverse reinforcement

$l_o$  is maximum of

- Max larger column dimension = 12"
- $l_u/6 = (9.25 \times 12)/6 = 18.5''$
- 18"

Spacing of ties in  $l_o$  region is least of

- Smaller column dimension/4 =  $12/4 = 3''$
- $6 \times \text{long bar dia} = 6 \times (5/8) = 3.75''$

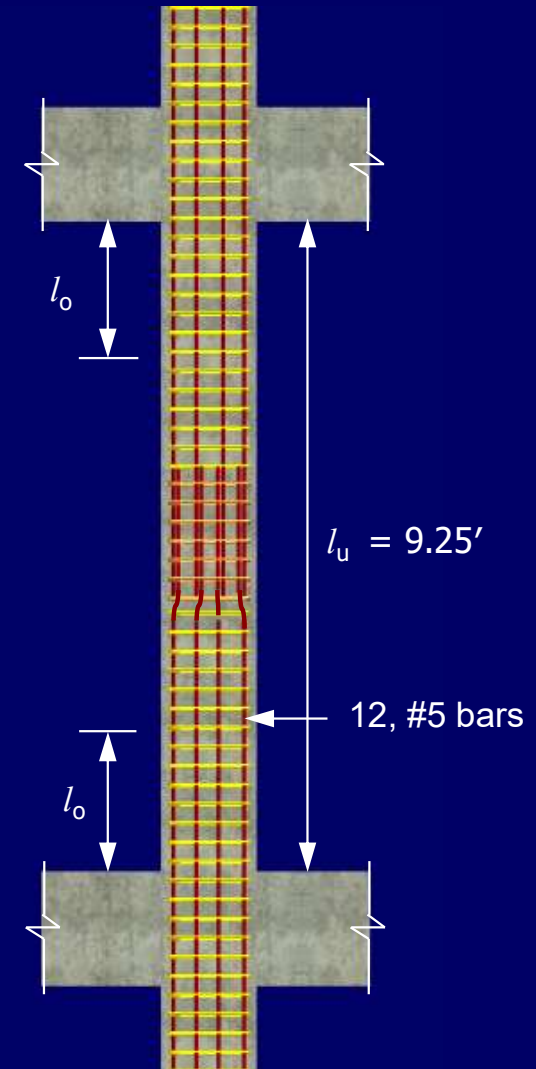





## Example 6.3

### □ Solution

#### ▪ Part (c): SMF requirements Checklist

##### b) Checklist for columns

##### iii. Transverse reinforcement

Spacing other than  $l_o$  region will be least of

- $6 \times \text{long bar dia} = 6 \times (5/8) = 3.75''$
- $6''$

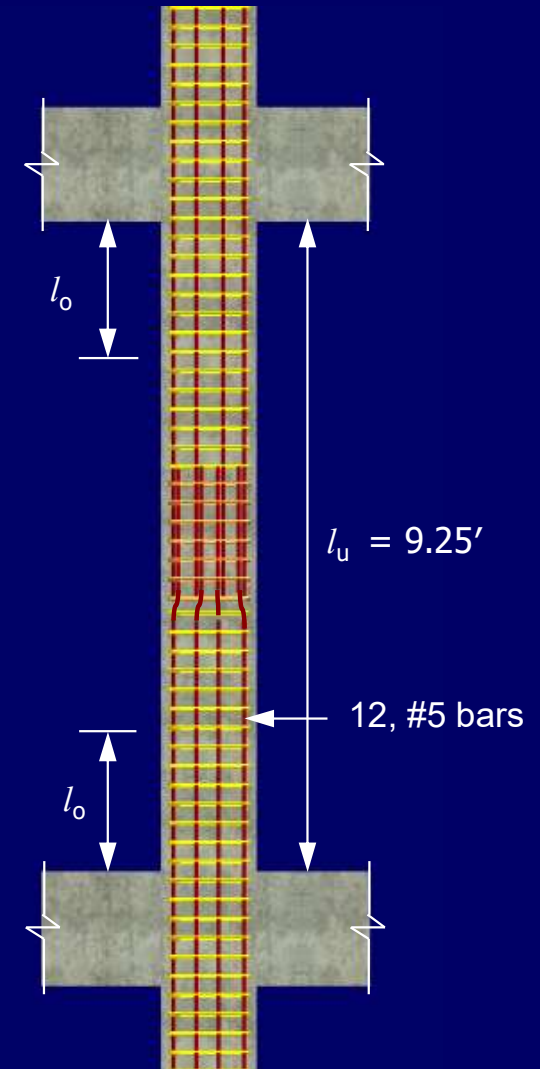



## Example 6.3

### □ Solution

#### ▪ Part (c): SMF requirements Checklist

##### b) Checklist for columns

##### iv. Lap splice

Spacing within lap splice is given by;

$$S = \text{least of } \frac{d}{4} \text{ or } 4'' = \frac{9.81}{4} = 2.45''$$

$$\text{Lap splice length} = 1.3 \times 0.05 (f_y / \sqrt{f_c'}) d_b$$

After putting values;

$$\text{Lap splice length} \approx 45'' = 3.75'$$

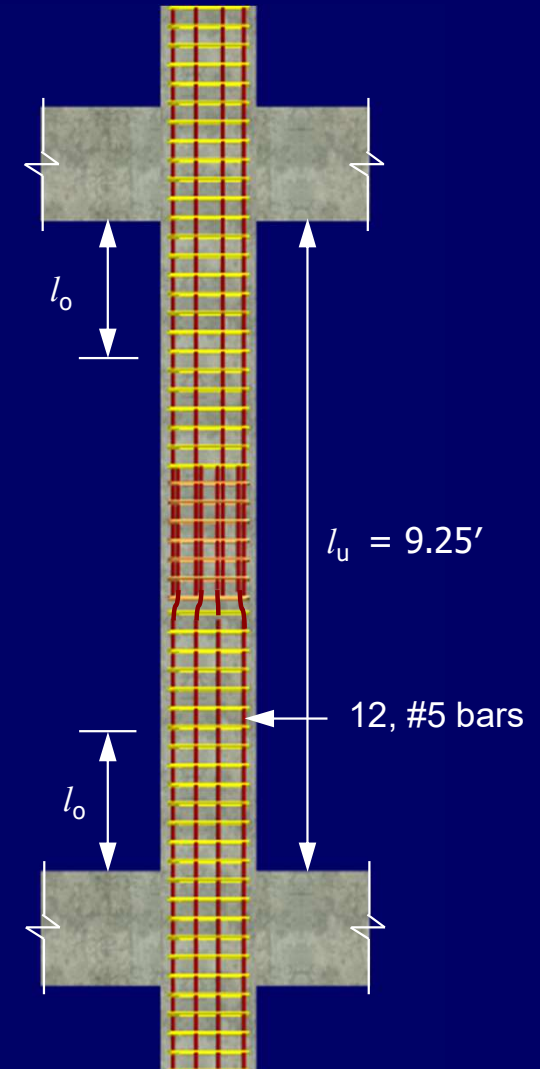



## Example 6.3

### □ Solution

#### ▪ Part (c): SMF requirements Checklist

##### c) Checklist for Joints

- The column dimension parallel to the beam reinforcement must be at least 20 times the diameter of the largest longitudinal bar for Grade 60 steel and normal weight concrete.
  - $20 \times 5/8 = 12.5" > 12" \rightarrow$  change size of column
  - Take column dimension parallel to beam long bar = 13.5"



## Example 6.3

### □ Solution

#### ▪ Part (c): SMF requirements Checklist

##### c) Checklist for Joints

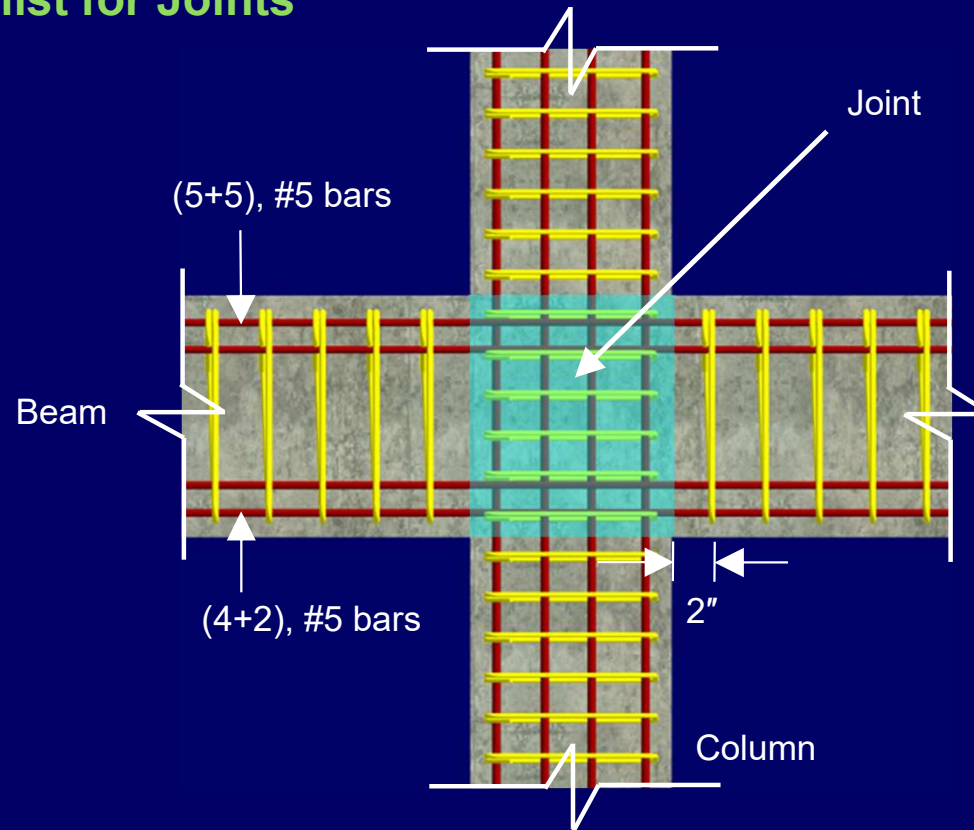



## Example 6.3

### □ Solution

#### ▪ Part (d): Presentation of structural details

- In this part, structural drawings showing all calculated SMF details have been asked to draw. This has already been done in part (c) along with each member (beam and column) SMF checks.
- However, in the examination, it is better to draw all drawings here in part (d) at the same place to avoid waste of time.



## Example 6.3

### □ Solution

#### ▪ Part (d): Presentation of structural details

##### a) Beam details

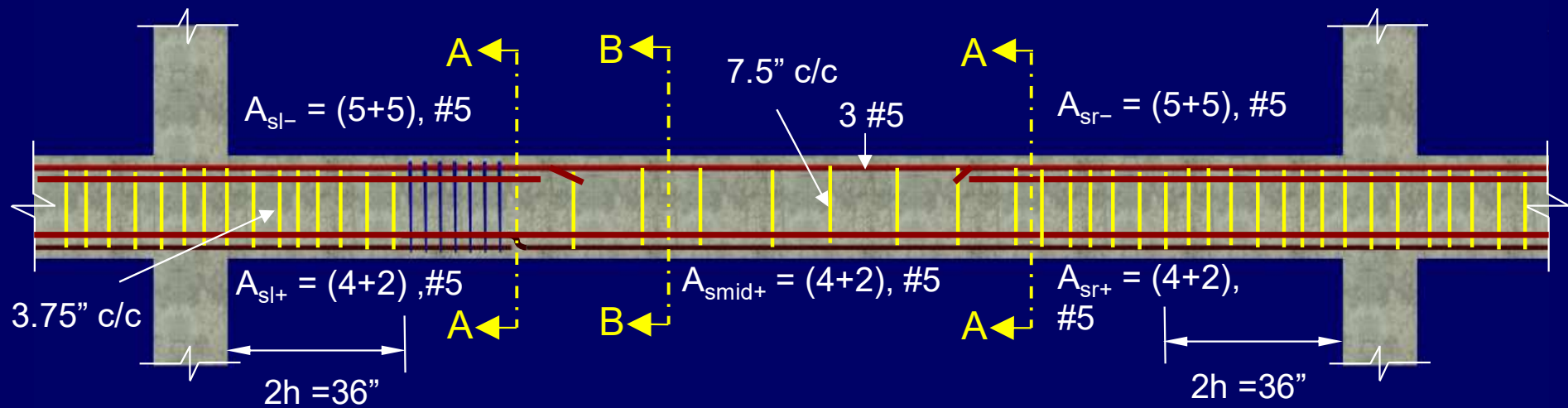



## Example 6.3

### □ Solution

- Part (d): Presentation of structural details

#### a) Beam details

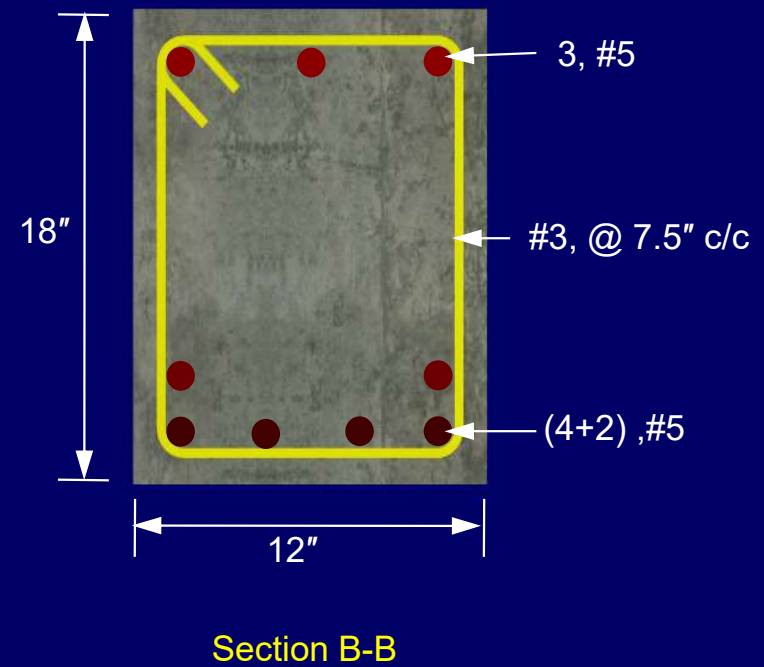
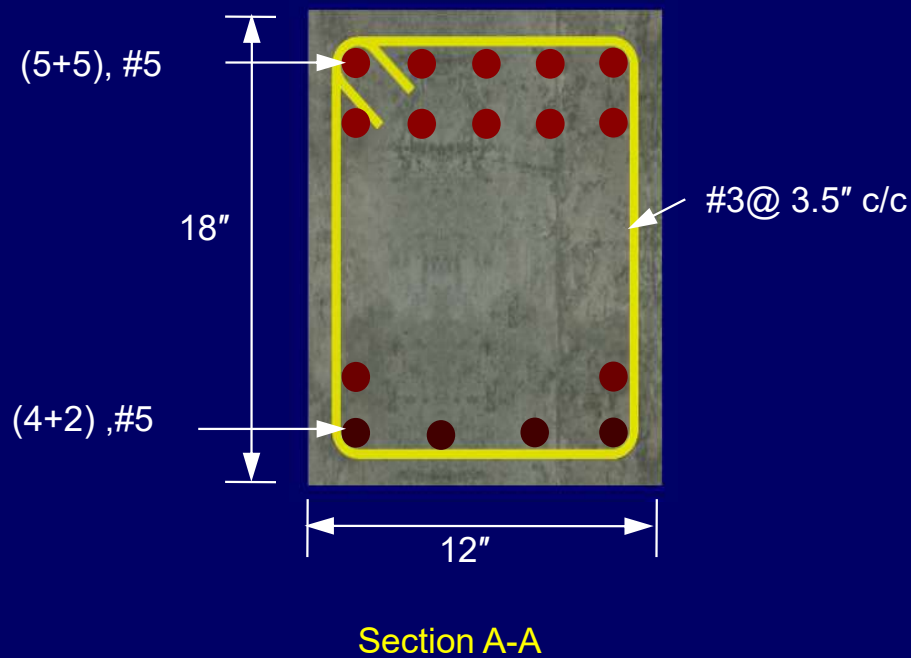



# Example 6.3

## □ Solution

- Part (d): Presentation of structural details

### b) Column details

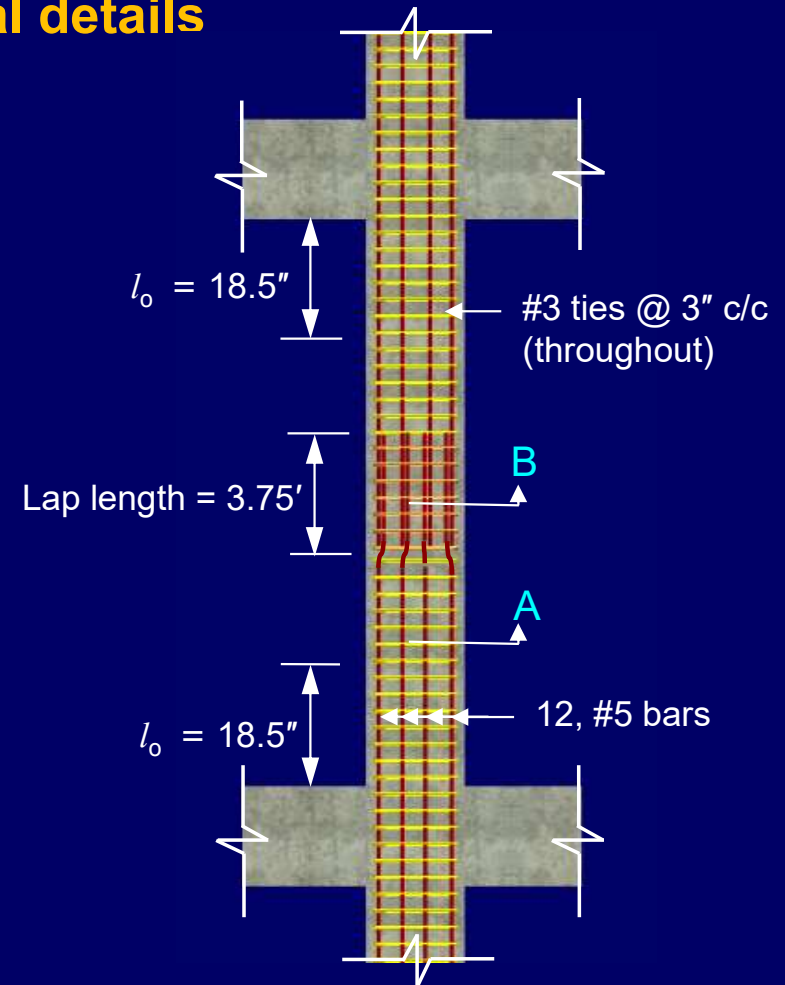
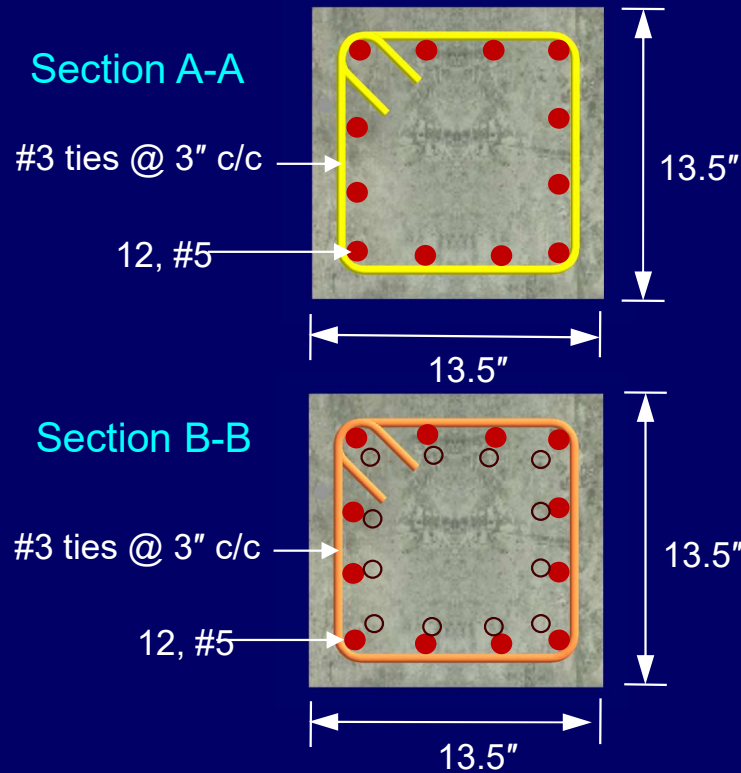





## Example 6.3

### □ Solution

#### ▪ Part (d): Presentation of structural details

##### c) Joint details

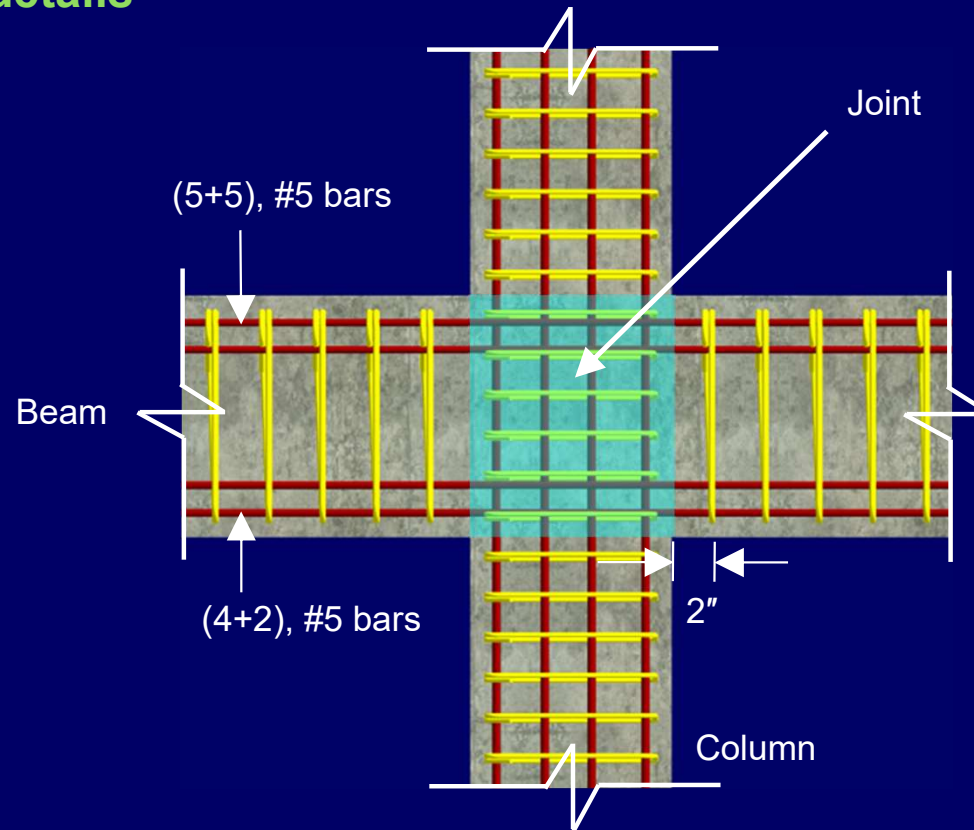



# References

- Design of Concrete Structures 14th / 15th edition by Nilson, Darwin and Dolan.
- Building Code Requirements for Structural Concrete (ACI 318-19)

