



بِسْمِ اللَّهِ الرَّحْمَنِ الرَّحِيمِ

CE-5115

Advance Design of Reinforced Concrete Structures

By:

Prof. Dr. Qaisar Ali

Civil Engineering Department

UET Peshawar

drqaisarali@uetpeshawar.edu.pk

www.drqaisarali.com



Grading Policy

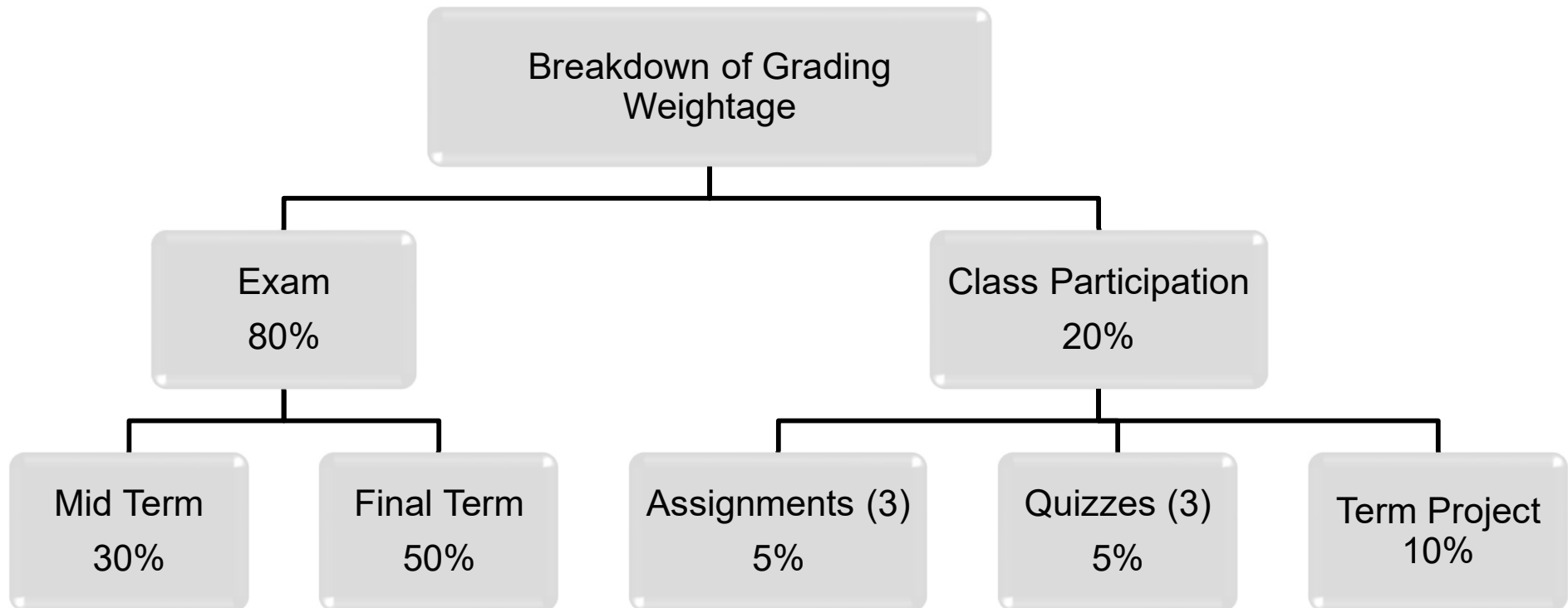

NOTE:

- Attendance of 75 % is must to pass the course.
- Final term exam will also include the course taught before midterm exam.



Teaching Plan

Week	Lectures	Assessments
01	Lecture 01_Introduction to Advance Design of Reinforced Concrete Structures	
02	Lecture 02_Materials	
03	Lecture 03 Part-I_Design of RC Members for Flexure and Axial Loads	Assignment #1
04	Lecture 03 Part-II_Design of RC Members for Flexure and Axial Loads	
05	Lecture 04_Design of RC Members for Shear and Torsion	Quiz #1
06	Lecture 05_Serviceability Requirements & Development of Reinforcement	
07	Lecture 06_Design of Reinforced Concrete Slabs	Assignment #2
Mid Term Examination		



Teaching Plan

Week	Lectures	Assessments
08	Lecture 07_Idealized Structural Modeling of RC Structures	
09	Lecture 08_Analysis of Reinforced Concrete Structures	Quiz #2
10	Lecture 09_Introduction to Earthquake Resistant Design of RC Structures	
11	Lecture 10_Design of Beam-Column Connections in Monolithic RC Structures	Assignment #2
12	Lecture 11_Slenderness Effects in RC Structures	
13	Lecture 12_Design of RC Shallow Foundations	Quiz #3
14	Term Presentations	
Final Term Examination		



Lecture Availability

- You can access previous versions of lectures on my website at the following link :

[https://drqaisarali.com/lectures/.](https://drqaisarali.com/lectures/)

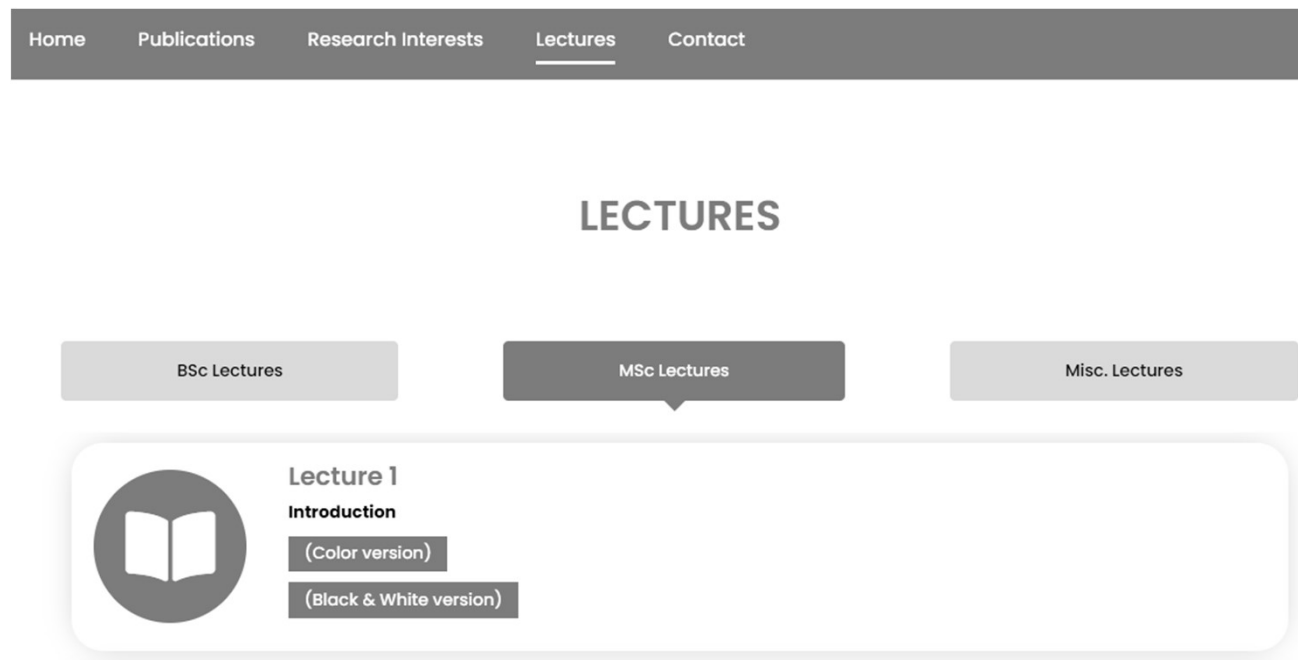

- Updated lectures upon completion will be uploaded on website as well as on Google Classroom.



Lecture 01

Introduction

By:

Prof. Dr. Qaisar Ali

Civil Engineering Department

UET Peshawar

drqaisarali@uetpeshawar.edu.pk

<https://drqaisarali.com>



Learning Outcomes

- **At the end of this lecture, students will be able to;**
 - **Explain** the historical development of cement and reinforced concrete and the significance of building codes, including the ACI Code.
 - **Classify** concrete structural systems.
 - **Recognize** limit states and basic design relationships.
 - **Illustrate** the concept of structural safety by employing probabilistic computations, considering load considerations, and implementing strength reduction factors.
 - **Understand** ACI Code's design procedure and adhere to customary dimensions and construction tolerances.



Lecture Contents

- Historical Development of Cement and Reinforced Concrete
- Building Codes and the ACI Code
- The Design Process and Design Team
- Concrete Floor Systems
- Limit States
- Design Approach
- Probabilistic Calculation of FOS
- Design Procedure of the ACI Code
- References



Historical Development of Cement and Reinforced Concrete

□ Cement

- In 1824, Joseph Aspdin mixed limestone and clay and heated them in a kiln to produce cement.
- The commercial production started around 1880.





Historical Development of Cement and Reinforced Concrete

□ Reinforced Concrete

- Joseph Monier, owner of a French nursery garden began experimenting (in around 1850) on reinforced concrete tubs with iron for planting trees.
- The first RC building in the US was a house built in 1875 by W. E. Ward, a mechanical engineer.
- Working Stress Design Method, developed by Coignet in around 1894 was universally used till 1950.

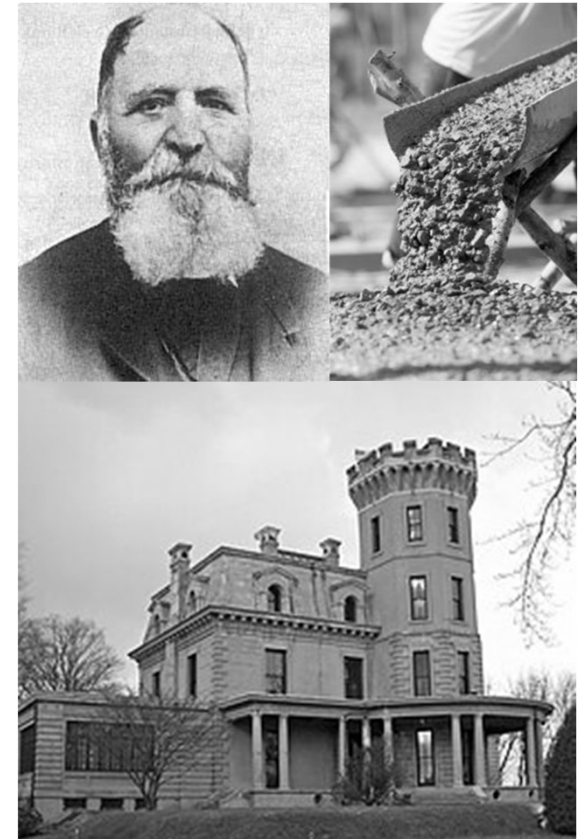



Historical Development of Cement and Reinforced Concrete

□ Historical Evolution of Concrete

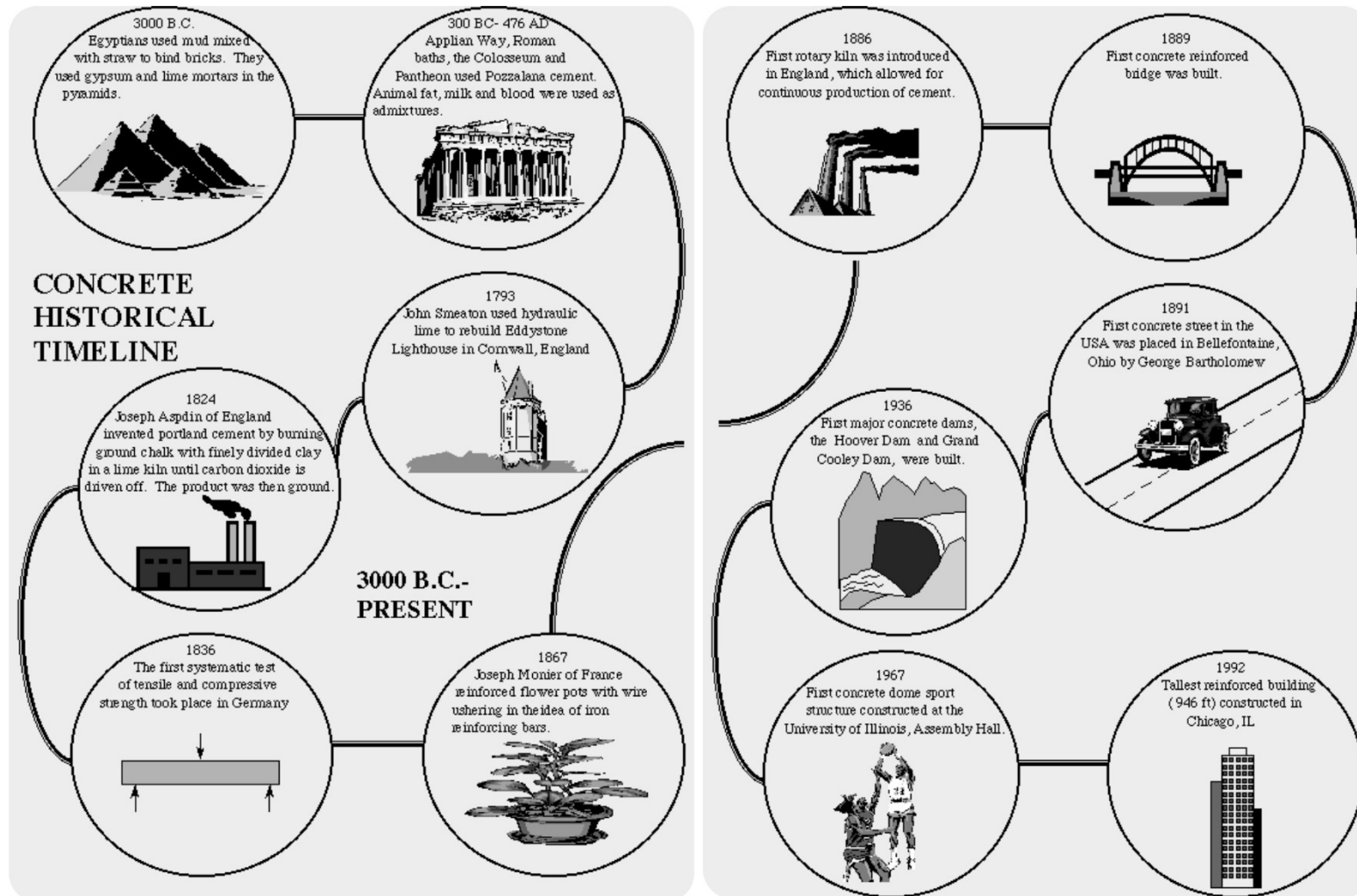



Building Codes and the ACI Code

□ General Building Codes

- Cover all aspects of building design and construction from architecture to structural to mechanical and electrical etc. UBC, IBC and Euro-code are general building codes.

□ Seismic Codes

- Cover only seismic provisions of buildings such as SEAOC and NEHRP of USA, BCP-SP 07 of Pakistan.



Building Codes and the ACI Code

❑ Material Specific Codes

- Cover design and construction of structures using a specific material or type of structure such as ACI, AISC, AASHTO etc.

❑ Other Codes Such as ASCE

- Cover minimum design load requirement, Minimum Design Loads for Buildings and other Structures (ASCE 7-16).



Building Codes and the ACI Code

□ New Building Design Codes

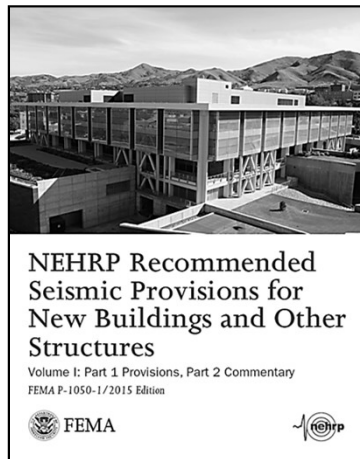

FEMA P-1050



UBC 97

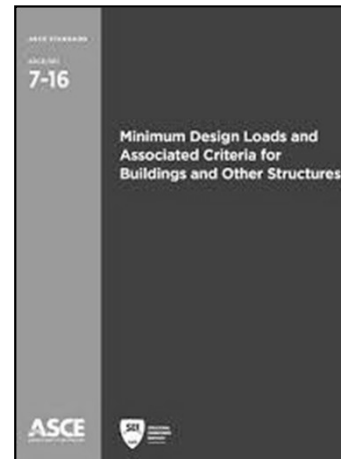

ASCE 7



IBC

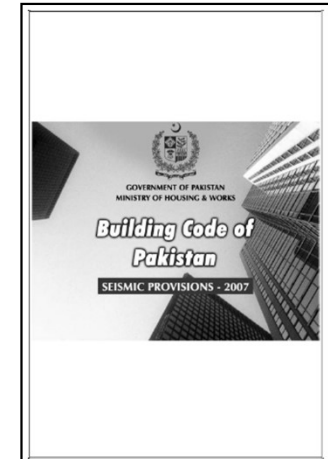

BCP SP 07



Building Codes and the ACI Code

□ Existing Buildings Design/Evaluation Codes

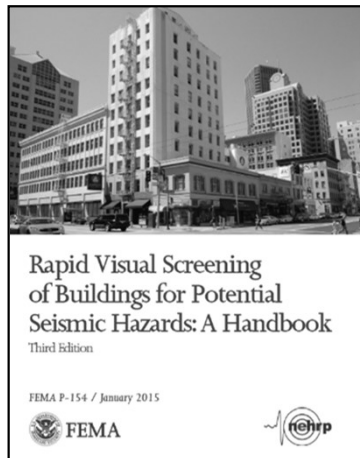

FEMA P-154

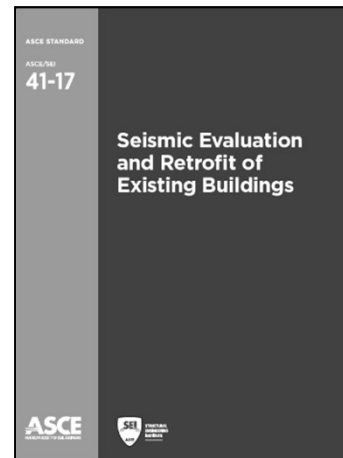

ASCE 41



IEBC

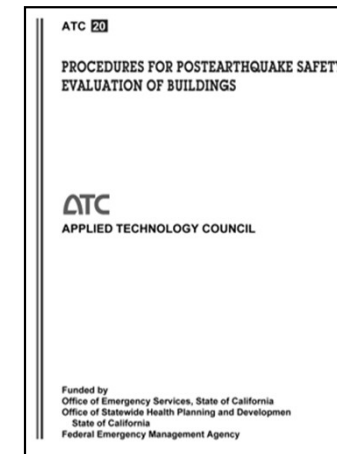

ATC 20



Building Codes and the ACI Code

□ General Building Codes in USA

- *The National Building Code (NBC)*
 - Published by the Building Officials and Code Administrators International, was used primarily in the northeastern states.
- *The Standard Building Code (SBC)*
 - Published by the Southern Building Code Congress International, was used primarily in the southeastern states.
- *The Uniform Building Code (UBC)*
 - Published by the International Conference of Building Officials, was used mainly in the central and western United States.



Building Codes and the ACI Code

□ General Building Codes in USA

- *The International Building Code (IBC)*
 - Published by International Code Council ICC for the first time in 2000, revised every three years.
 - The IBC has been developed to form a consensus single code for USA.
 - Currently IBC 2021 is available.
 - UBC 97 is the last UBC code and is still existing but will not be updated. Similarly, NBC, SBC will also be not updated.



Building Codes and the ACI Code

□ Seismic Codes in USA

- *National Earthquake Hazards Reduction Program (NEHRP)*
 - Recommended Provisions for the Development of Seismic Regulations for New Buildings developed by FEMA (Federal Emergency Management Agency).
 - The NBC, SBC and IBC have adopted NEHRP for seismic design.
- *Structural Engineers Association of California (SEAOC)*
 - Its seismic provisions are based on the Recommended Lateral Force Requirements and Commentary (the SEAOC “Blue Book”) published by the Seismology Committee of SEAOC.
 - The UBC has adopted SEAOC for seismic design



Building Codes and the ACI Code

□ Building Code of Pakistan

- Building Code of Pakistan, Seismic Provision BCP SP-07 has adopted the seismic provisions of UBC 97 for seismic design of buildings.
- IBC 2000 could not be adopted that time because some basic input data required by IBC for seismic design did not exist in Pakistan.
- However, in 2022, BCP SP-07 was replaced by BCP-2021, which has now adopted IBC 2021.



Building Codes and the ACI Code

□ The ACI MCP

- ACI MCP (American Concrete Institute Manual of Concrete Practice) contains 150 ACI committee reports; revised every three years.
 - ACI 318: Building Code Requirements for Structural Concrete.
 - ACI 315: The ACI Detailing Manual.
 - ACI 349: Code Requirement for Nuclear Safety Related Concrete Structures.
 - Many others.



Building Codes and the ACI Code

□ The ACI 318 Code

- The American Concrete Institute “*Building Code Requirements for Structural Concrete (ACI 318)*,” referred to as the ACI code, provides minimum requirements for structural concrete design or construction.
- The term “structural concrete” is used to refer to all plain or reinforced concrete used for structural purposes.
- Prestressed concrete is included under the definition of reinforced concrete.

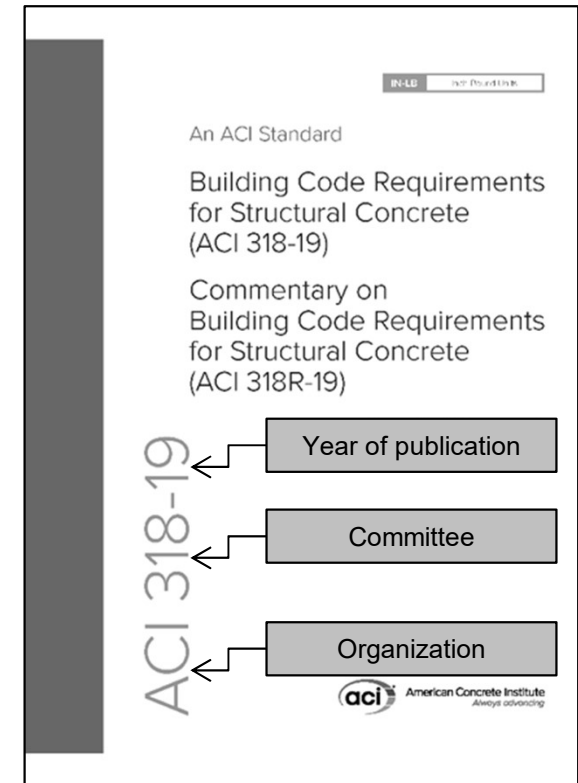

[Brief visit to the Code >>](#)



Building Codes and the ACI Code

□ The ACI 318 Code

- The ACI 318 code has no legal status unless adopted by a state or local jurisdiction.
- It is also recognized that when the ACI code is made part of a legally adopted general building code, that general building code may modify some provisions of ACI 318 to reflect local conditions and requirements.



Building Codes and the ACI Code

□ The Compatibility Issue in BCP SP-2007

- Building Code of Pakistan, Seismic Provision BCP SP-07 has adopted the seismic provisions of UBC 97 for seismic design of buildings.
- As the UBC 97 has reproduced ACI 318-95 in Chapter 19 on concrete, the load combinations and strength reduction factors of ACI 318-02 and later codes are not compatible with UBC 97 and hence BCP SP-07. Therefore ACI 318-02 and later codes cannot be used directly for design of a system analyzed according to the seismic provisions of UBC 97.



Building Codes and the ACI Code

□ The Compatibility Issue in BCP SP-2007

- To resolve this issue, BCP SP-2007 recommends using ACI 318-05 code for design except that load combinations and strength reduction factors are to be used as per UBC 97.
- The IBC adopts the latest ACI code by reference whenever it is revised and hence are fully compatible.
- However, the compatibility issue has been rectified in BCP-2021, which now aligns entirely with ACI 318 Code.



The Design Process and the Design Team

□ General

- The design covers all aspects of structure, not only the structural design.
- The structural engineer is a member of a team whose members work together to design a building, bridge, or any other structure.



The Design Process and the Design Team

□ Liaison between Engineer and Architect

- Close cooperation with the architect in the early stages of a project is essential in developing a structure that not only meets the functional and aesthetic requirements but exploits to the fullest the special advantages of reinforced concrete.



The Design Process and the Design Team

□ Objectives of Design

- The four major objectives of design are:

1. Appropriateness

- Functionality, to suit the requirements
- Aesthetics, to suit the environment

2. Economy

- The overall cost of the structure should not exceed the client's budget.

3. Structural adequacy (safety)

- Strength
- Serviceability

4. Maintainability

- The structure should be simple so that it can be maintained easily.



The Design Process and the Design Team

□ Major Phases of Design

1. The client's needs and priorities
2. Development of project concept
3. Design of Individual systems



Concrete Floor Systems

□ Selection Criterion

- Depending on structural spans, loading conditions, purpose of building, availability of formwork, skilled labor and material etc., several different structural systems such as flat plate, flat slab, one-way or two-way joist system etc. are possible.



Concrete Floor Systems

□ Various Types of Concrete Floor System

1. Flat Plate

- A concrete floor directly supported on columns (with no beams) is called flat plate.
- Flat plates are economical for
 - Short and medium spans (15 ft – 25 ft).
 - Moderate live loads.
- Punching shear is a typical problem in flat plates.

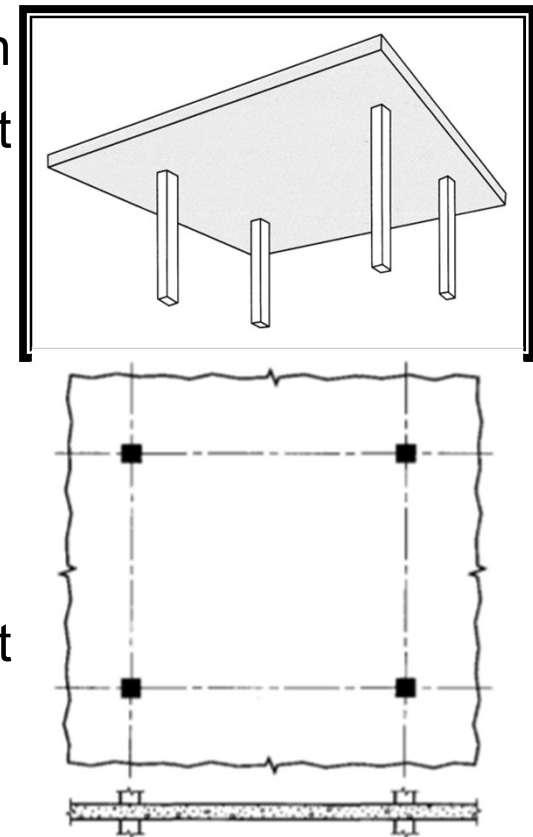



Concrete Floor Systems

□ Various Types of Concrete Floor System

2. Flat Slab

- A flat plate with column capital ^[1] or drop panel ^[2] is referred to as a flat slab.
- Economical range: 20 ft. – 30 ft.
- The drop panel and column capital are intended to reduce the punching shear problem.

[1] Drop panel is a projection of slab at the vicinity of column.

[2] Column capital is a widening of the top of a support column where it meets the soffit of a slab.

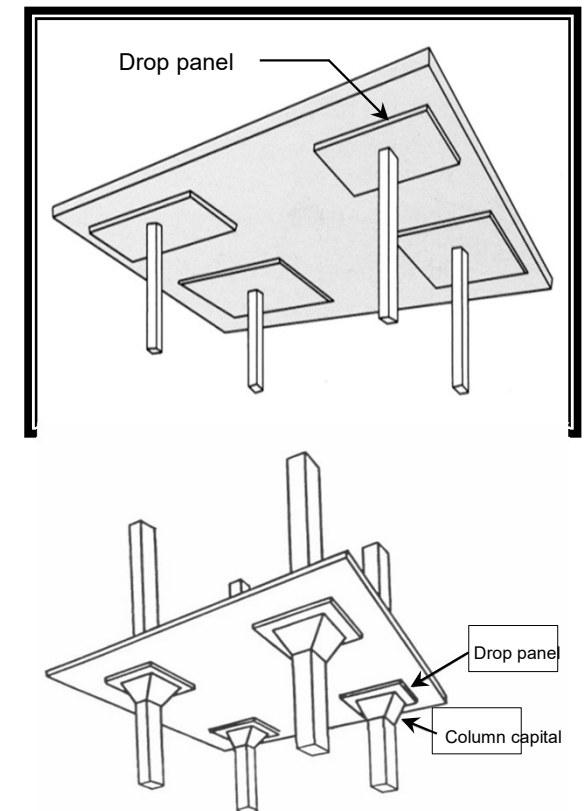



Concrete Floor Systems

□ Various Types of Concrete Floor System

3. One-way Joist System

- Joist construction consists of a monolithic combination of regularly spaced ribs with clear spacing of 3' and a top slab arranged to span in one direction or two orthogonal directions.
- Long spans, economic range: 30 ft. – 50 ft.

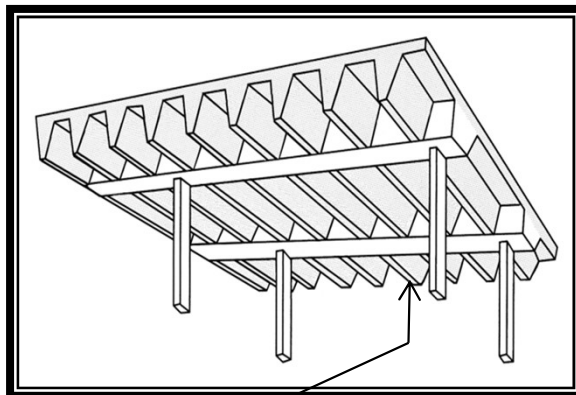

RIB

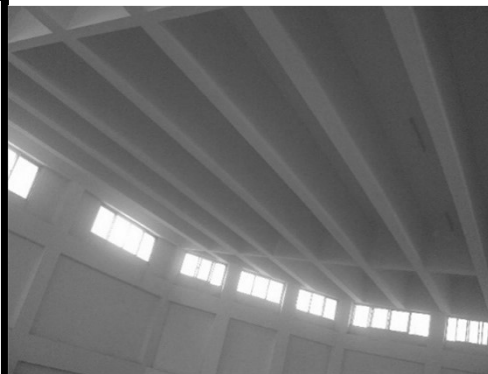

Peshawar University Auditorium





Concrete Floor Systems

□ Various Types of Concrete Floor System

4. Two-way Joist System

- A two-way joist system, or waffle slab, comprises evenly spaced concrete joists spanning in both directions and a reinforced concrete slab cast integrally with the joists.
- Like one-way joist system, a two-way system will be called as two-way joist system if clear spacing between ribs (dome width) does not exceed 30 inches.



Concrete Floor Systems

□ Various Types of Concrete Floor System

4. Two-way Joist System



Jamia Darul Uloom Haqqania, Akora Khattak

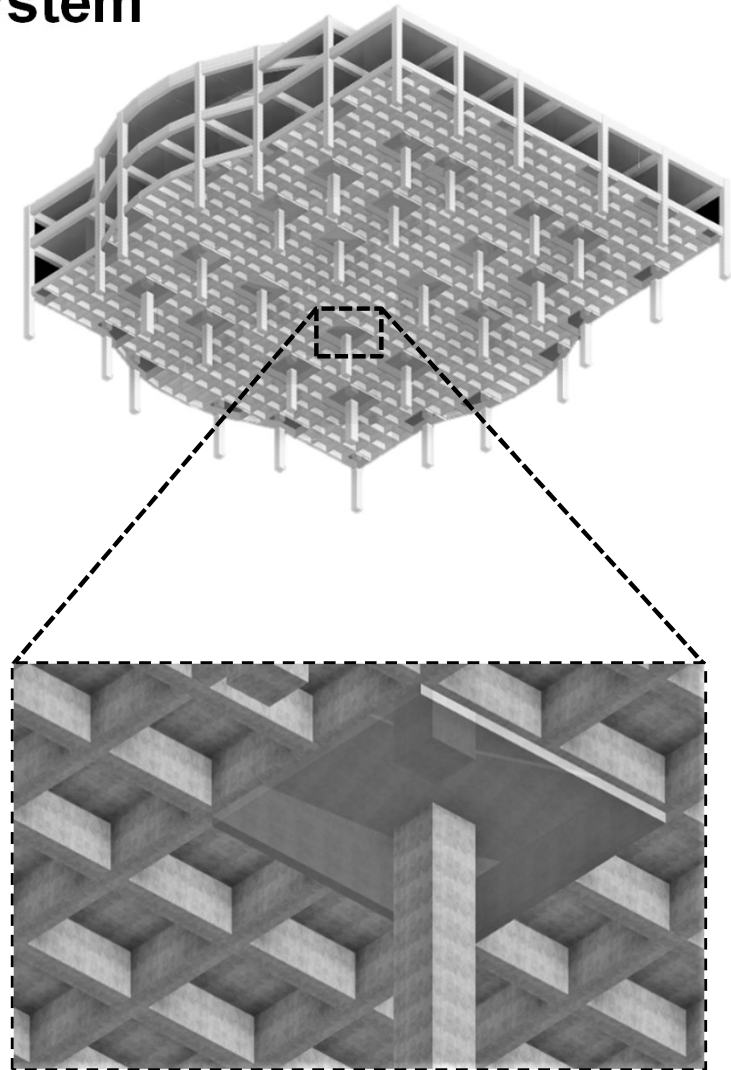



Concrete Floor Systems

□ Various Types of Concrete Floor System

5. Beam-supported Slab Systems

- Slab supported on beams on two opposite sides, or on all four sides is known as beam-supported slab system.
- Suitable for long spans (up to 30 ft.) and intermediate and heavy loads.
- Based on the behavior of bending, these slabs may be One – way slab or Two – way slab.

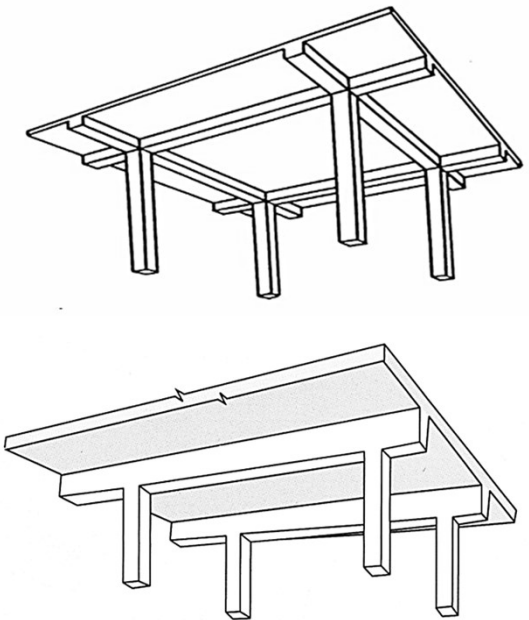



Concrete Floor Systems

□ Various Types of Concrete Floor System

6. Beam-and-Girder Floors

- A beam and girder floor consists of a series of parallel beams supported at their extremities by girders, which in turn frame into concrete columns placed at regular intervals over entire floor area.
- Adapted to any loads and spans. Normal range of column spacing is 16 to 32 ft.

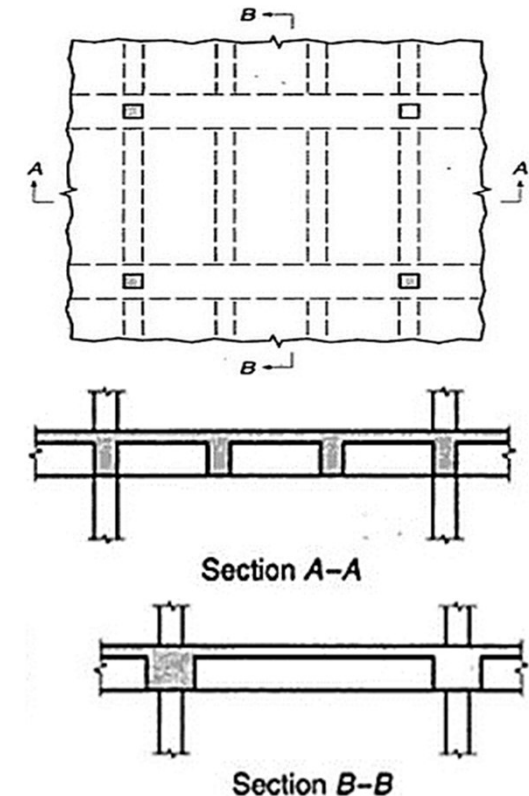



Concrete Floor Systems

□ Various Types of Concrete Floor System

7. Banded-slab System

- For light loads, a floor system has been developed in which the beams are omitted in one direction, the one-way slab being carried directly by column line beams that are very broad and shallow.
- These beams, supported directly by the columns, become little more than a thickened portion of the slab.
- This type of construction is known as banded slab construction.

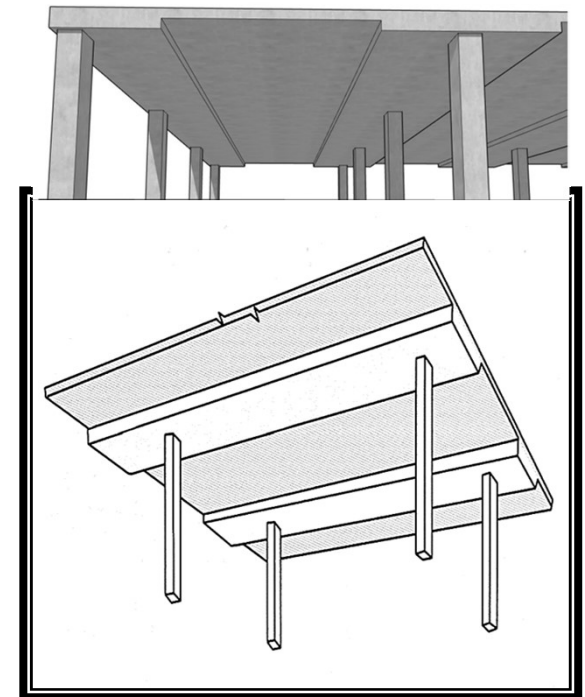



Concrete Floor Systems

□ Various Types of Concrete Floor System

8. Composite Slab

- In this system, columns, beams, and girders consist of structural steel whereas the floors are reinforced concrete slabs.
- The spacing of beams is usually 6 to 8 ft.

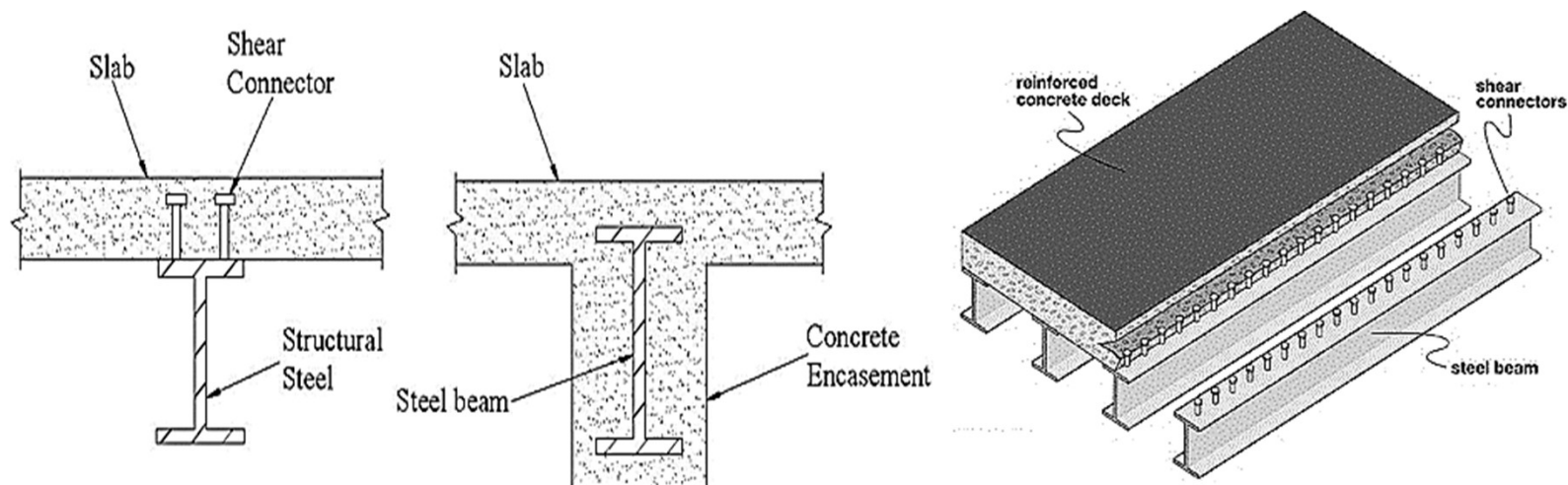



Concrete Floor Systems

□ Various Types of Concrete Floor System

9. Steel Deck RC Slab

- In this structural system, the steel deck serves as stay in place form and, with suitable detailing the slab becomes composite with the steel deck, serving as the main tensile flexural steel.
- The spacing of beams is usually 12 ft.

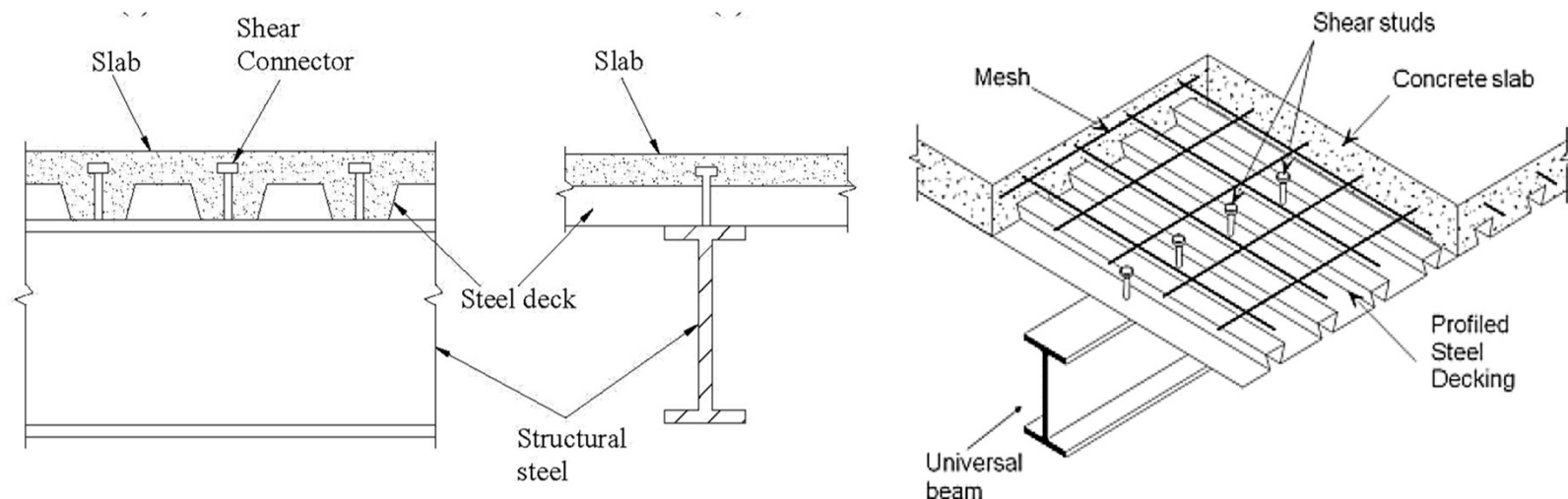



Concrete Floor Systems

□ Various Types of Concrete Floor System

10. Post-tensioned Slab

- In the post-tensioned slab systems, hollow conduits are provided in slab through which the tendons are placed. Tendons are tensioned after the concrete has gained its strength. Columns and beams are regular reinforced concrete members.
- Longer spans can be achieved due to pre-stress, which can be used to counteract deflections.

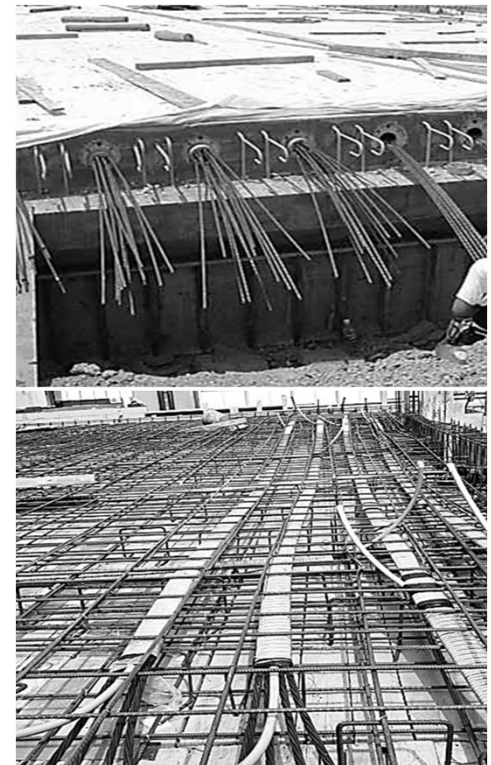



Concrete Floor Systems

□ Various Types of Concrete Floor System

11. Precast Slab

- It consists of either precast concrete arched panels, hollow mini-slabs, or planks that are placed between smaller, more frequently spaced precast beams or joists that are spanning between walls or columns.





Limit States

□ Definition

- A limit state is a condition (limit) of a structure beyond which it ceases to serve its intended purpose.
- Limit state method of design is based on different limit states
 - i. Ultimate Limit State**
 - ii. Serviceability Limit State**
 - iii. Special Limit State**



Limit States

1. Ultimate Limit State

- This consists of rupture or collapse of a part of or whole structure..
- Such a limit state should have a very low probability of occurrence, since it may lead to loss of life and major financial losses.



Limit States

1. Ultimate Limit State

- Major ultimate limit states are:



Loss of Equilibrium
(Tipping or Sliding)

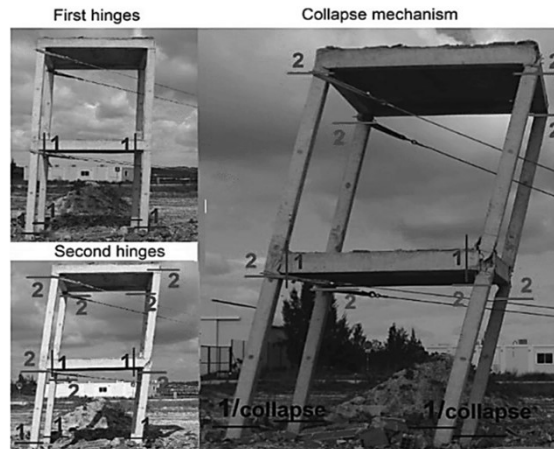

Plastic Mechanism
(Rebars yield to form plastic hinges)



Instability
(Due to deformations e.g., Buckling)



Limit States

1. Ultimate Limit State

- Major ultimate limit states are:

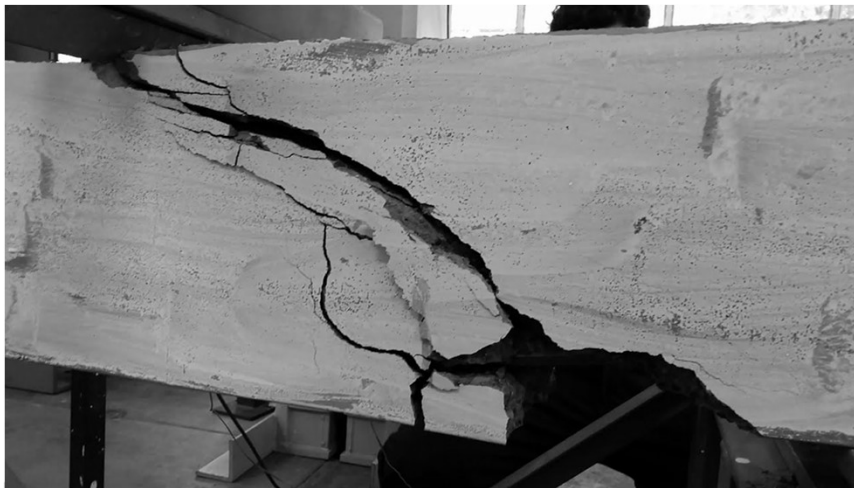

Rupture
(Flexure, shear or combination)



Fatigue
(Failure due to repetitive cyclic loading)



Limit States

1. Ultimate Limit State

- Major ultimate limit states are:

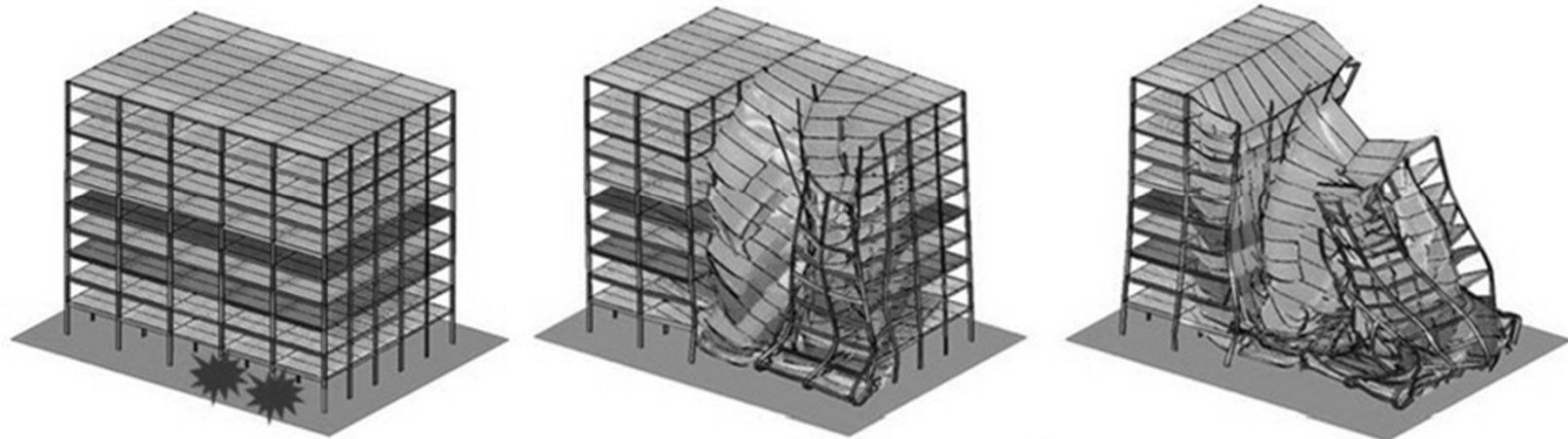

Progressive Collapse Mechanism
(Failure of structural members one after another)



Limit States

2. Serviceability Limit State

- These involve disruption of the functional use of the structure, but not collapse.
- Since there is less danger of loss of life, a higher probability of occurrences can generally be tolerated than in the case of an ultimate limit state.
- Examples of serviceability limit state are:
 - Excessive deflections
 - Undesirable vibrations
 - Excessive cracking etc.



Limit States

3. Special Limit State

- This class of limit state involves damage or failure due to abnormal conditions or abnormal loadings.
- Special limit state include:
 - Damage or collapse in extreme earthquakes.
 - Structural effects of fire, explosions, or vehicular collisions



Limit States

□ Limit States and Design of RC Buildings

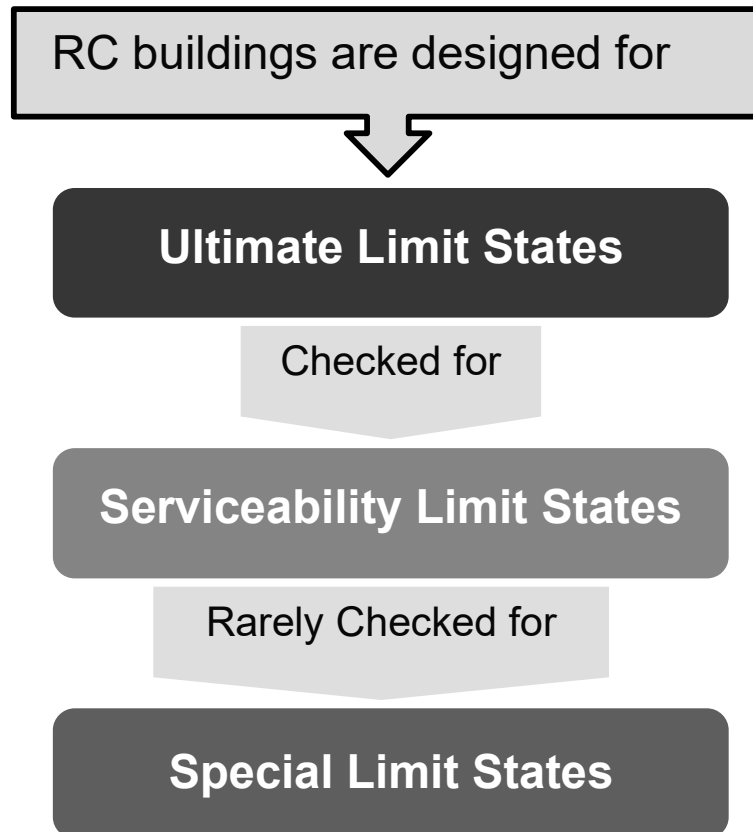

Note: SLS and not ULS may be governing limit states for retaining structures and other structures where deflection and crack control are important.



Design Approach

□ Concept of Demand and Capacity

- **Demand:** Demand refers to all external actions that act on a structure.
- **Capacity:** Capacity is the overall resistance of structure to carry imposed demand.
- **Load Effects:** The internal changes produced in a structure due to demand are called load effects.
- Bending, torsion, shear, axial forces, deflection, vibration etc. are the example of load effects.



Design Approach

□ Basic Design Relationship

- A successful structural design should ensure that the structure's **Capacity** exceeds **Demand** with an appropriate margin of safety (factor of safety) to meet the conditions of safety, serviceability, economy, and functionality.
- Capacity < Demand ⇒ Failure
- Capacity > Demand ⇒ Success with FOS
- Capacity = Demand ⇒ Success without FOS

What is "Factor of Safety" and why should we incorporate it in design?



Design Approach

□ Factor of Safety (FOS)

- Factor of Safety (FOS) is the margin by which the capacity of a structure or its component exceeds the applied demand.
- There are two main reasons due to which safety factors, such as load and resistance factors, are necessary in structural design.
 1. Variability in Resistance (capacity)
 2. Variability in Loads (demand)



Design Approach

□ Factor of Safety (FOS)

1. Variability in Resistance

- The figure on the right shows Comparison of measured (M_{test}) and computed (M_n) failure moments for 112 similar RC beams.
- The difference in measured and calculated failure moments is mainly due to variations in
 - Specified and Actual Strength of materials
 - Specified and actual dimensions
 - Simplifying assumptions

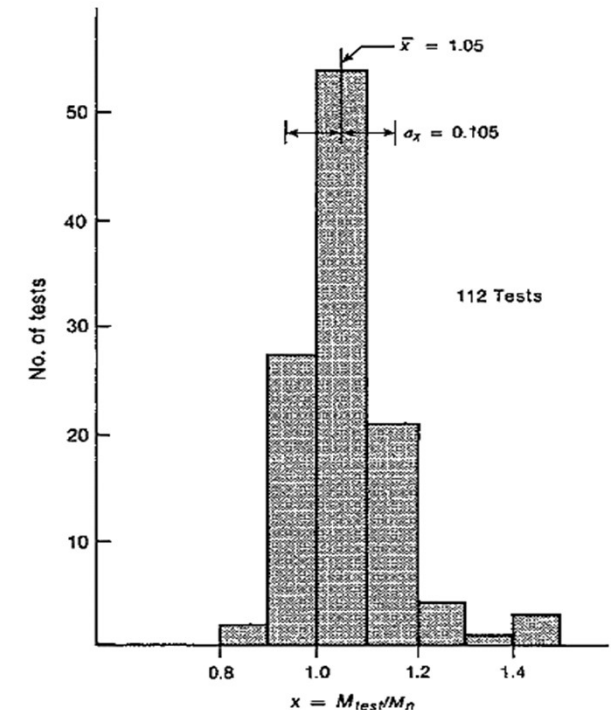

Comparison of measured and computed failure moments
(Reinforced Concrete: Mechanics & Design by James K. Wight, ch#2, pp# 17)



Design Approach

□ Factor of Safety (FOS)

2. Variability in Loads

- All loadings are variables, especially live loads and environmental loads due to snow, wind, or earthquakes.
- In addition to actual variations in the loads themselves, the assumptions and approximations made in carrying out structural analysis leads to differences between the actual forces and moments and those computed by the designer.



Design Approach

□ Factor of Safety (FOS)

2. Variability in Loads

- Fig shows variation of Live loads in a family of 151sft offices.
- The average (for 50 % buildings) sustained live load was around 13 psf in this sample.
- 1% of measured loads exceeded 44 psf.
- Building code specifies 50 psf for such buildings (ASCE 7-16).

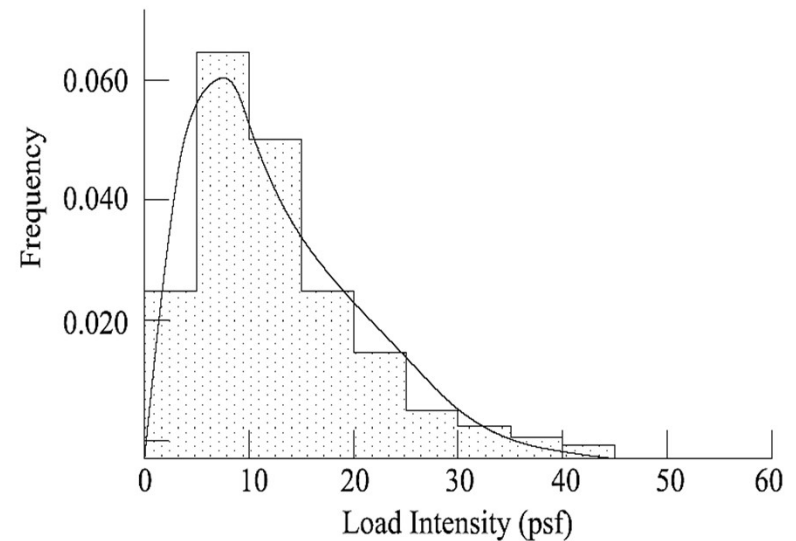

(a) Area = 151 ft²

Frequency distribution of sustained component of live loads in offices

(Reinforced Concrete: Mechanics & Design by James K. Wight, ch#2, pp# 18)



Design Approach

□ Factor of Safety (FOS)

▪ Consequences of Variability

- Due to the variability of resistances and load effects, there is definite chance that a weaker-than-average structure will be subjected to a higher-than-average load.
- In extreme cases, failure may occur.
- The load factors and resistance factors are selected to reduce the probability of failure to a very small level.



Design Approach

□ Factor of Safety (FOS)

▪ Incorporation of FOS in Design

- To integrate FOS into the design process, there are two fundamental approaches available:
 1. Working Stress Method
 2. Strength Design Method



Design Approach

□ Factor of Safety (FOS)

▪ Incorporation of FOS in Design

1. Working Stress Method

- In this method, the demand is kept the same while the capacity is divided by 2.
- This method assumes concrete and steel act together elastically where the relationship between loads and stresses is linear.
- Factor of safety is arbitrary.
- No need to check for serviceability limit states.



Design Approach

□ Factor of Safety (FOS)

▪ Incorporation of FOS in Design

2. Limit State Method

- The Limit State Method, also known as "Strength Design Method" considers both Ultimate and serviceability states.
- This method assumes that both concrete and steel are in their nonlinear inelastic stages.
- The factor of safety in the strength design method is achieved by magnifying the demand and lowering the capacity.



Design Approach

□ Factor of Safety (FOS)

▪ Incorporation of FOS in Design

2. Limit State Method

- $\phi M_n \geq M_u (\alpha M_s)$

- $\phi V_n \geq V_u (\alpha V_s)$

- $\phi P_n \geq P_u (\alpha P_s)$

- $\phi T_n \geq T_u (\alpha T_s)$

ϕ = Strength reduction factor

α = Demand amplification factor

$n \Rightarrow$ nominal

$u \Rightarrow$ ultimate

$s \Rightarrow$ service

- Note that here, the term α / ϕ represents the Factor of Safety which can be calculated based on scientific rationale.

How ?



Probabilistic Calculation of FOS

□ Resistance vs. Load Effects

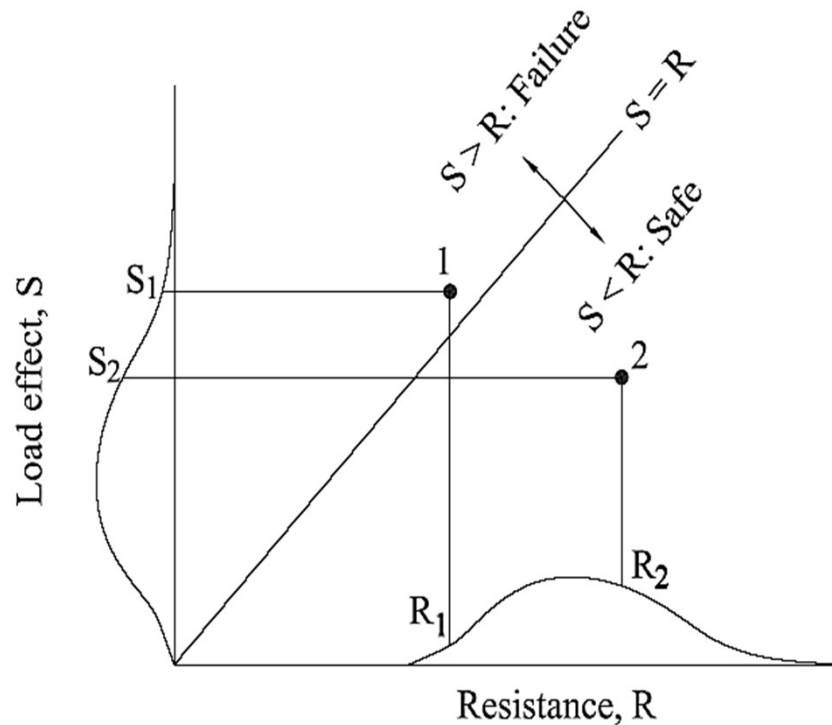

“S vs. R”

- R = The distribution of a population of resistance of a group of similar structure.
- S = Distribution of the maximum load effects, S, expected to occur on those structure during their lifetimes.
- The 45° line corresponds to $S = R$.
- $S > R$ is failure
- $S < R$ is Safety.



Probabilistic Calculation of FOS

□ Resistance vs. Load Effects

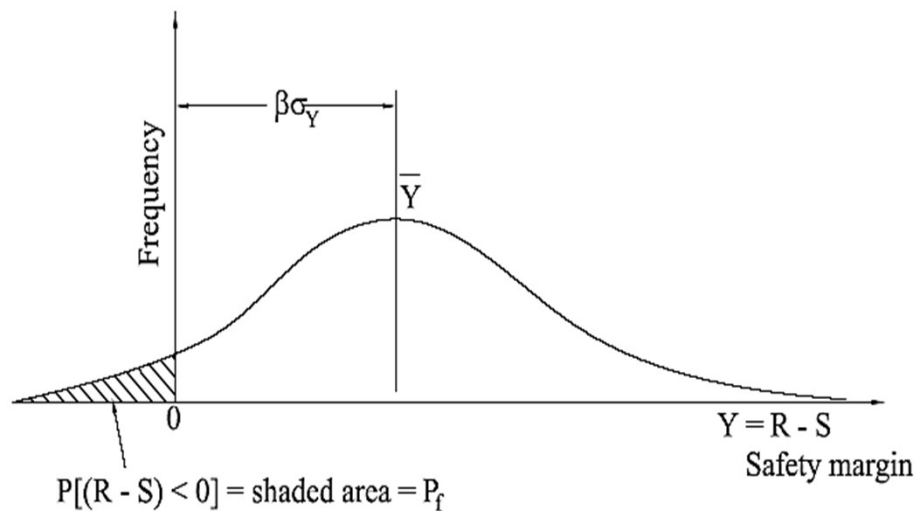

Safety margin vs. frequency (success or failure)

- Safety margin can be represented as
 $Y = R - S$
- Graph shows plot between safety margin (Y) and frequency of occurrence (success or failure).
- If Y is greater than 0, then safety margin exists, and failure is avoided.
- Failure will occur if Y is negative, represented by the shaded area in figure.



Probabilistic Calculation of FOS

□ Probability of Failure

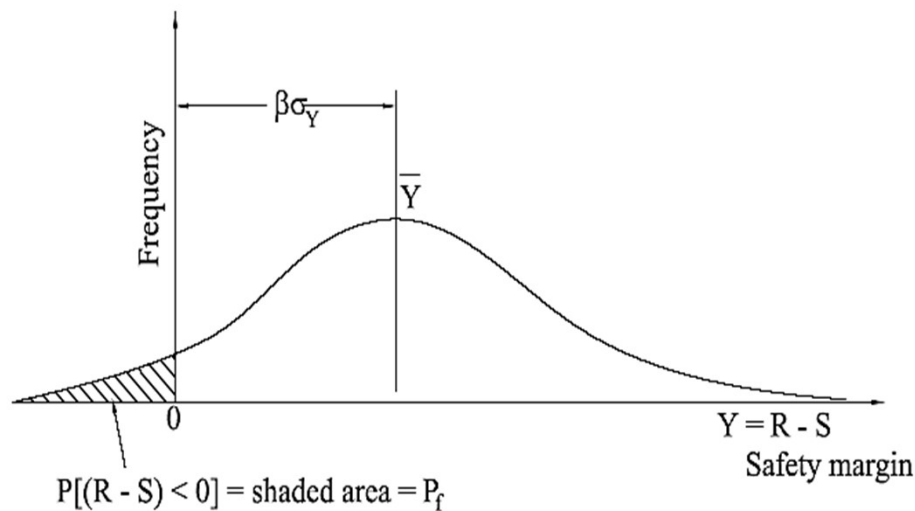

Safety margin vs. frequency (success or failure)

- The probability of failure, P_f , is the chance that a particular combination of R and S will give a negative value of Y .
- In normal distribution curve, P_f is equal to the ratio of the shaded area to the total area under the curve in figure.
- From the figure, mean value of Y is given as $Y = 0 + \beta\sigma_Y$
 - Where, $\sigma_Y = \text{Standard Deviation}$;
 $\beta = 1, 2, 3 \dots$



Probabilistic Calculation of FOS

□ The Safety Index

- Now larger the distance $\beta\sigma_Y$, the lesser will be the negative part and more will be the positive part in the curve, which means less chance of failure and more safety. The factor β is called the safety index.
- More positive part on the curve means increasing R. But increase in resistance will require compromise on economy.

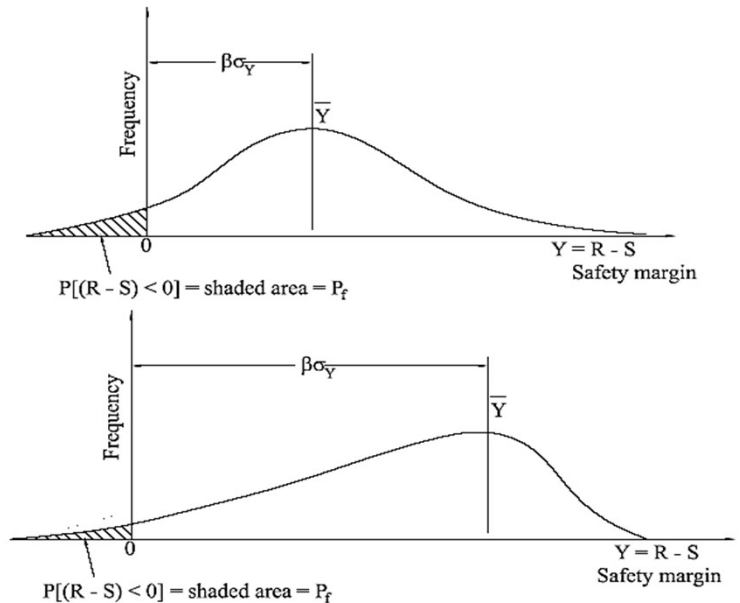



Probabilistic Calculation of FOS

□ Calculation of P_f

- The probability of failure (P_f) which is Probability that ($Y = R - S$) < 0 , can be calculated by converting the normal distribution (which is function of Y) to standard normal distribution (which is a function of Z) and then using standard normal distribution tables to find the area under the curve.
- From standard statistics tables, the probability of failure for $\beta = 3.5$ is $P(Z) = 0.0001 = 0.01\% = 1/9091$
- It means that roughly 1 in every 10,000 structural members designed on the basis that $\beta = 3.5$ may fail due to excessive load or under strength sometime during its lifetime.



Probabilistic Calculation of FOS

□ Selection of P_f and β

- The appropriate values of P_f and hence of β are chosen by bearing in mind the consequences of failure.
- Based on current design practice, β is taken between 3 and 3.5 for ductile failure with average consequences of failure and between 3.5 and 4 for sudden failure or failures having serious consequences.



Probabilistic Calculation of FOS

□ Selection of P_f and β

- In strength design method, we know that:

$$\gamma M_s = \phi M_n$$

$$FOS = \frac{M_n}{M_s} = \frac{\gamma}{\phi}$$

$$\text{For } \phi M_n = 1.2M_D + 1.6M_L$$

$$\text{Let } M_L = M_D; \text{ then } \phi M_n = 2.8M_D$$

Therefore,

$$FOS = M_n/M_D = 2.8/\phi$$

$$\text{For } \phi = 0.65; M_n/M_D = 4.3 \approx \beta$$

$$\text{For } \phi = 0.90; M_n/M_D = 3.11 \approx \beta$$

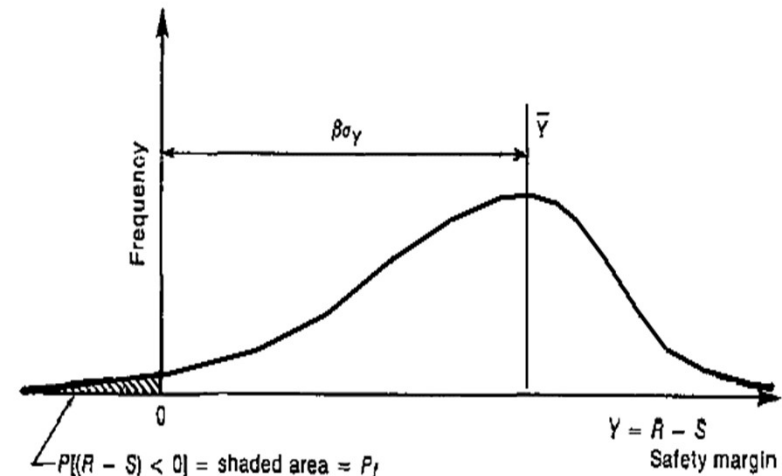



Design Procedure of the ACI Code

□ Definition of Strength Design Method

- Design strength of a member and its joints and connections, in terms of moment, axial force, shear, torsion, and bearing, shall be taken as the nominal strength S_n multiplied by the applicable strength reduction factor ϕ (ACI 4.6.1).
- Structures and structural members shall have design strength at all sections, ϕS_n , greater than or equal to the required strength U calculated for the factored loads and forces in such combinations as required by this Code or the general building code (ACI 4.6.2).



Design Procedure of the ACI Code

□ Definition of Strength Design Method

- In the AISC Specifications for steel design, the same design process is known as LRFD (Load and Resistance Factor Design).
- Strength design and LRFD are methods of limit-state design, except that primary attention is always placed on the ultimate limit states, with the serviceability limit states being checked after the original design is completed.



Design Procedure of the ACI Code

□ Design Loads

- Loads shall include self-weight, applied loads, and effects of Prestressing, earthquake, constraint of volume change, and differential settlement (ACI 5.2.1).
- Provisions in the Code are associated with dead, live, wind, and earthquake loads such as those recommended in ASCE/SEI 7 (ACI R5.2.1).



Design Procedure of the ACI Code

□ Design Loads

- If the service loads specified by the general building code differ from those of ASCE/SEI 7, the general building code governs. However, if the nature of the loads contained in a general building code differs considerably from ASCE/SEI 7 loads, some provisions of this Code may need modification to reflect the difference (ACI R5.2.1).



Design Procedure of the ACI Code

□ ASCE Recommendations on Loads

- ASCE 7-16 sections 1 to 10 are related to design loads for buildings and other structures.
- The sections are named as: general, combinations of loads, (dead loads, soil loads and hydrostatic pressure), live, flood, tsunami, snow, rain, (reserve for future provisions) and ice loads.

Brief visit of ASCE 7-16



Design Procedure of the ACI Code

□ Loads on Structure During Construction

- During the construction of concrete buildings, the weight of the fresh concrete is supported by formwork, which frequently rests on floors lower down in the structure.

- ACI 26.11.2.1(c) states that:

“No construction loads shall be placed on, nor any formwork removed from, any part of the structure under construction except when that portion of the structure in combination with remaining formwork has sufficient strength to support safely its weight and loads placed thereon and without impairing serviceability”.



Design Procedure of the ACI Code

□ Load Combinations

- The design load combinations as per ACI Code and UBC are:

ACI 318-19 section 5.3

- $1.4D$
- $1.2D + 1.6L$
- $1.2D + 1.0E + 1.0L$
- $0.9D + 1.0E$

UBC 97 section 1928.1.2.3

- $1.4D$
- $1.4D + 1.7L$
- $1.2D + 1.5E + 0.5L$
- $0.9D + 1.5E$

Where;

D = dead load, L = live load and E = Earthquake load



Design Procedure of the ACI Code

□ Strength Reduction Factors

- The Strength reduction factors, as per the ACI Code and UBC, are listed in the table below:

Actions	Strength Reduction Factors ϕ	
	ACI 318-19 (21.2)	UBC 97 (1909.3.2)
Tension-controlled	0.90	0.90
Shear and torsion	0.75	0.85
Compression-controlled (spiral)	0.75	0.75
Compression-controlled (other)	0.65	0.70
Bearing	0.65	0.70



Design Procedure of the ACI Code

□ Customary Dimensions and Construction Tolerance

- The actual as-built dimensions will differ slightly from those shown on the drawings, due to construction inaccuracies.
- ACI Committee 117 has published a comprehensive list of tolerance for concrete construction and materials.
- As an example, tolerances for footings are +2 inches and -1/2 inch on plan dimensions and -5 percent of the specified thickness.



References

- Reinforced Concrete - Mechanics and Design (7th Ed.) by James MacGregor.
- Building Code Requirements for Structural Concrete (ACI 318-19)
- Portland Cement Association (PCA 2002)