



Lecture 04

Design of Two-Way Slabs Without Beams (Flat Plates and Flat Slabs)

By:

Prof. Dr. Qaisar Ali

Civil Engineering Department

UET Peshawar

drqaisarali@uetpeshawar.edu.pk

www.drqaisarali.com



Lecture Contents

- **Part – I Analysis and Design of two-way slab Systems without beams for Flexure**
 - Background
 - Direct Design Method (DDM)
 - Analysis Procedure using DDM
 - Example 5.1
 - Other ACI Provisions for Flat Slabs



Lecture Contents

- **Part – II Analysis and Design of two-way slab Systems without beams for Shear**
 - Introduction
 - Design of Slabs for Punching Shear
 - Example 5.2
- References



Learning Outcomes

- **At the end of this lecture, students will be able to;**
 - ***Design*** flat slabs and flat plates for flexure using Direct Design Method (DDM)
 - ***Design*** flat slabs and flat plates for shear



Section – I

Flexural Design of Two-Way Slab System without Beams (Flat Plates and Flat Slabs)



Direct Design Method

□ Background

- In previous lectures, a 90' x 60' Hall (as shown below) was analyzed as a one-way slab system using ACI approximate coefficients.

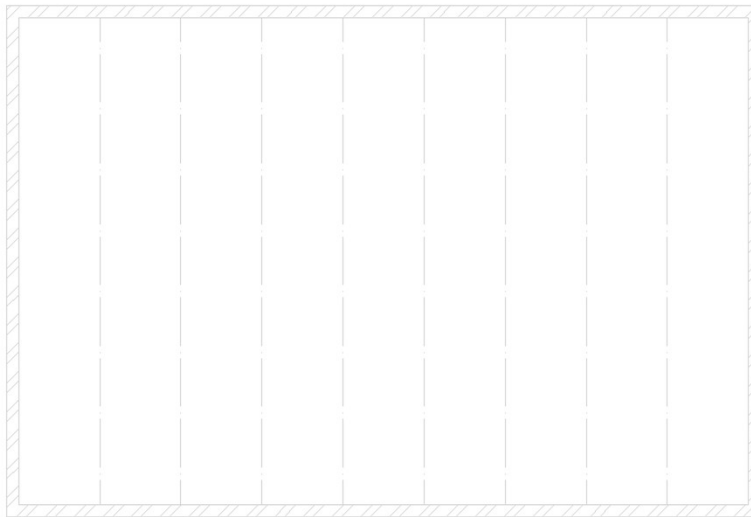

Option 1

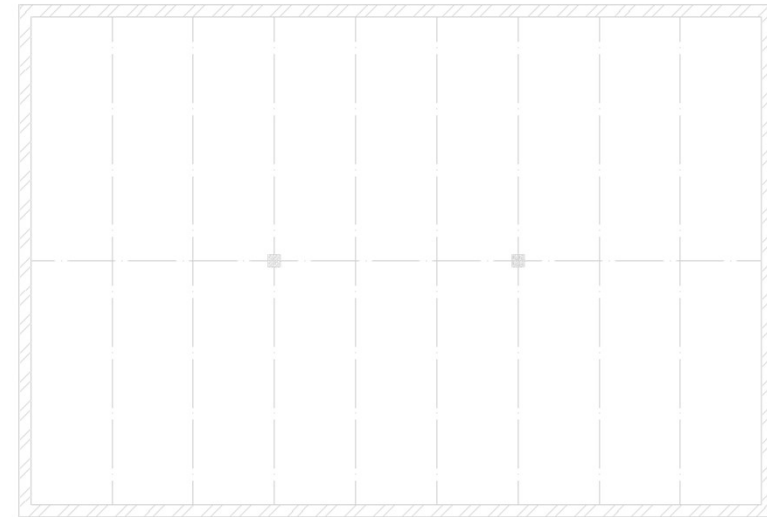

Option 2



Direct Design Method

□ Background

- Also, in previous lecture, the slab of 100' x 60' commercial building was analyzed as slab with beams using Moment coefficient method.

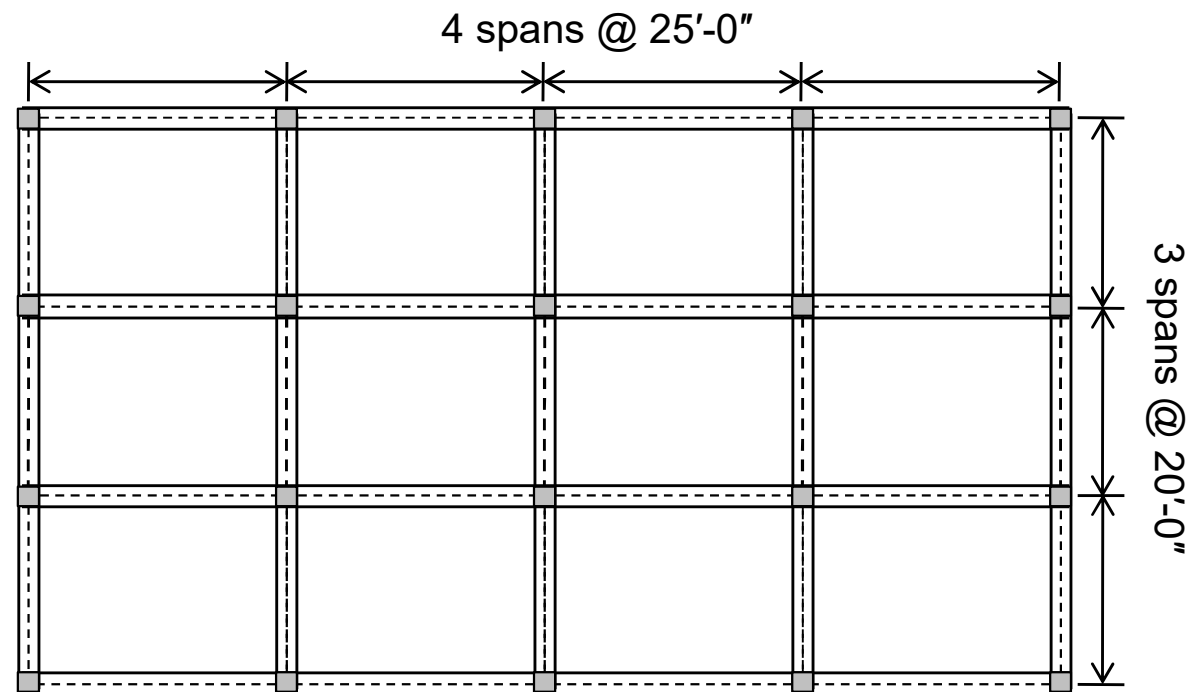



Direct Design Method

□ Background

- In the same 100' x 60' commercial building, if there are shallow or no beams, Moment Coefficient Method cannot be used.
- For such cases, the Direct Design Method (DDM) can be used.



Direct Design Method

□ Introduction

- The Direct Design Method (DDM) consists of a set of rules for distributing moments to slab and beam sections to satisfy safety requirements and most serviceability requirements simultaneously.
- The DDM is applicable to two-way slabs both with and without beams. However, it becomes comparatively challenging when dealing with slabs that have beams or walls. Hence, it will be only used for slabs without beams.
- Although the provisions for DDM present in ACI 318-14 Section 8.10 have been eliminated from the latest version (ACI 318-19), it can still be used as per ACI R6.2.4.1.



Direct Design Method

□ Introduction

- In DDM, frames rather than panels are analyzed.

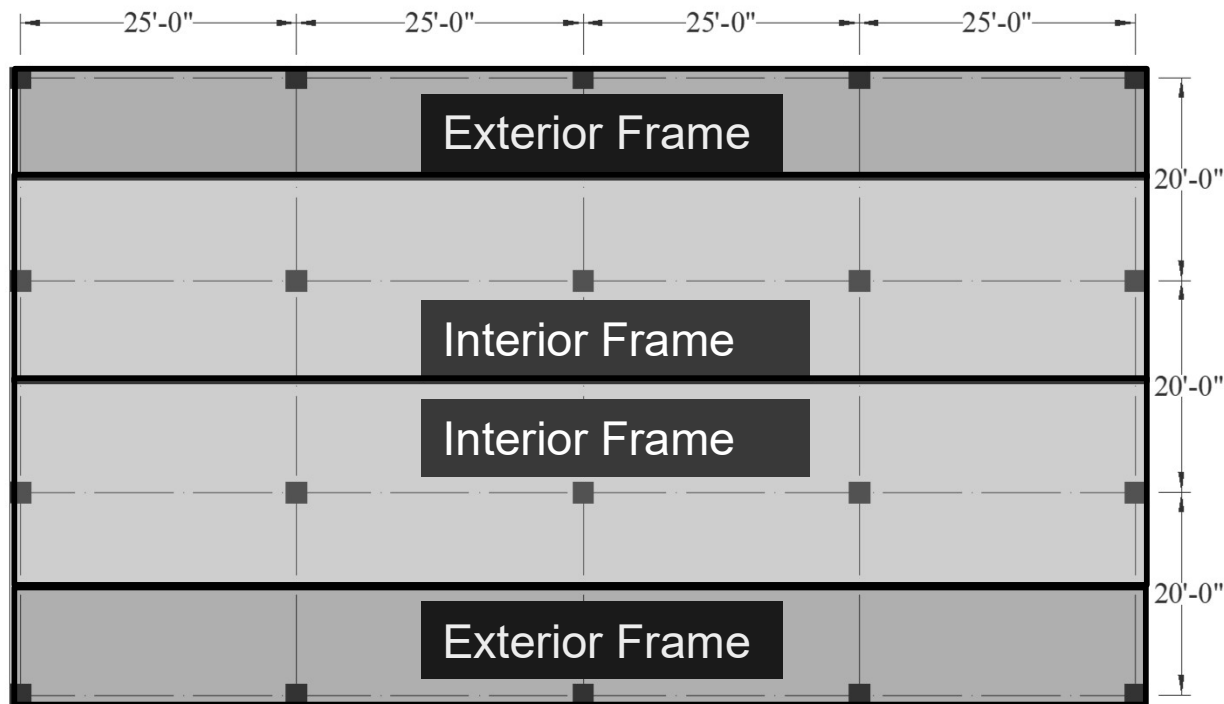



Direct Design Method

□ Introduction

- For complete analysis of slab system, frames are analyzed in E-W and N-S directions.

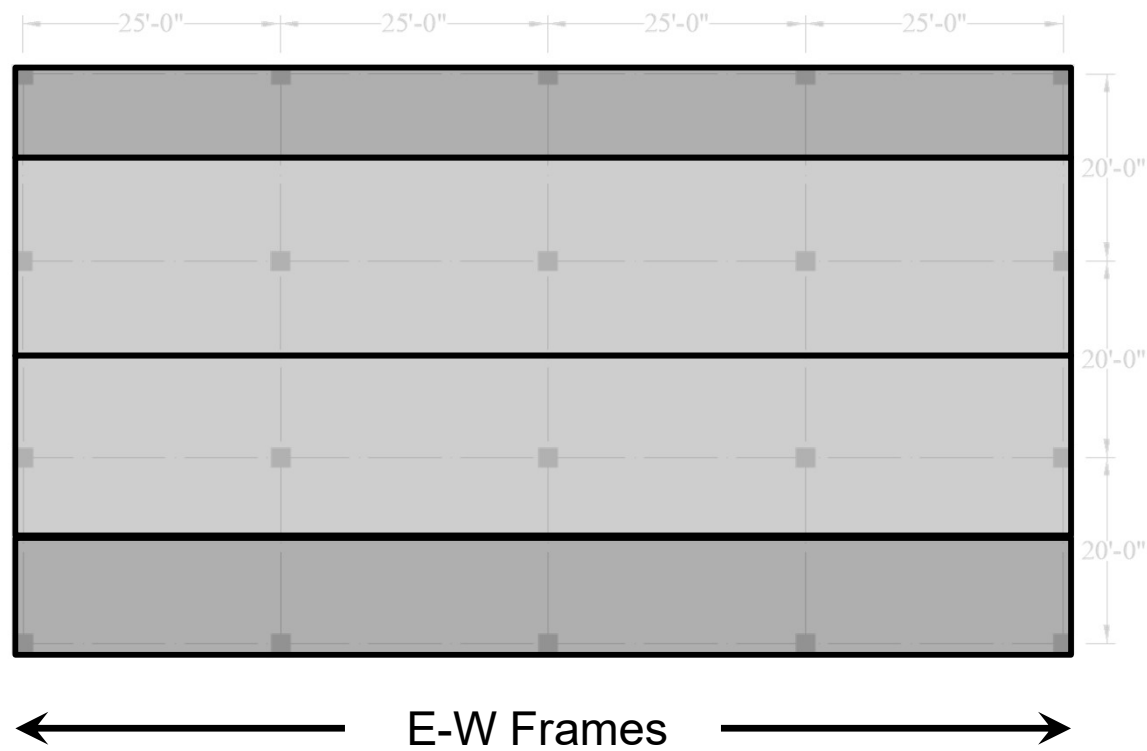



Direct Design Method

□ Introduction

- For complete analysis of slab system, frames are analyzed in E-W and N-S directions.

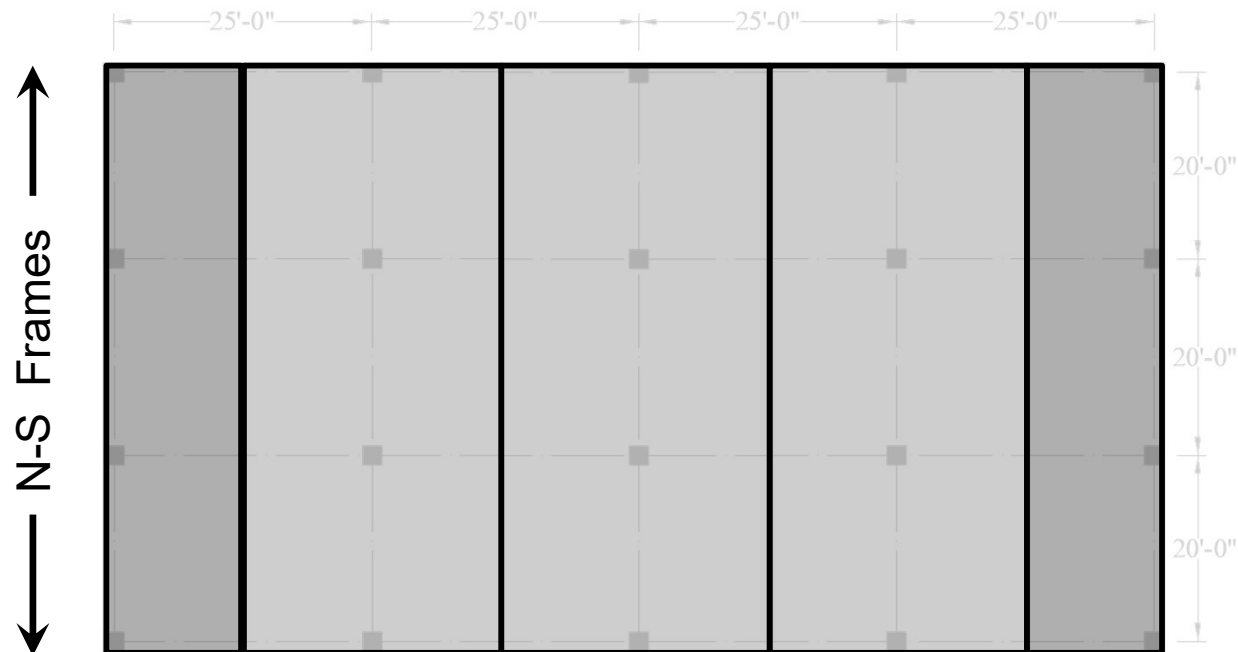



Direct Design Method

□ Limitations

- Though DDM is useful for analysis of slabs, specially without beams, the method is applicable with some limitations as discussed next.



Direct Design Method

□ Limitations (ACI 8.10.2)

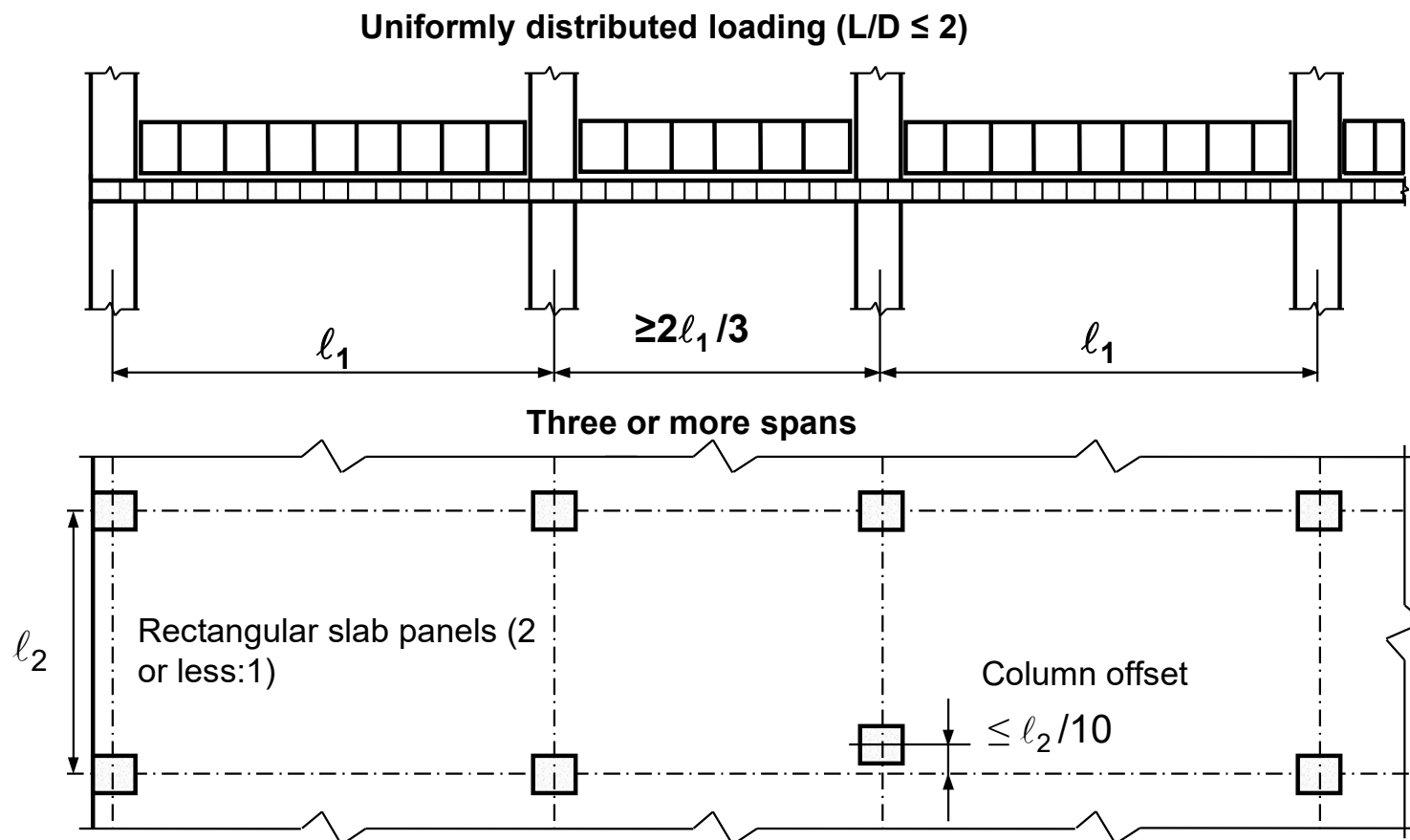



Analysis Procedure using DDM

□ Step 1: Selection of Sizes

- ACI table 8.3.1.1 is used for finding the slab thickness.

f_y (psi)	Without drop panels			With drop panels		
	Exterior Panels		Interior panels	Exterior Panels		Interior panels
	Without edge beams	With edge beams		Without edge beams	With edge beams	
40,000	$l_n/33$	$l_n/36$	$l_n/36$	$l_n/36$	$l_n/40$	$l_n/40$
60,000	$l_n/30$	$l_n/33$	$l_n/33$	$l_n/33$	$l_n/36$	$l_n/36$
80,000	$l_n/27$	$l_n/30$	$l_n/30$	$l_n/30$	$l_n/33$	$l_n/33$

- l_n is the clear span in the long direction, measured face-to-face of supports (in.).
- $h_{min} = 5''$ for slabs without drop panels
- $h_{min} = 4''$ for slabs with drop panels



Analysis Procedure using DDM

□ Step 2: Calculation of Loads

- The slab load is calculated in usual manner.

$$W_u = 1.2D + 1.6L$$

Where;

W_u = ultimate/ factored load

D = service dead load

L = service live load



Analysis Procedure using DDM

□ Step 3: Analysis

❖ Marking Frames in Each Direction

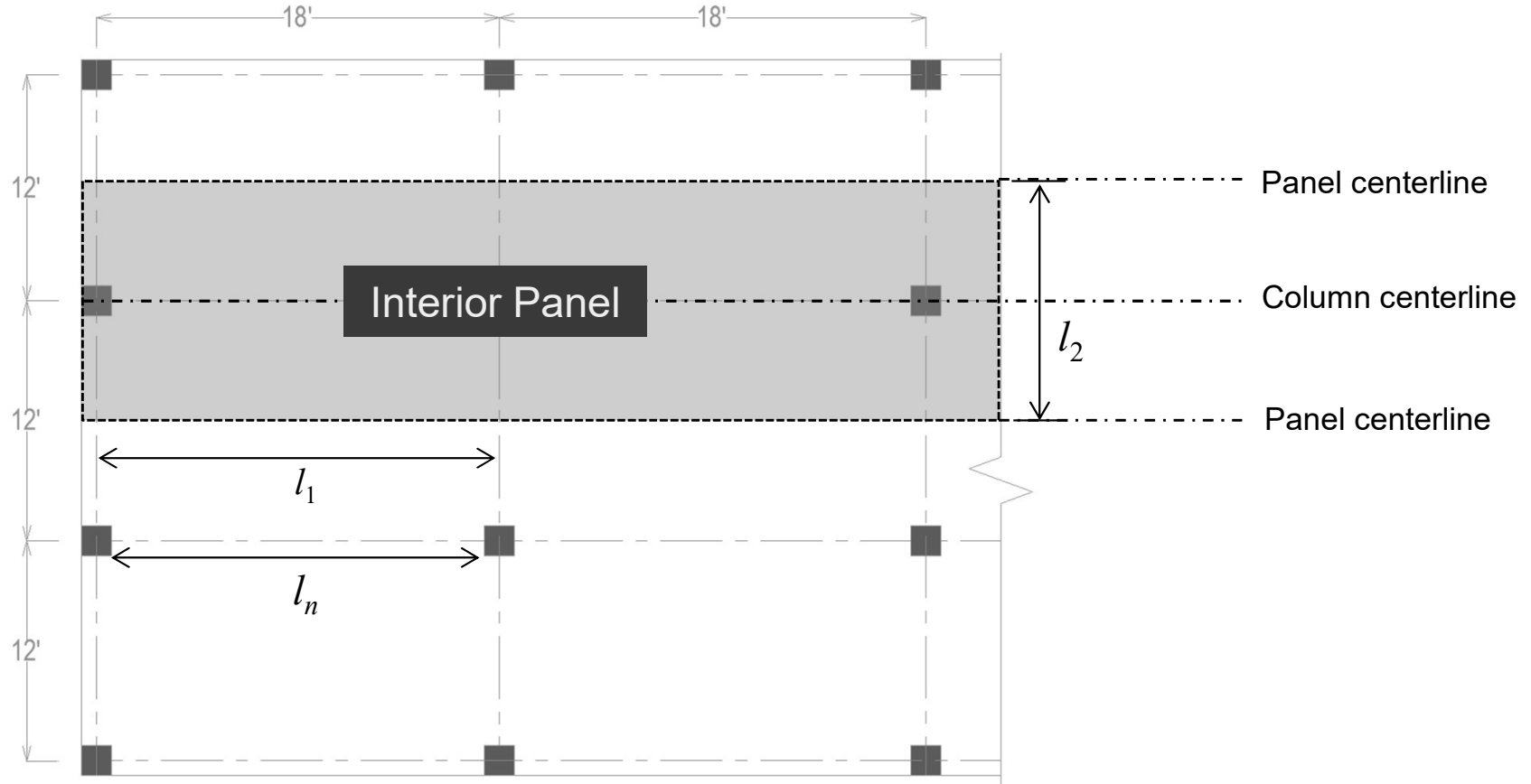



Analysis Procedure using DDM

□ Step 3: Analysis

❖ Marking Frames in Each Direction

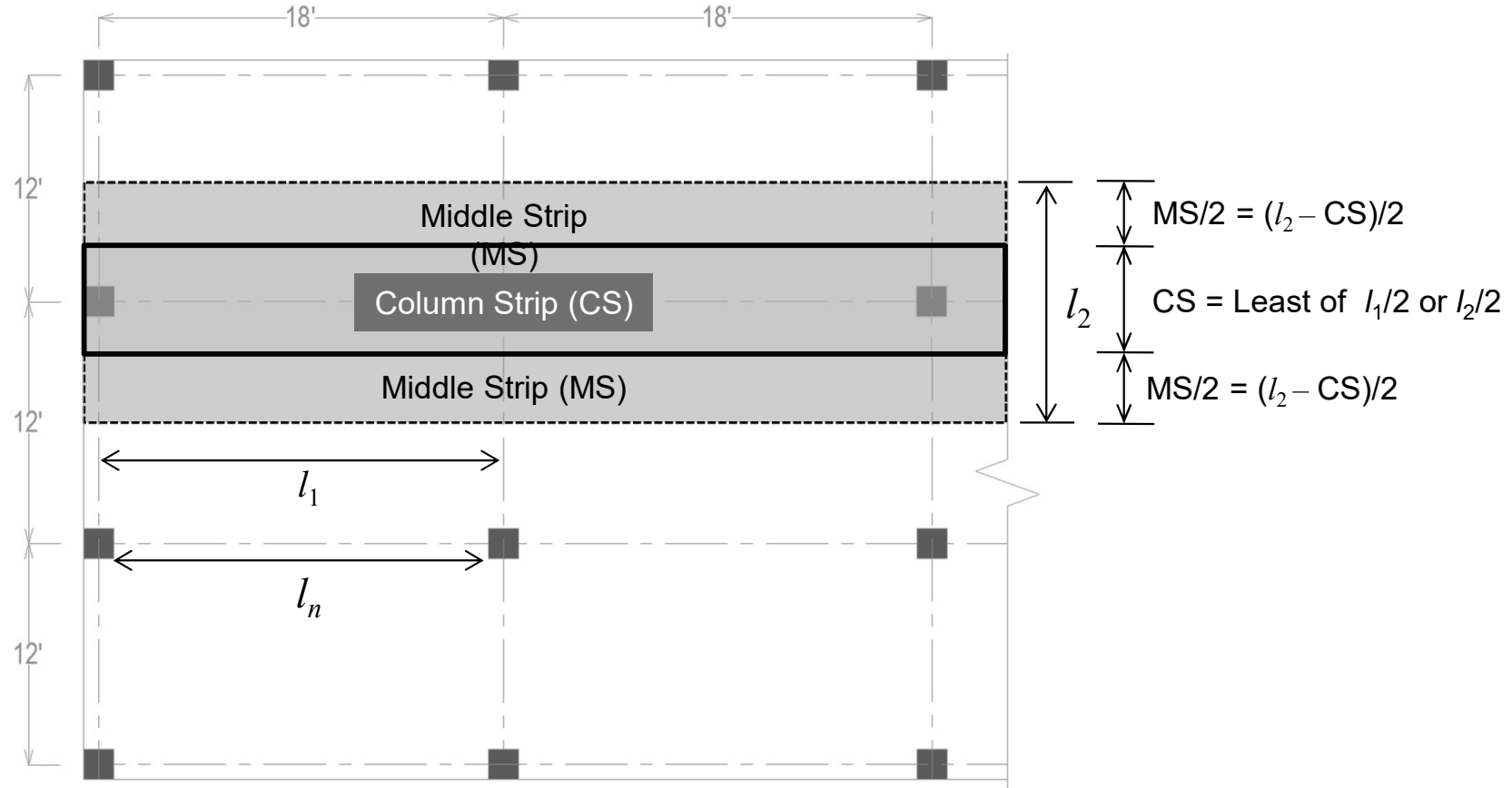



Analysis Procedure using DDM

□ Step 3: Analysis

❖ Marking Frames in Each Direction

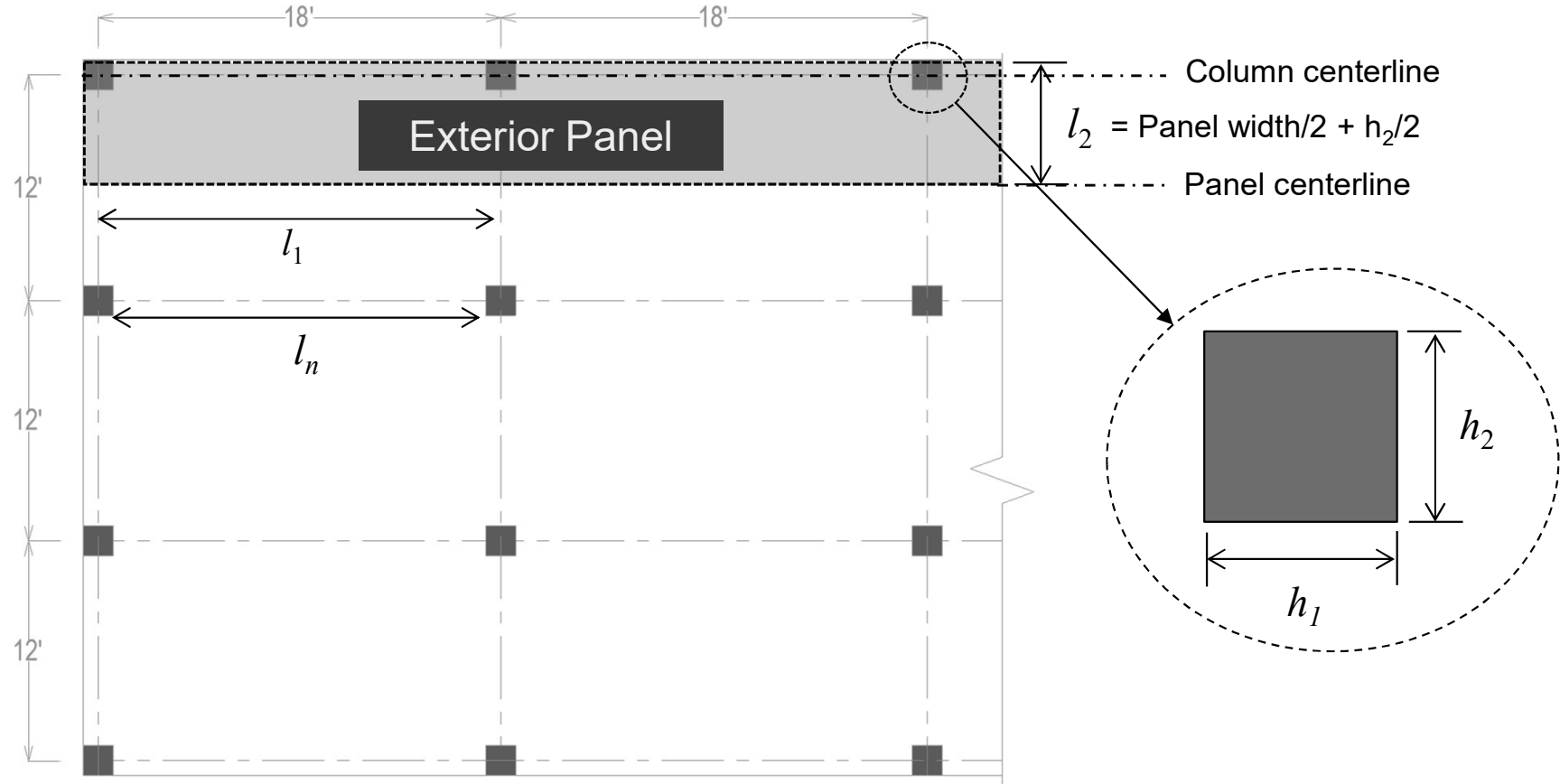



Analysis Procedure using DDM

□ Step 3: Analysis

❖ Marking Frames in Each Direction

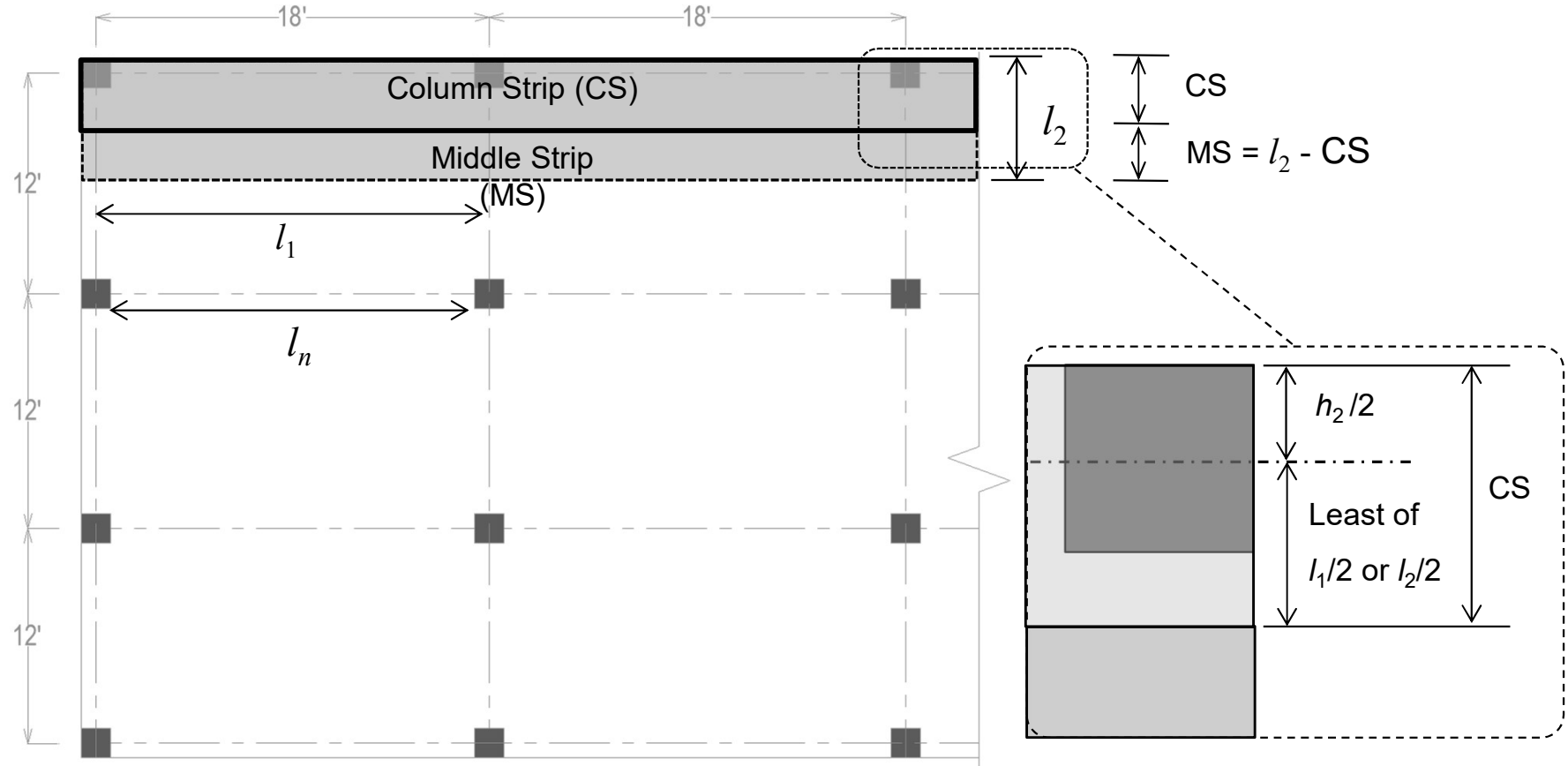



Analysis Procedure using DDM

□ Step 3: Analysis

❖ Total Static Moment

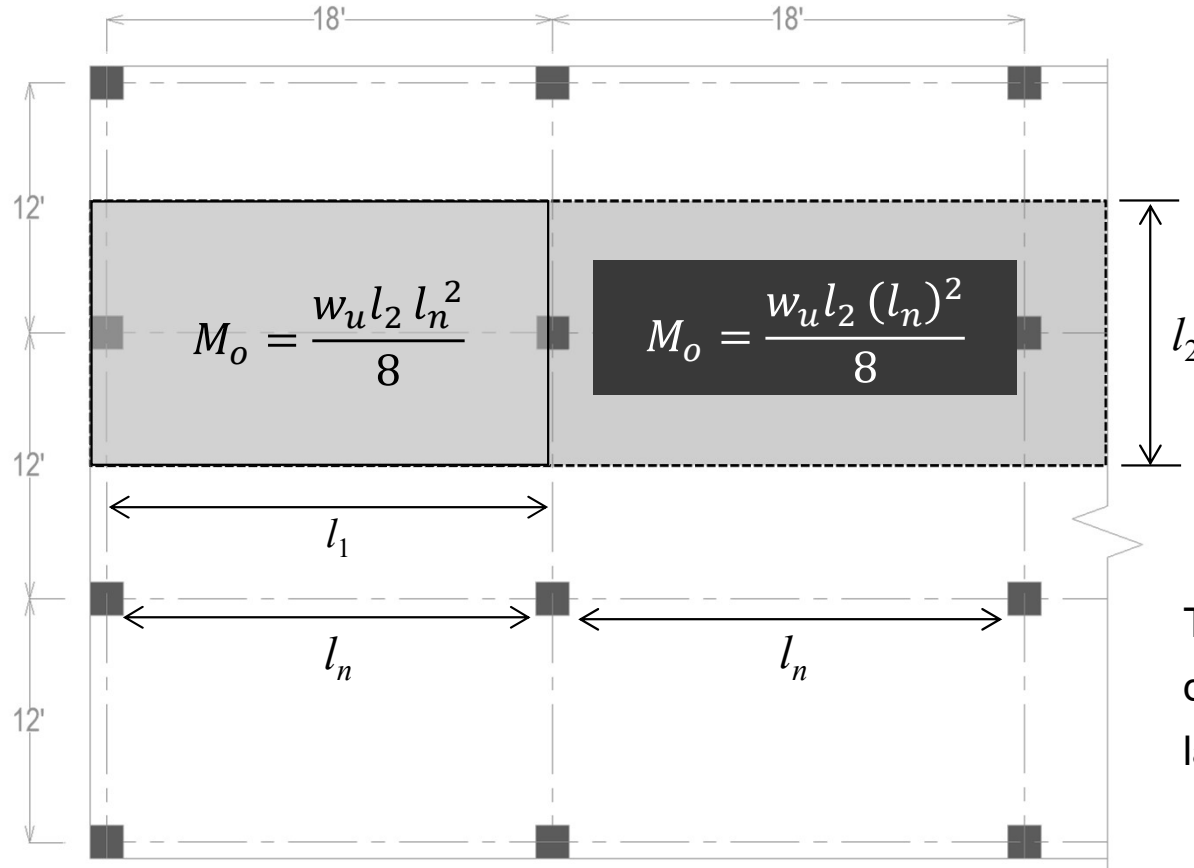

This total moment is then distributed longitudinally and laterally as illustrated next.



Analysis Procedure using DDM

□ Step 3: Analysis

❖ Longitudinal Distribution of Total Static Moment

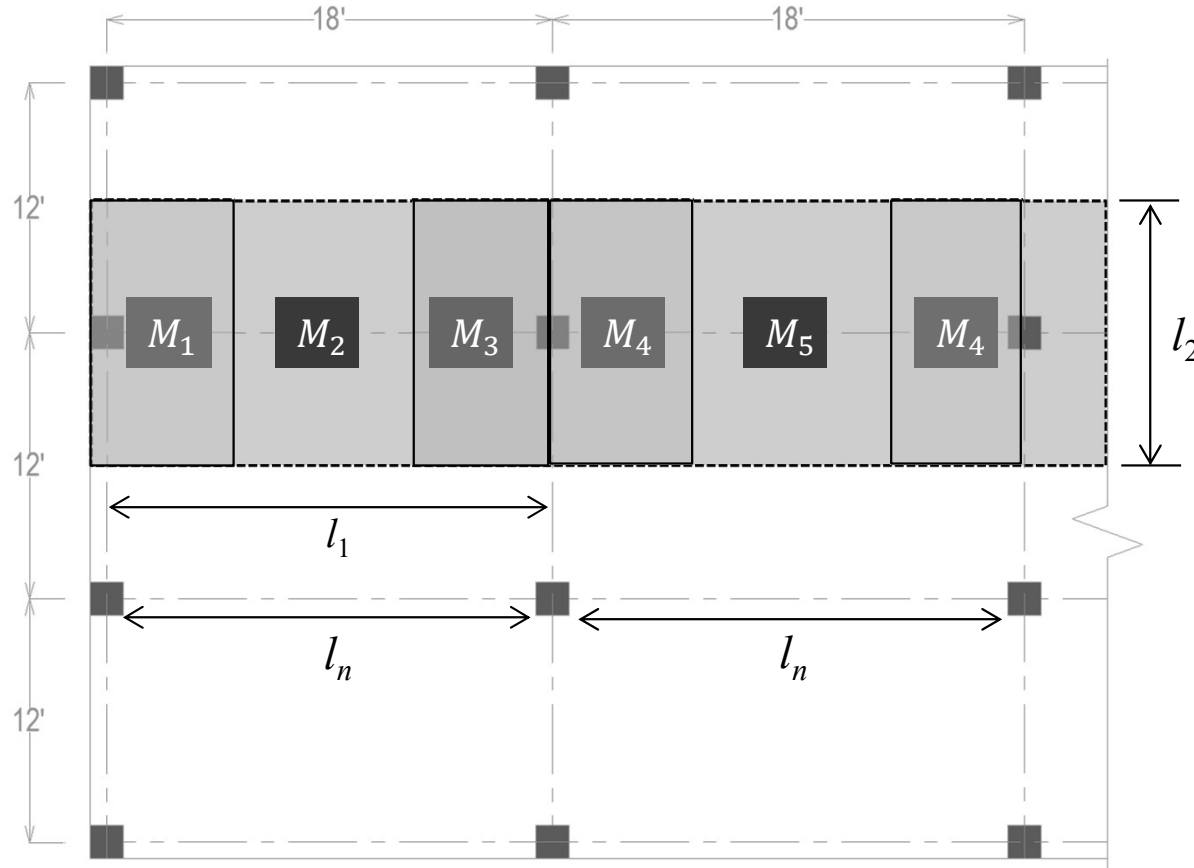

$$M_o = \frac{w_u l_2 l_n^2}{8}$$

$$M_1 = 0.26M_o$$

$$M_2 = 0.52M_o$$

$$M_3 = 0.70M_o$$

$$M_4 = 0.65M_o$$

$$M_5 = 0.35M_o$$



Analysis Procedure using DDM

□ Step 3: Analysis

❖ Lateral Distribution of Calculated Moments

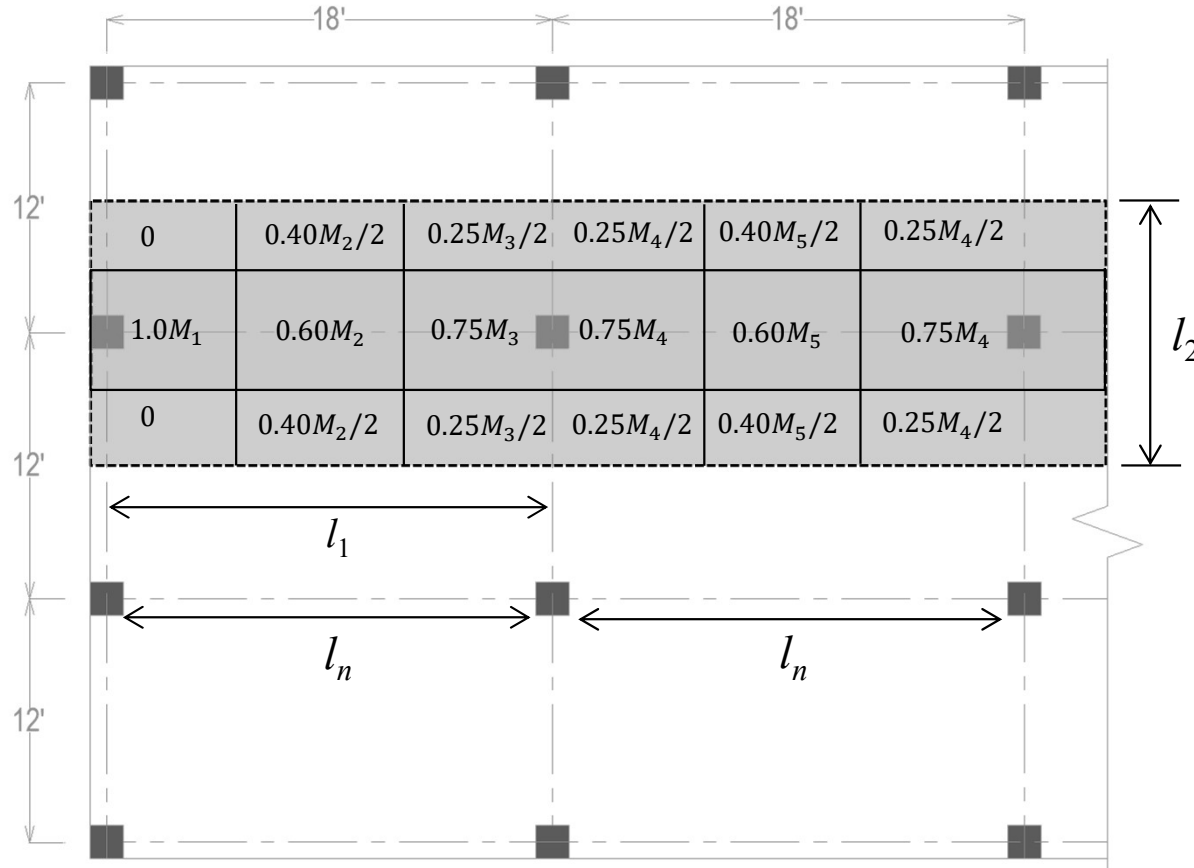

$$M_o = \frac{w_u l_2 l_n^2}{8}$$

$$M_1 = 0.26M_o$$

$$M_2 = 0.52M_o$$

$$M_3 = 0.70M_o$$

$$M_4 = 0.65M_o$$

$$M_5 = 0.35M_o$$



Example 5.1

□ Problem Statement

- **Analyze** the flat plate shown below using DDM. The slab supports a uniformly distributed live load of 144 psf. All columns are 14" square. Take $f'_c = 3$ ksi and $f_y = 60$ ksi





Example 5.1

□ Solution

➤ Step 1: Selection of sizes

- ACI table 8.3.1.1 is used for finding flat plate and flat slab thickness

Table 8.3.1.1 —Minimum thickness of nonprestressed two-way slabs without interior beams (in.)						
f_y (psi)	Without drop panels			With drop panels		
	Exterior Panels		Interior panels	Exterior Panels		Interior panels
	Without edge beams	With edge beams		Without edge beams	With edge beams	
40,000	$l_n/33$	$l_n/36$	$l_n/36$	$l_n/36$	$l_n/40$	$l_n/40$
60,000	$l_n/30$	$l_n/33$	$l_n/33$	$l_n/33$	$l_n/36$	$l_n/36$
80,000	$l_n/27$	$l_n/30$	$l_n/30$	$l_n/30$	$l_n/33$	$l_n/33$



Example 5.1

□ Solution

➤ Step 1: Selection of sizes

Exterior panel governs. Therefore;

$$h_{min} = \frac{l_n}{30} = \frac{25 - 2(14/12)}{30} = 0.76' \text{ or } 9.12''$$

Take $h_s = 10''$

Assuming #6 bar ;

$$d = h_s - 0.75 - 0.75 = 8.5''$$

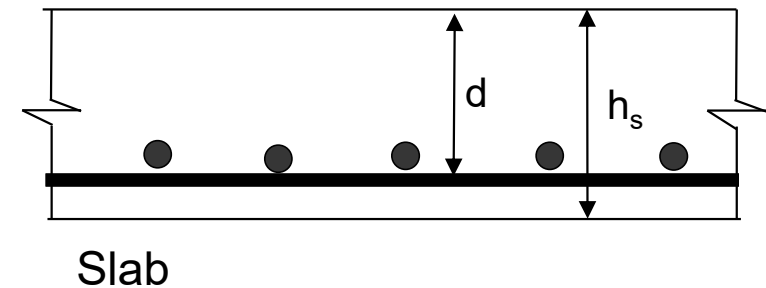



Example 5.1

□ Solution

➤ Step 2: Calculation of Loads

$$\text{Self-weight of plate} = h_s \gamma = (10/12) \times 0.150 = 0.125 \text{ ksf}$$

$$\text{Super imposed dead load} = \text{Nil}$$

$$\text{Service live load} = 0.114 \text{ ksf}$$

Now,

$$W_u = 1.2W_u + 1.6L = 1.2(0.125) + 1.6(0.144) = 0.3804 \text{ ksf}$$



Example 5.1

□ Solution

➤ Step 3: Analysis (E-W Direction)

❖ Marking Frames and Strips

From figure, we have

$$l_1 = 25' , l_2 = 20'$$

$$l_n = 25 - \left(\frac{14}{12}\right) = 23.83'$$

Now,

$$CS = \frac{\min(l_1, l_2)}{2} = 10'$$

and

$$MS/2 = (l_2 - CS)/2 = 5'$$

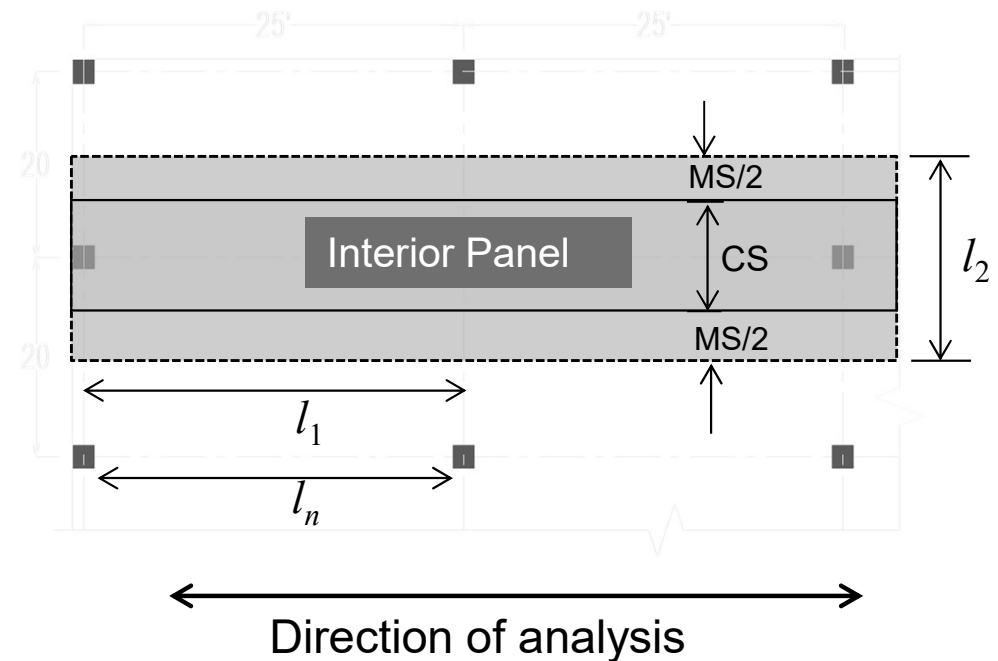



Example 5.1

□ Solution

➤ Step 3: Analysis (E-W Direction)

❖ Marking Frames and Strips

$$l_2 = \frac{20}{2} + 0.5 \left(\frac{14}{12} \right) = 10.58'$$

$$l_n = 25 - \left(\frac{14}{12} \right) = 23.83'$$

Now,

$$CS = \frac{20}{4} + 0.5 \left(\frac{14}{12} \right) = 5.58'$$

$$MS = (l_2 - CS)/2 = 5'$$

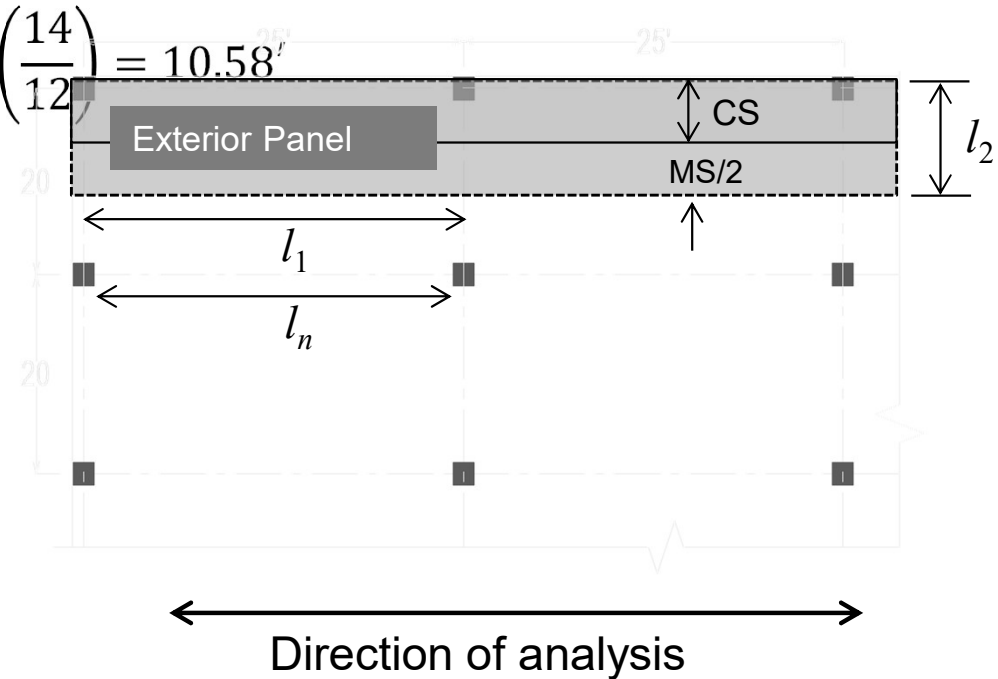



Example 5.1

□ Solution

➤ Step 3: Analysis (E-W Direction)

❖ Calculation of Total Static Moment (interior frame)

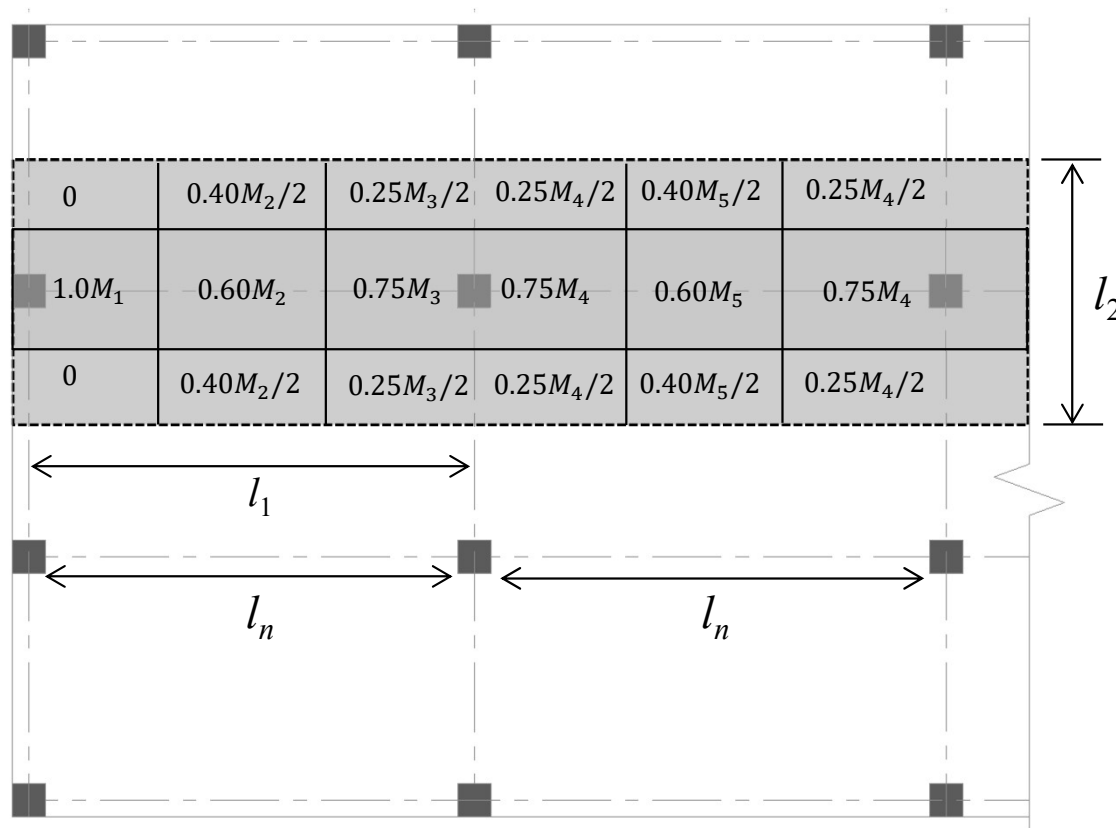

$$M_o = \frac{w_u l_2 l_n^2}{8}$$

$$M_1 = 0.26M_o$$

$$M_2 = 0.52M_o$$

$$M_3 = 0.70M_o$$

$$M_4 = 0.65M_o$$

$$M_5 = 0.35M_o$$



Example 5.1

□ Solution

➤ Step 3: Analysis (E-W Direction)

❖ Calculation of Total Static Moment (interior frame)

$$M_o = \frac{w_u l_2 (l_n)^2}{8}$$

$$M_o = \frac{0.381 \times 20 \times 23.83^2}{8}$$

$$M_o = 540.90 \text{ ft.kip}$$

This moment is distributed along longitudinal and lateral direction.

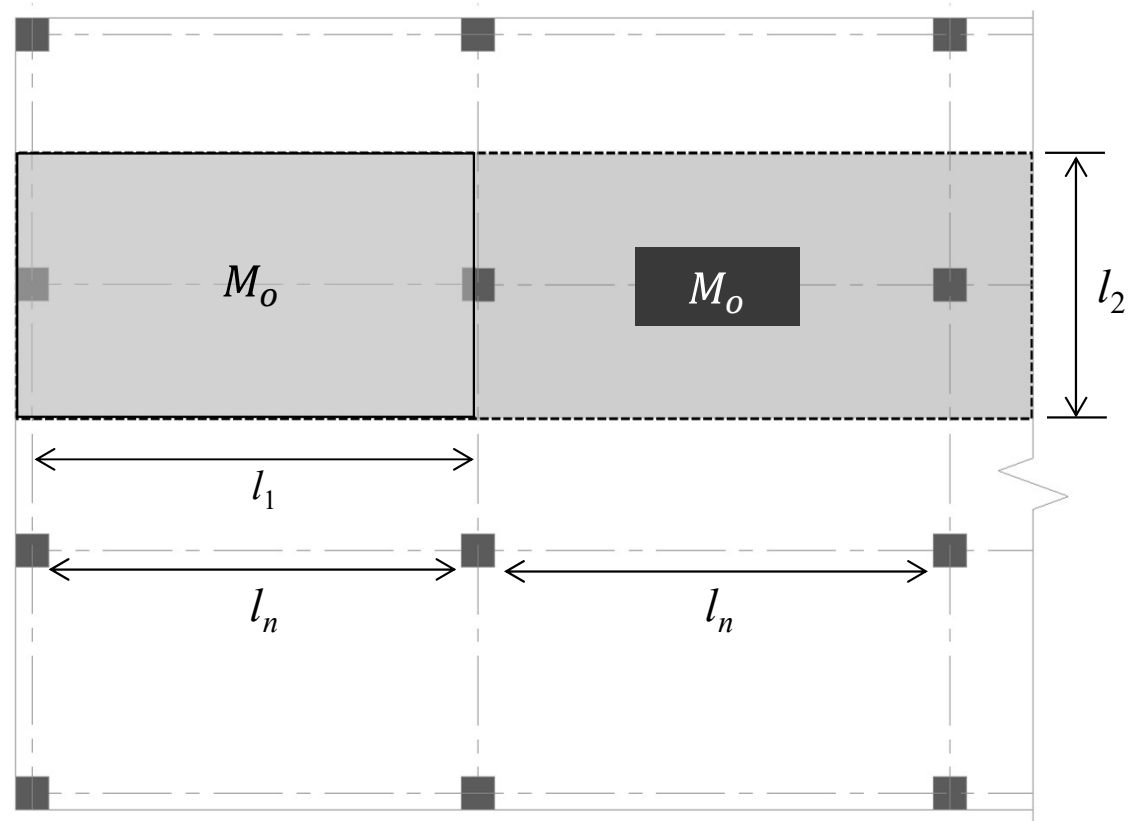



Example 5.1

□ Solution

➤ Step 3: Analysis (E-W Direction)

❖ Longitudinal Distribution of Moment (interior frame)

$M_1 = 0.26M_o$	140.63
$M_2 = 0.52M_o$	281.27
$M_3 = 0.70M_o$	378.63
$M_4 = 0.65M_o$	351.59
$M_5 = 0.35M_o$	189.32
All values are in ft.kip	

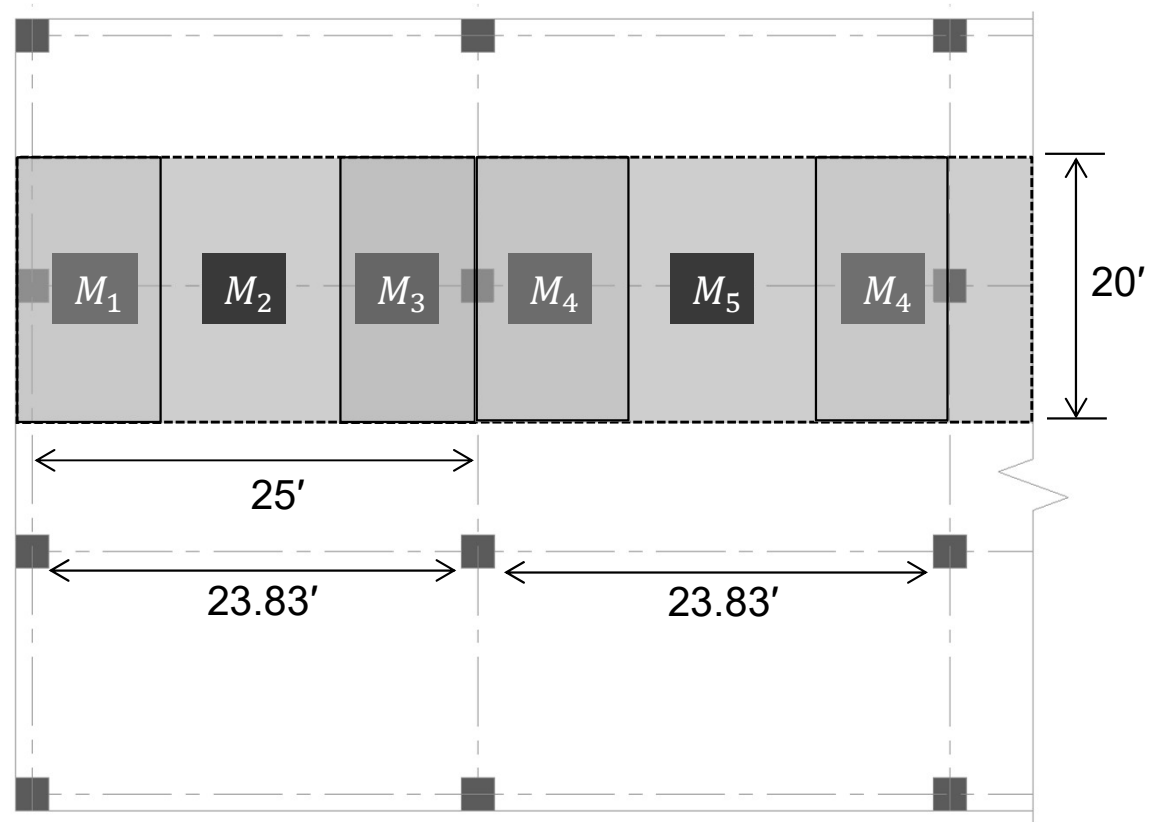



Example 5.1

□ Solution

➤ Step 3: Analysis (E-W Direction)

❖ Lateral Distribution of Moment (interior frame)

$M_1 = 0.26M_o$	140.63
$M_2 = 0.52M_o$	281.27
$M_3 = 0.70M_o$	378.63
$M_4 = 0.65M_o$	351.59
$M_5 = 0.35M_o$	189.32
All values are in ft.kip	

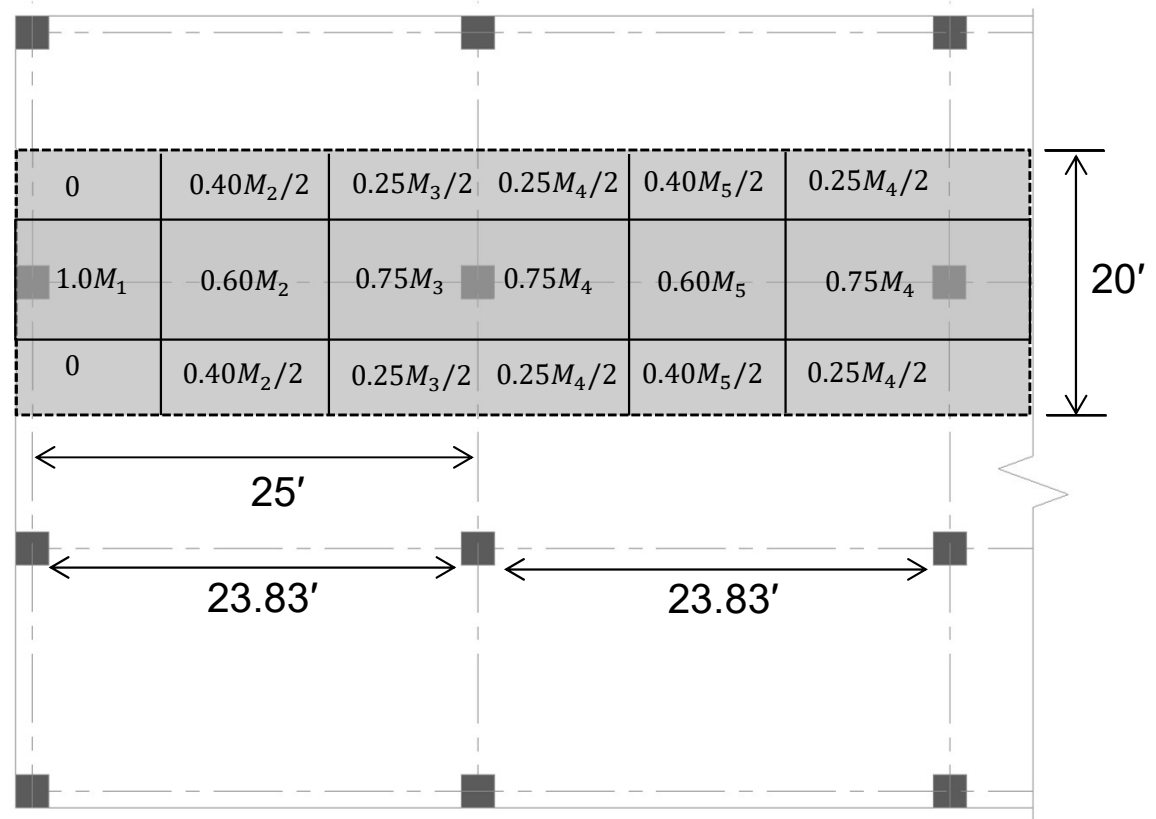



Example 5.1

□ Solution

➤ Step 3: Analysis (E-W Direction)

❖ Lateral Distribution of Moment (interior frame)

$M_1 = 0.26M_o$	140.63
$M_2 = 0.52M_o$	281.27
$M_3 = 0.70M_o$	378.63
$M_4 = 0.65M_o$	351.59
$M_5 = 0.35M_o$	189.32
All values are in ft.kip	

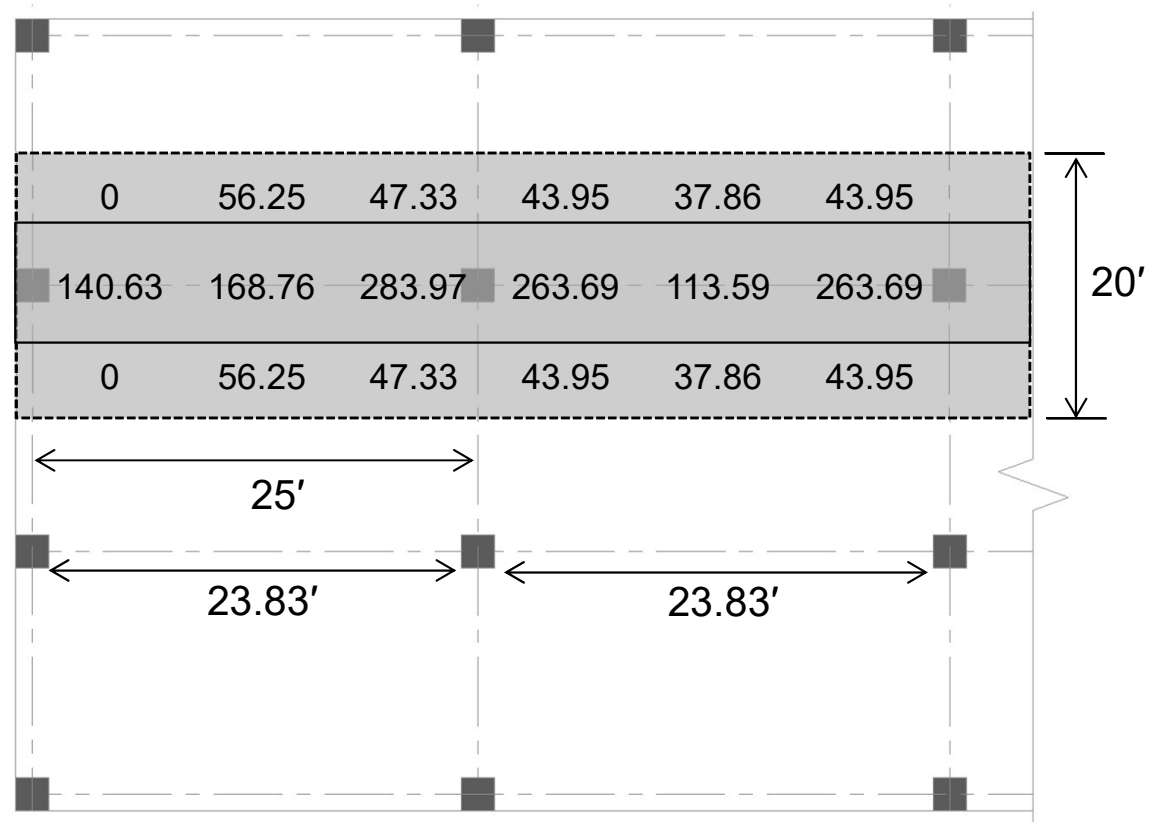



Example 5.1

□ Solution

➤ Step 3: Analysis (E-W Direction)

❖ Lateral Distribution of Moment (exterior frame)

$M_1 = 0.26M_o$	74.42
$M_2 = 0.52M_o$	148.83
$M_3 = 0.70M_o$	200.35
$M_4 = 0.65M_o$	186.04
$M_5 = 0.35M_o$	100.18
All values are in ft.kip	

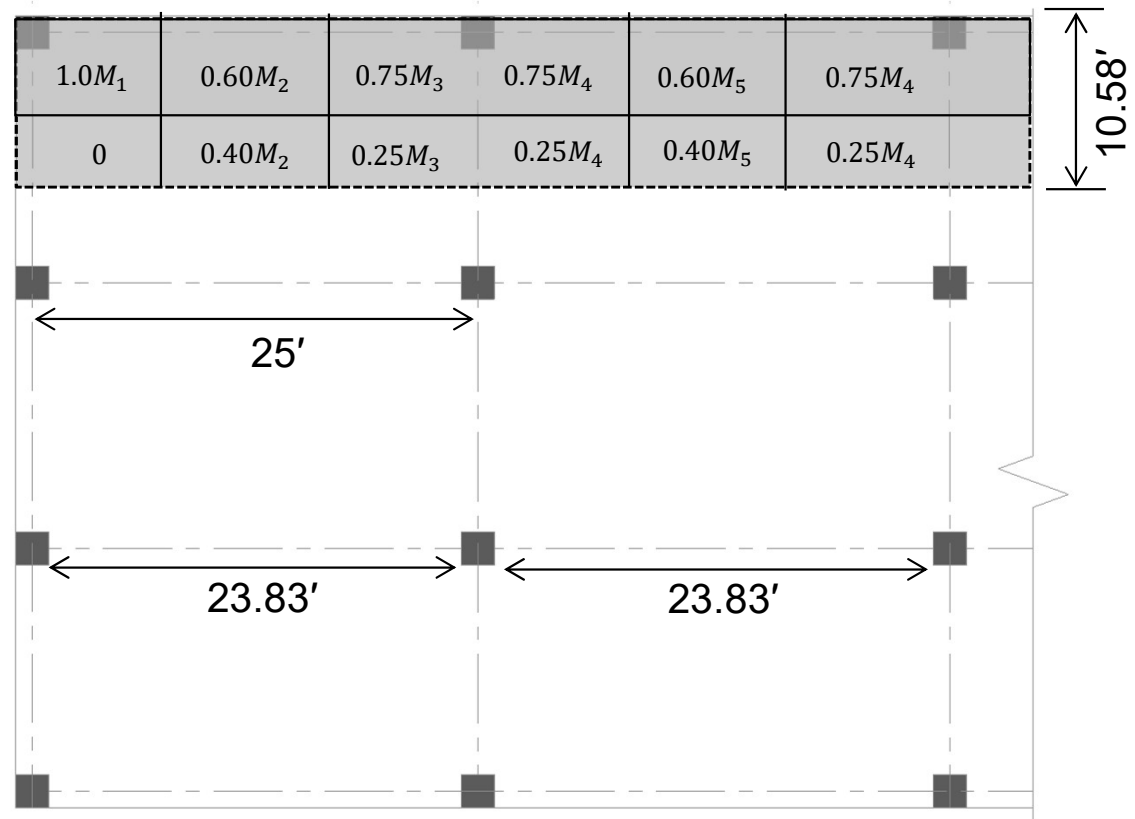



Example 5.1

□ Solution

➤ Step 3: Analysis (E-W Direction)

❖ Lateral Distribution of Moment (exterior frame)

$M_1 = 0.26M_o$	74.42
$M_2 = 0.52M_o$	148.83
$M_3 = 0.70M_o$	200.35
$M_4 = 0.65M_o$	186.04
$M_5 = 0.35M_o$	100.18
All values are in ft.kip	

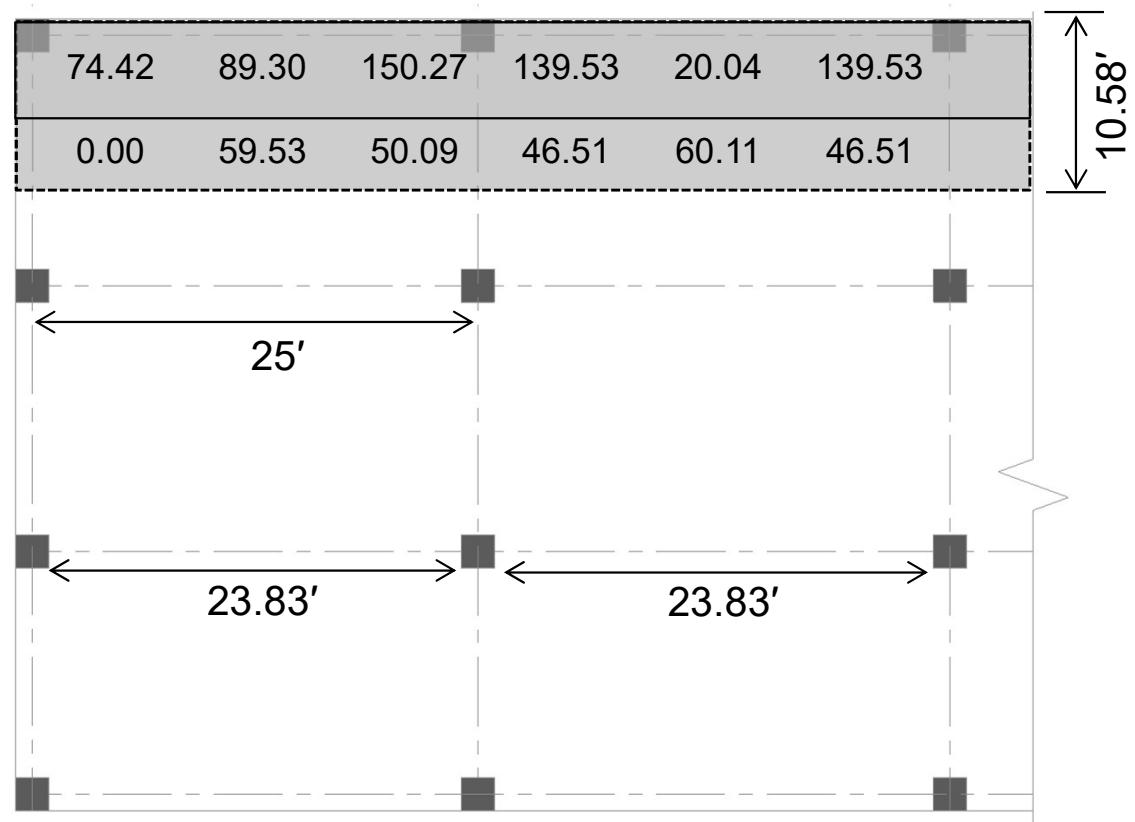



Example 5.1

□ Solution

➤ Step 3: Analysis (E-W Direction)

❖ Summary of Moments for Interior Frame

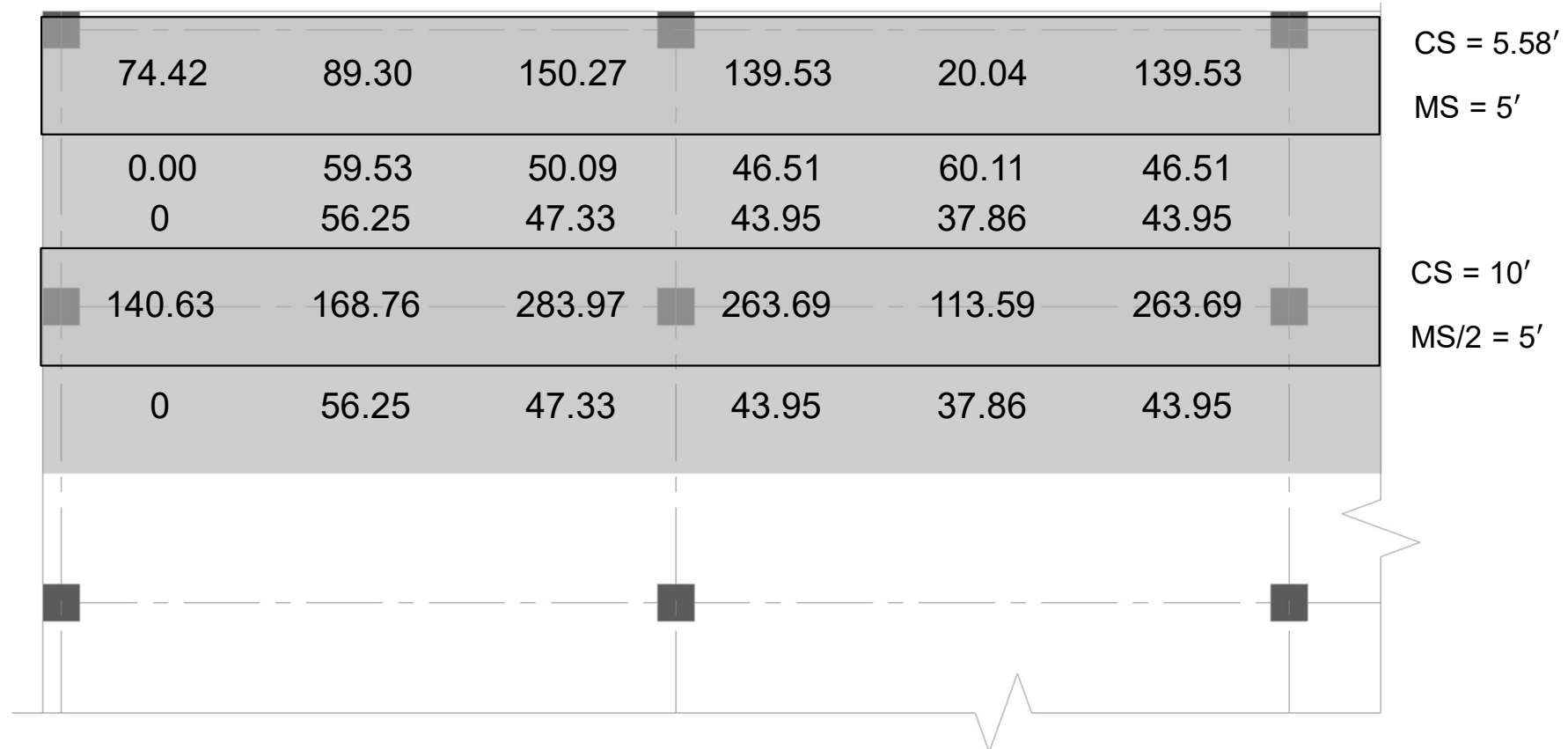



Example 5.1

□ Solution

➤ Step 3: Analysis (E-W Direction)

❖ Summary of Moments for Interior Frame (per unit strip)

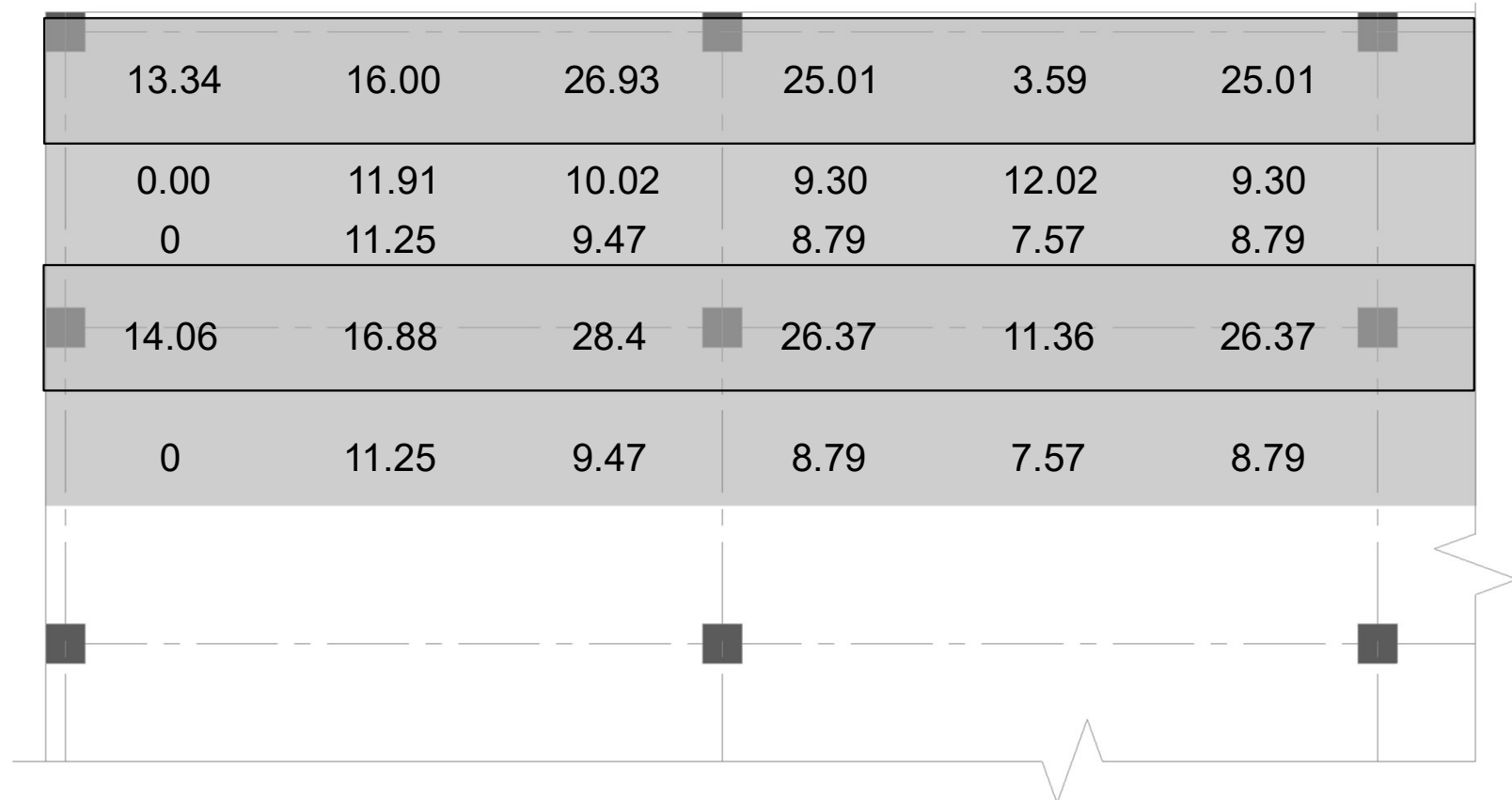



Example 5.1

□ Solution

➤ Step 3: Analysis (E-W Direction)

❖ Bending Moment Diagrams

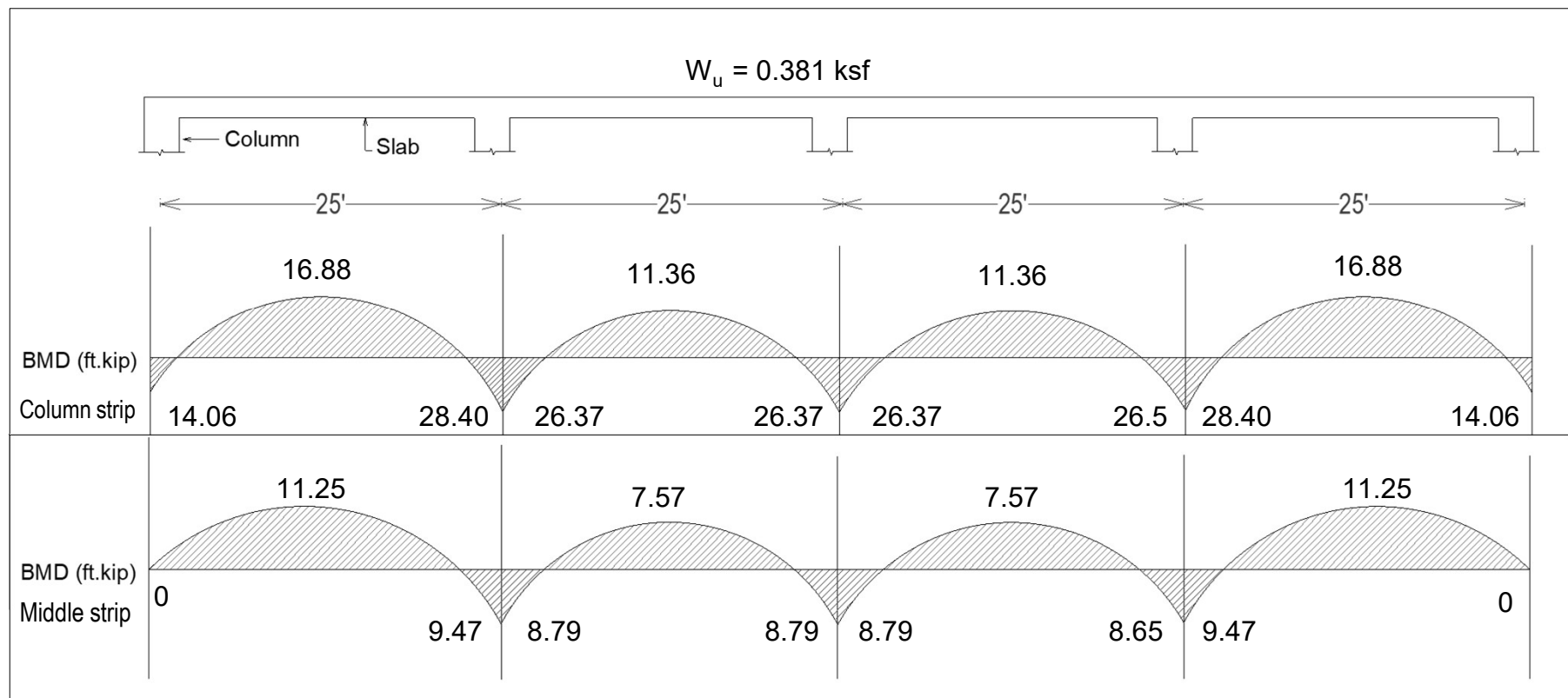



Example 5.1

□ Solution

➤ Step 3: Analysis (N-S Direction)

❖ Marking Frames and Strips

From figure, we have

$$l_1 = 20' , l_2 = 25'$$

$$l_n = 20 - \left(\frac{14}{12}\right) = 18.83'$$

Now,

$$CS = \frac{\min(l_1, l_2)}{2} = 10'$$

$$\frac{MS}{2} = (l_2 - CS)/2 = 7.5'$$

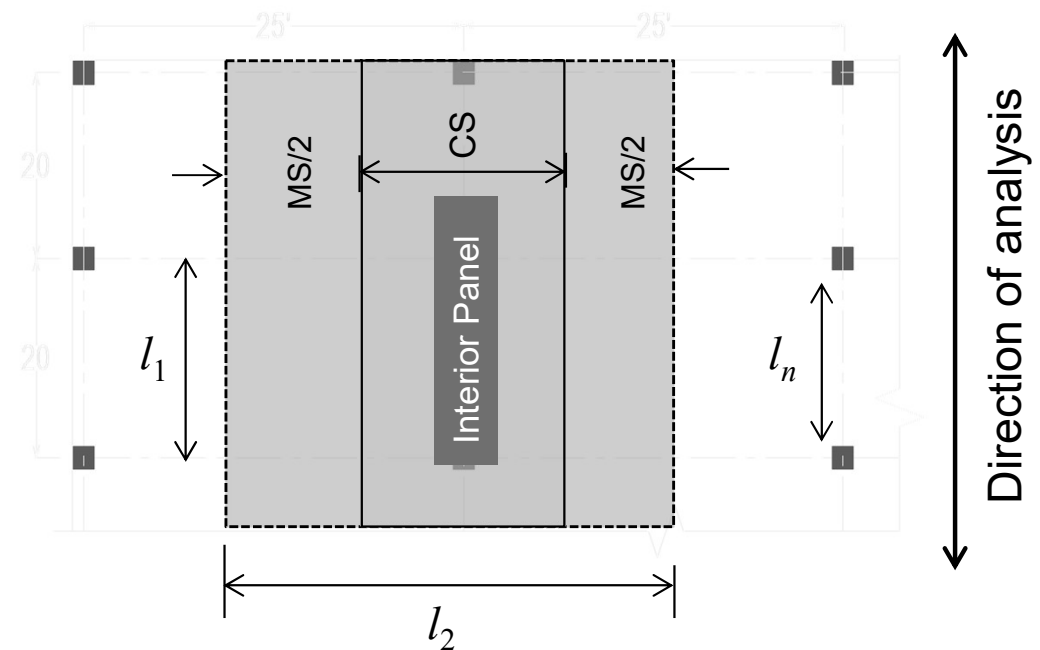



Example 5.1

□ Solution

➤ Step 3: Analysis (N-S Direction)

❖ Marking Frames and Strips

From figure, we have

$$l_2 = \frac{25}{2} + 0.5 \left(\frac{14}{12} \right) = 13.08'$$

$$l_n = 20 - \left(\frac{14}{12} \right) = 18.83'$$

Now,

$$CS = \frac{20}{4} + 0.5 \left(\frac{14}{12} \right) = 5.58'$$

$$MS = (l_2 - CS) / 2 = 7.5'$$

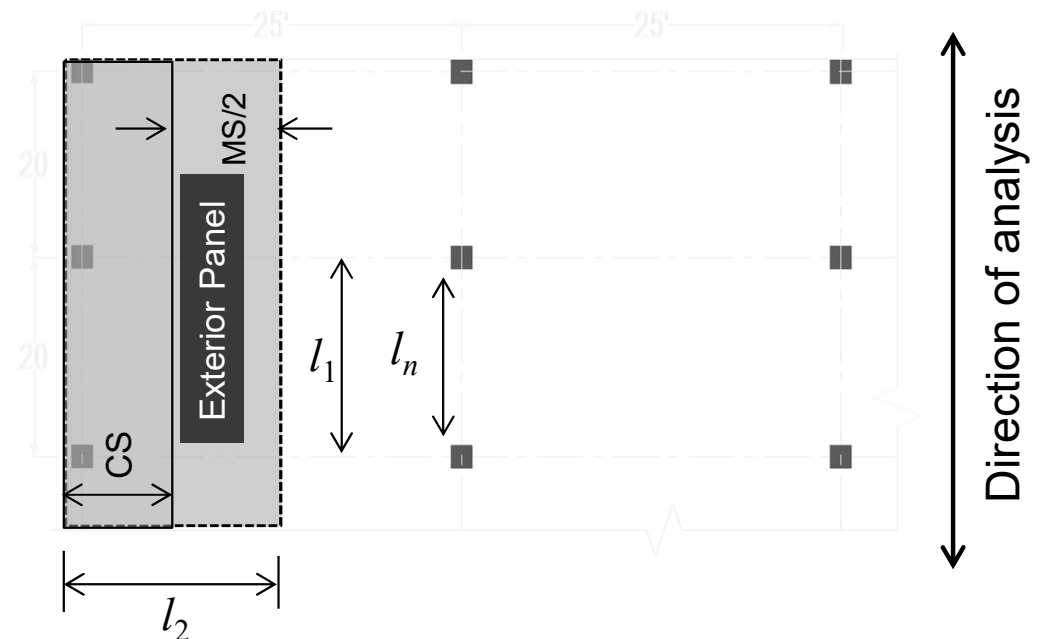



Example 5.1

□ Solution

➤ Step 3: Analysis (N-S Direction)

❖ Determination of Moments (interior frame)

- The same procedure is repeated to find moments in N-S direction.

Moments	Interior Frame $M_o = 422.16$	Exterior Frame $M_o = 220.93$
$M_1 = 0.26M_o$	109.76	57.44
$M_2 = 0.52M_o$	219.52	114.88
$M_3 = 0.70M_o$	295.51	154.65
$M_4 = 0.65M_o$	274.40	143.60
$M_5 = 0.35M_o$	147.76	77.33
All values are in ft.kip		



Example 5.1

□ Solution

➤ Step 3: Analysis (N-S Direction)

❖ Summary of Moments for Exterior Frame

57.44	0.00	0.00	109.76	0.00
68.93	45.95	43.90	131.71	43.90
115.99	41.42	36.94	221.63	36.94
107.70	35.90	34.30	205.80	34.30
46.40	30.93	29.55	88.65	29.55
107.70	35.90	34.30	205.80	34.30

CS = 5.58'
MS = 7.5'

CS = 10'
MS/2 = 7.5'



Example 5.1

□ Solution

➤ Step 3: Analysis (N-S Direction)

❖ Summary of Moments for Exterior Frame (per unit strip)

10.29	0.00	0	10.98	0
12.35	6.13	5.85	13.17	5.85
20.79	5.52	4.93	22.16	4.93
19.30	4.79	4.57	20.58	4.57
8.31	4.12	3.94	8.87	3.94
19.30	4.79	4.57	20.58	4.57



Example 5.1

□ Solution

➤ Step 3: Analysis (N-S Direction)

❖ Bending Moment Diagrams

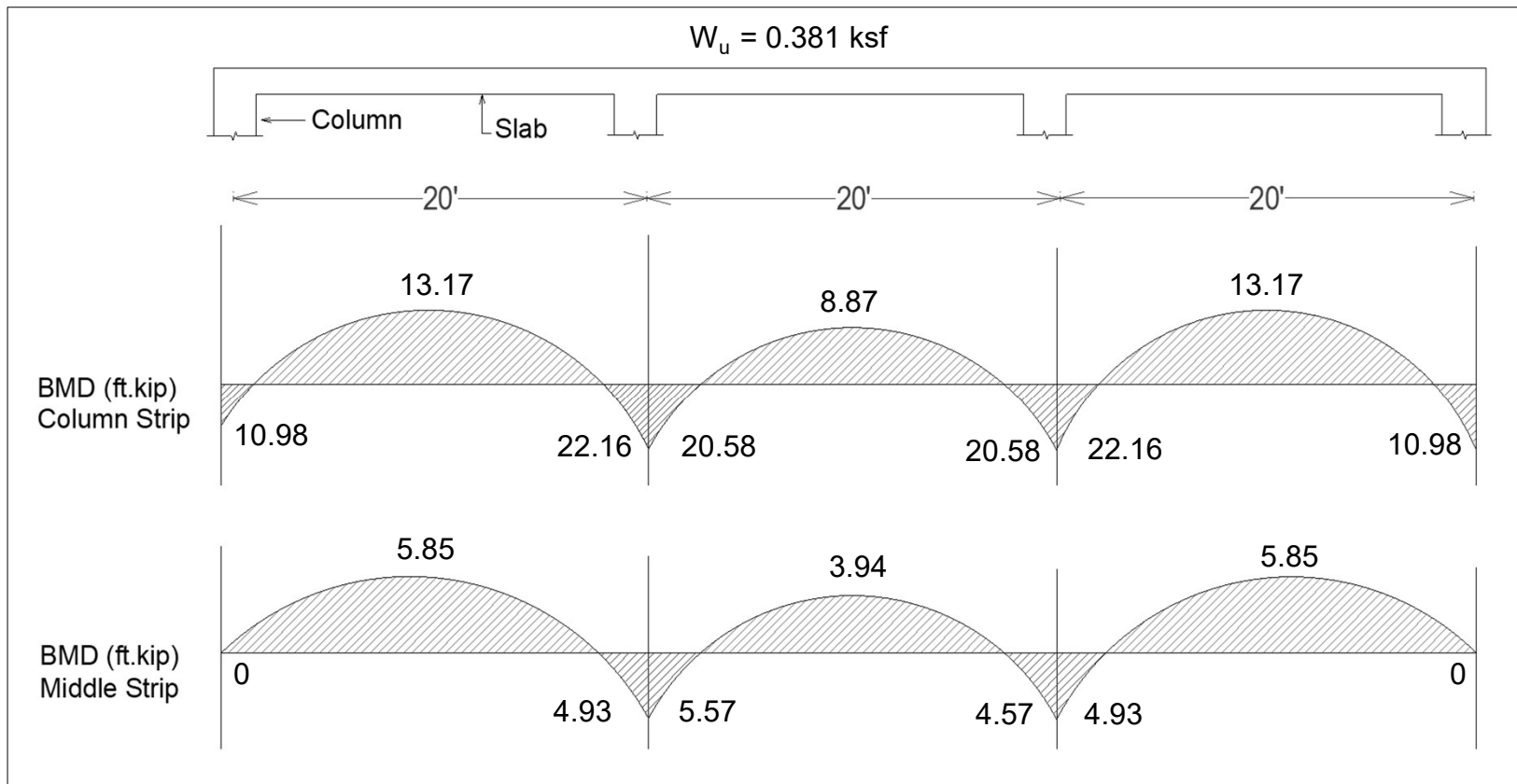



Example 5.1

□ Solution

➤ Step 4: Reinforcement Detailing (E-W Direction)

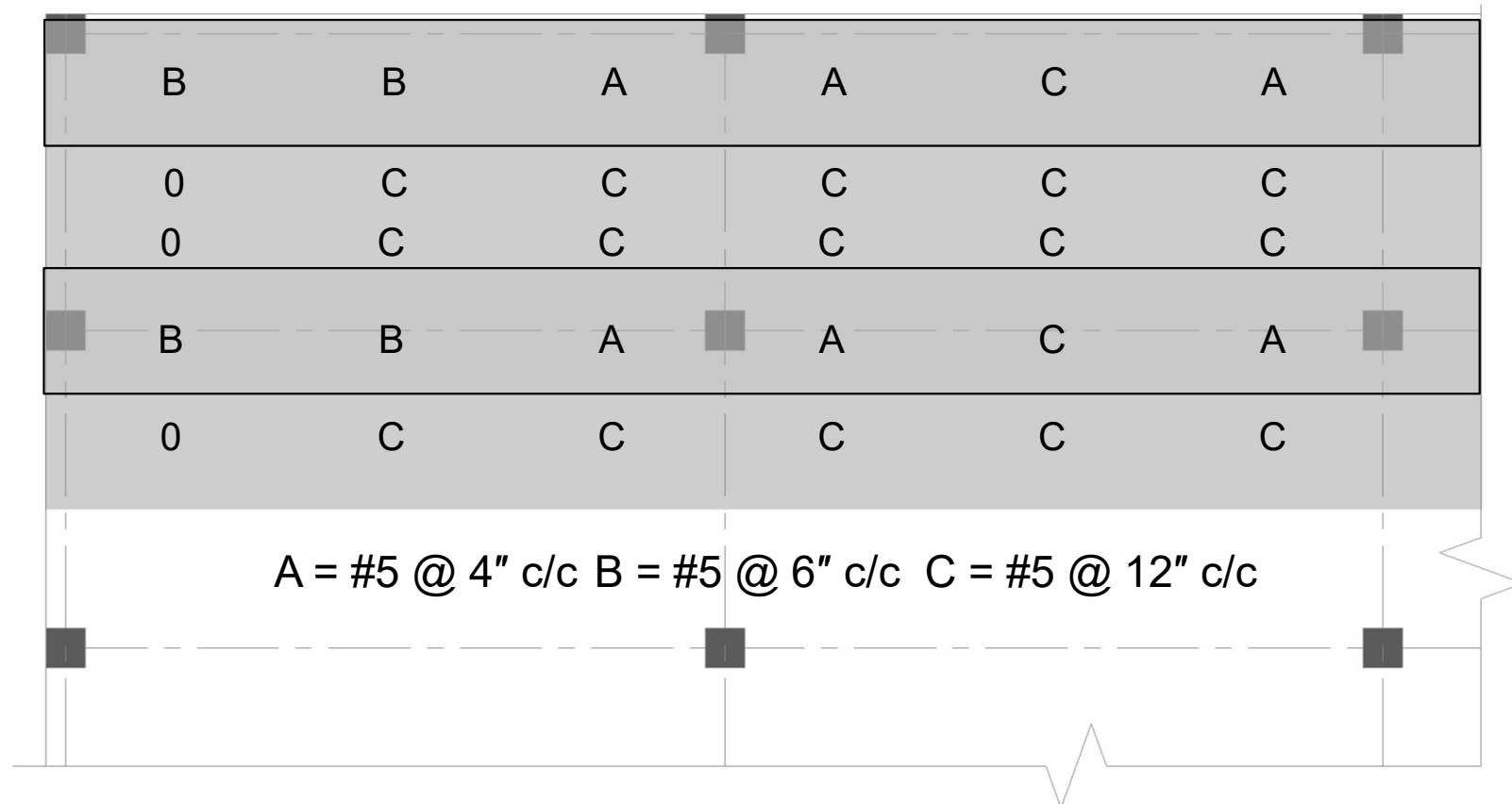



Example 5.1

□ Solution

➤ Step 4: Reinforcement Detailing (N-S Direction)

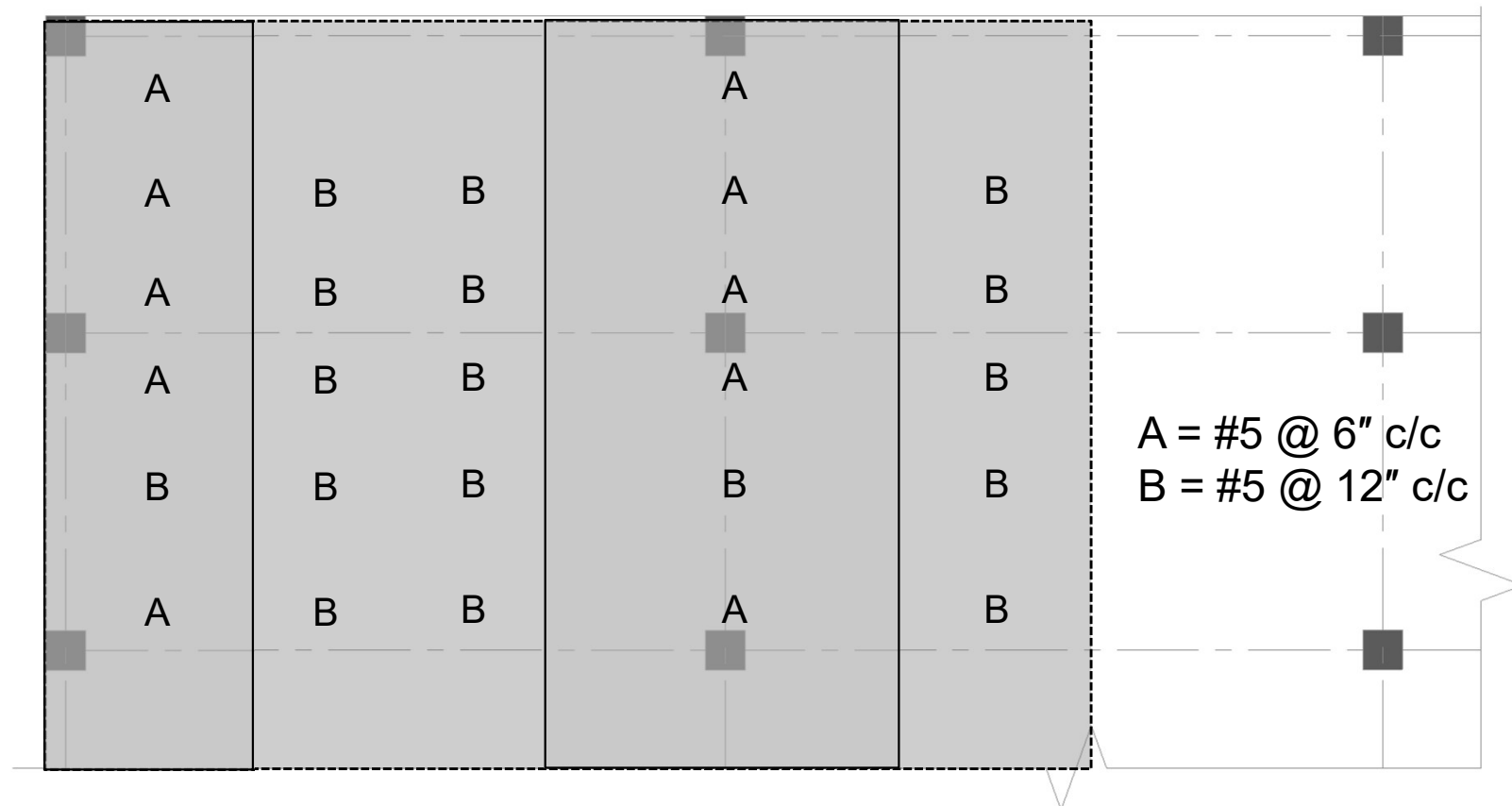



Other ACI Provisions for Flat Slabs

□ Reinforcement and Spacing Limits

❖ Minimum Reinforcement (ACI 24.4.3.2)

$$A_{s,min} = 0.0018 bh_s$$

❖ Maximum spacing (ACI 8.7.2.2)

$$S_{max} = 2h_s \text{ in each direction}$$



Other ACI Provisions for Flat Slabs

□ Detailing of Flexural Reinforcement

- In two-way slabs with beam supports, bars in shorter direction are placed closer to the surface due to greater moments in the shorter direction.
- However, for flat plates, long-direction bars in middle and column strips are placed nearer the surface due to larger moments in the longer direction.

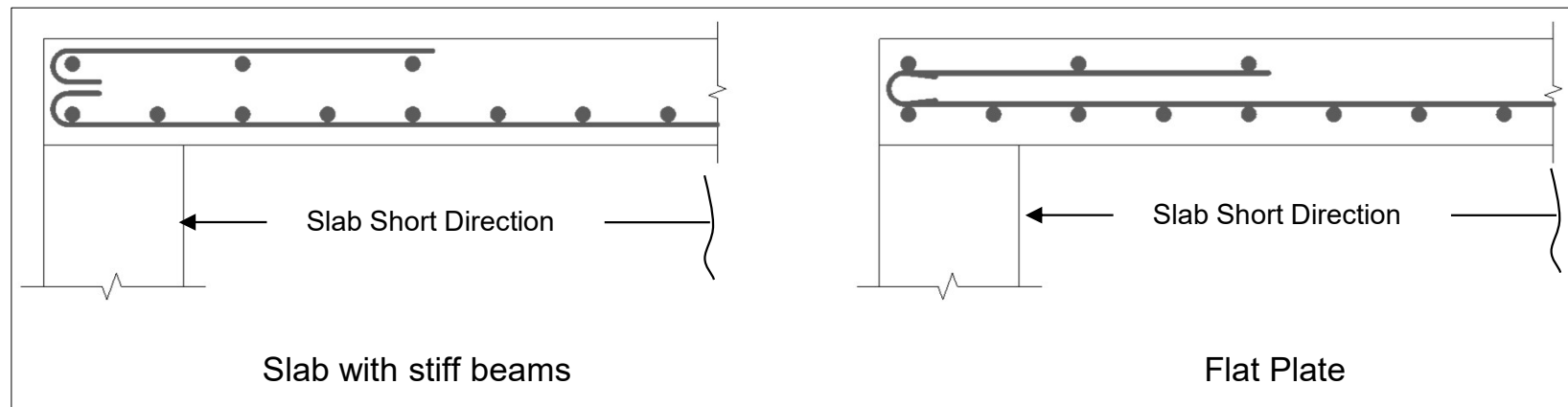



Other ACI Provisions for Flat Slabs

□ Detailing of Flexural Reinforcement

❖ Splicing

- ACI 8.7.4.2.1 requires that all bottom bars within the column strip in each direction be continuous or spliced with length equal to $1.0 l_d$, (For development length see ACI 25.4.2.3 or Nelson 13th Ed, page 172 chapter 5 or mechanical or welded splices).



Other ACI Provisions for Flat Slabs

□ Detailing of Flexural Reinforcement

❖ Continuity of Bars

- ACI 8.7.4.2.2 requires that at least two of the column strip bottom bars in each direction must pass within the column core and must be anchored at exterior supports.

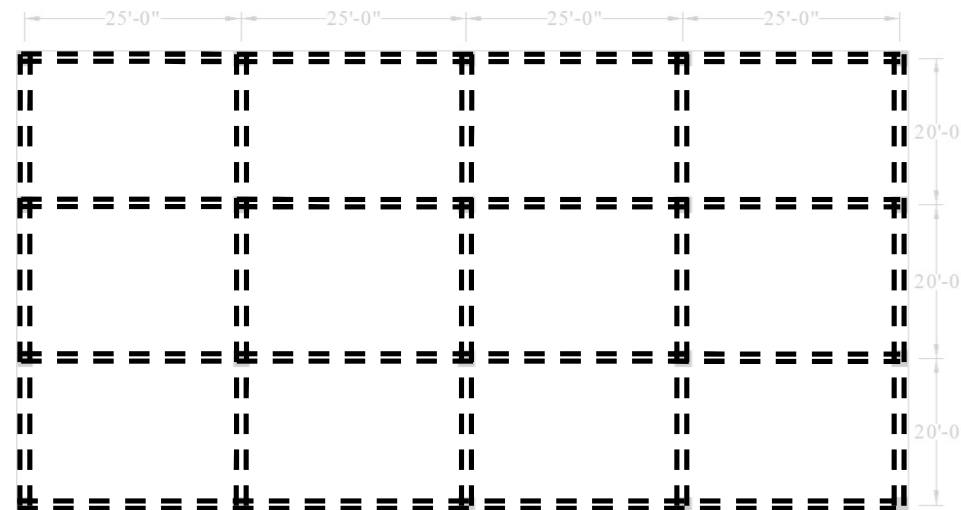



Other ACI Provisions for Flat Slabs

□ Detailing of Flexural Reinforcement

- Standard Bar Cut off Points (Practical Recommendation) for column and middle strips both are shown below.

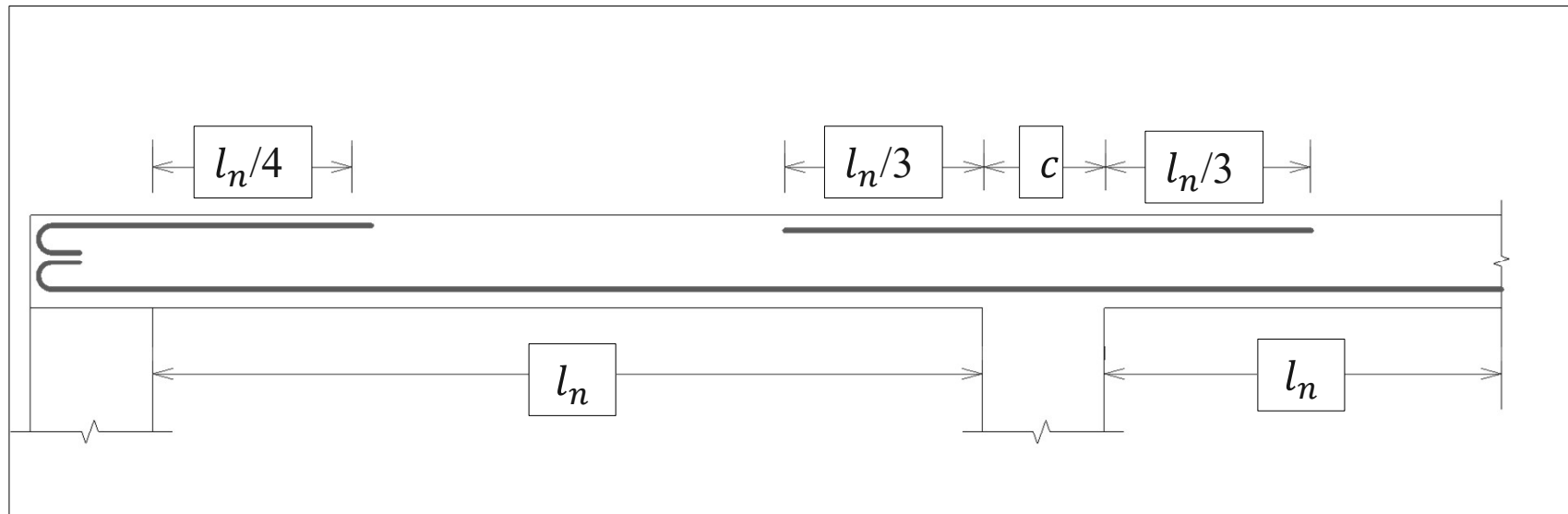



Other ACI Provisions for Flat Slabs

□ Detailing of Flexural Reinforcement

❖ Reinforcement at Exterior Corners

- ACI 8.7.3.1.2 mandates reinforcement at exterior corners on the top and bottom of the slab, extending one-fifth the longer span of the corner panel in both directions as shown in the figure.
- The positive and negative reinforcement should be of size and spacing equivalent to that required for maximum positive moments (per foot of width) in the panel.

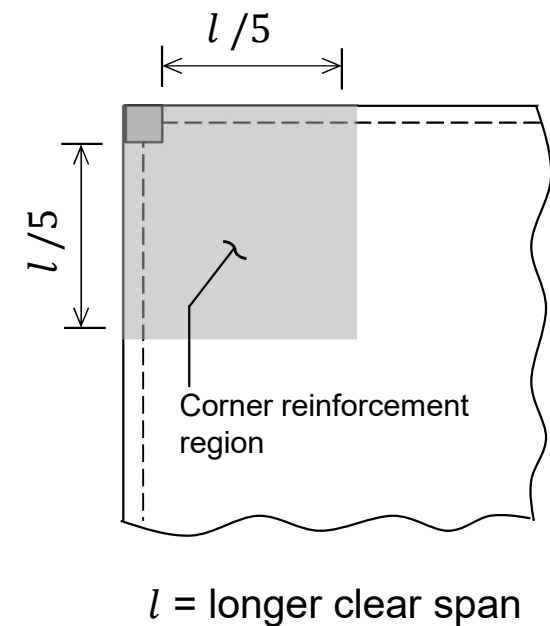



Other ACI Provisions for Flat Slabs

□ Detailing of Flexural Reinforcement

❖ Reinforcement at Exterior Corners

- There are two options available for providing corner reinforcement.

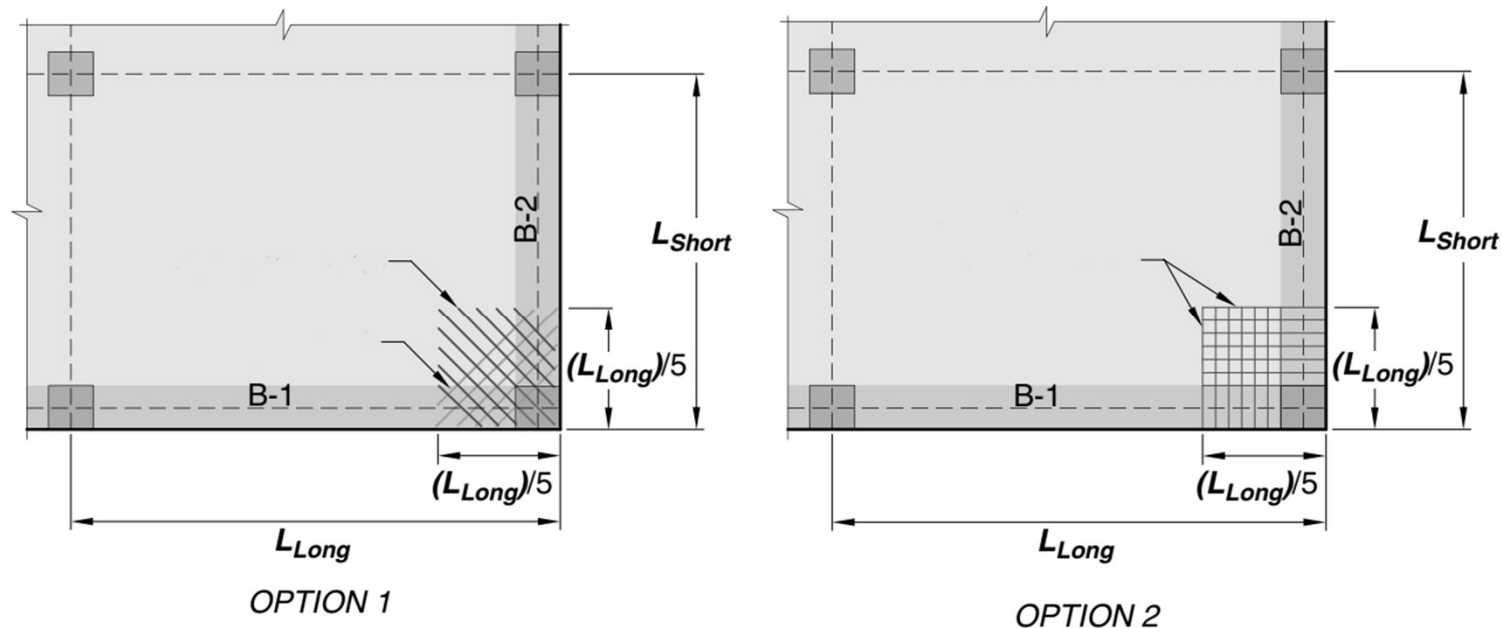

Slab Corner Reinforcement (ACI Fig. R8.7.3.1)



Section – II

Shear Design of Two-Way Slab System without Beams (Flat Plates and Flat Slabs)



General

□ Flat Plates and Flat Slabs

- These are the most common types of two-way slab system, which are commonly used in multi-story construction.
- They render low story heights and have easy construction and formwork.

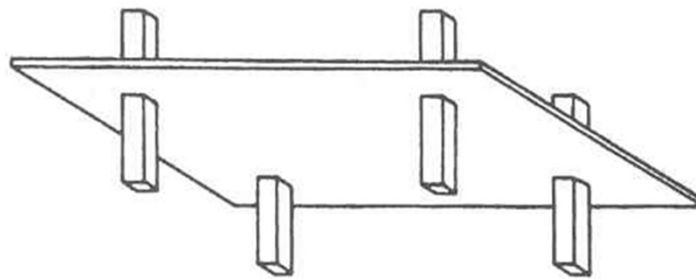

Flat Plate

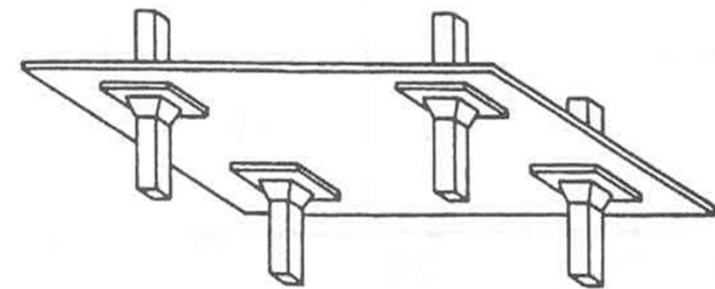

Flat Slab



General

□ Behavior

- These two-way slabs are directly supported by columns, shear near the column (punching shear) is of critical importance.
- Therefore, in addition to flexure, flat plates shall also be designed for two-way shear (punch out shear) stresses.



General

□ Punching Shear in Flat Plates

- Punching shear occurs at column support points in flat plates and flat slabs.

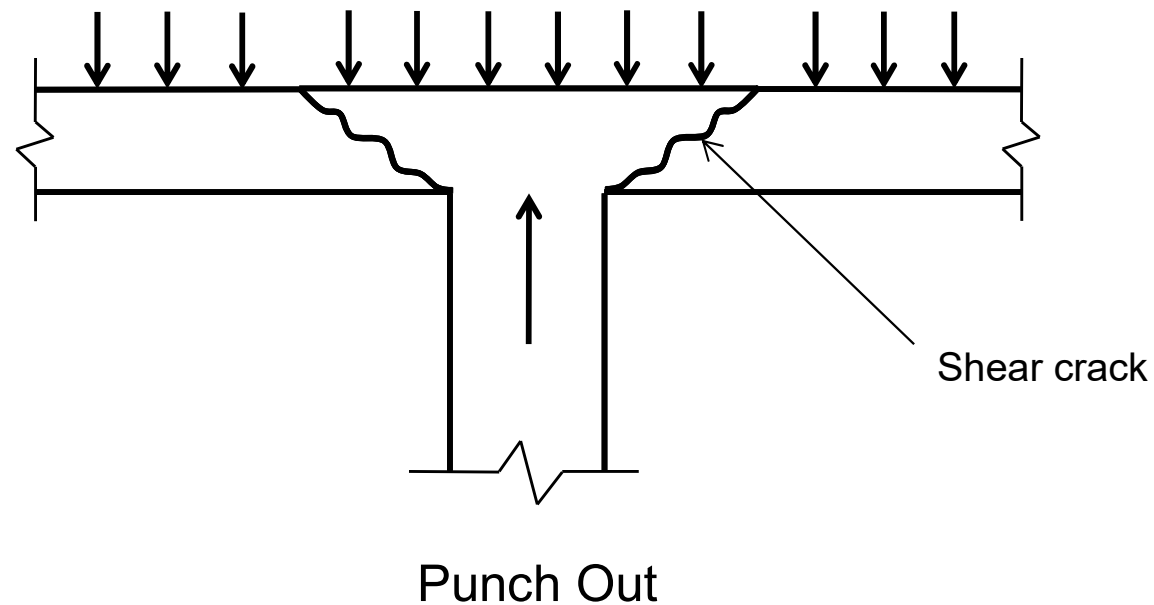



General

❑ Critical Section for Punching Shear

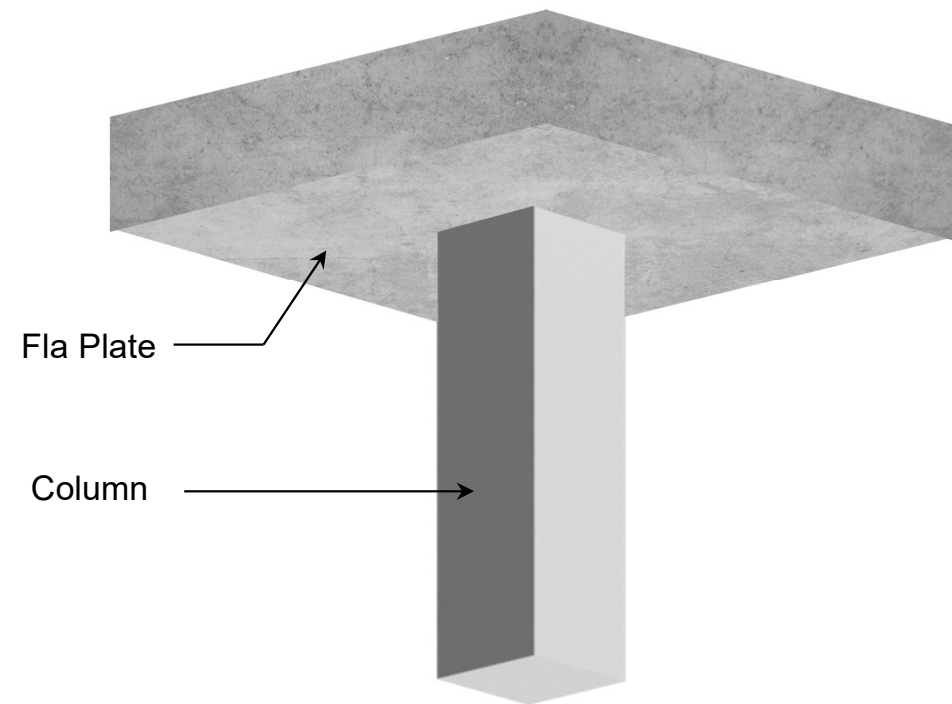
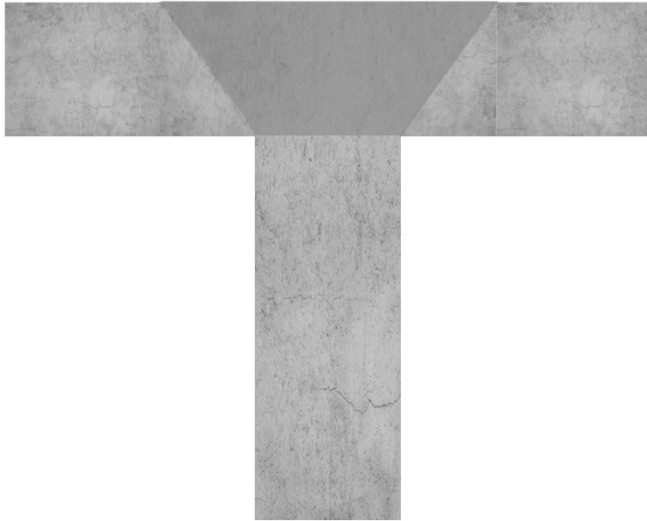



General

❑ Critical Section for Punching Shear

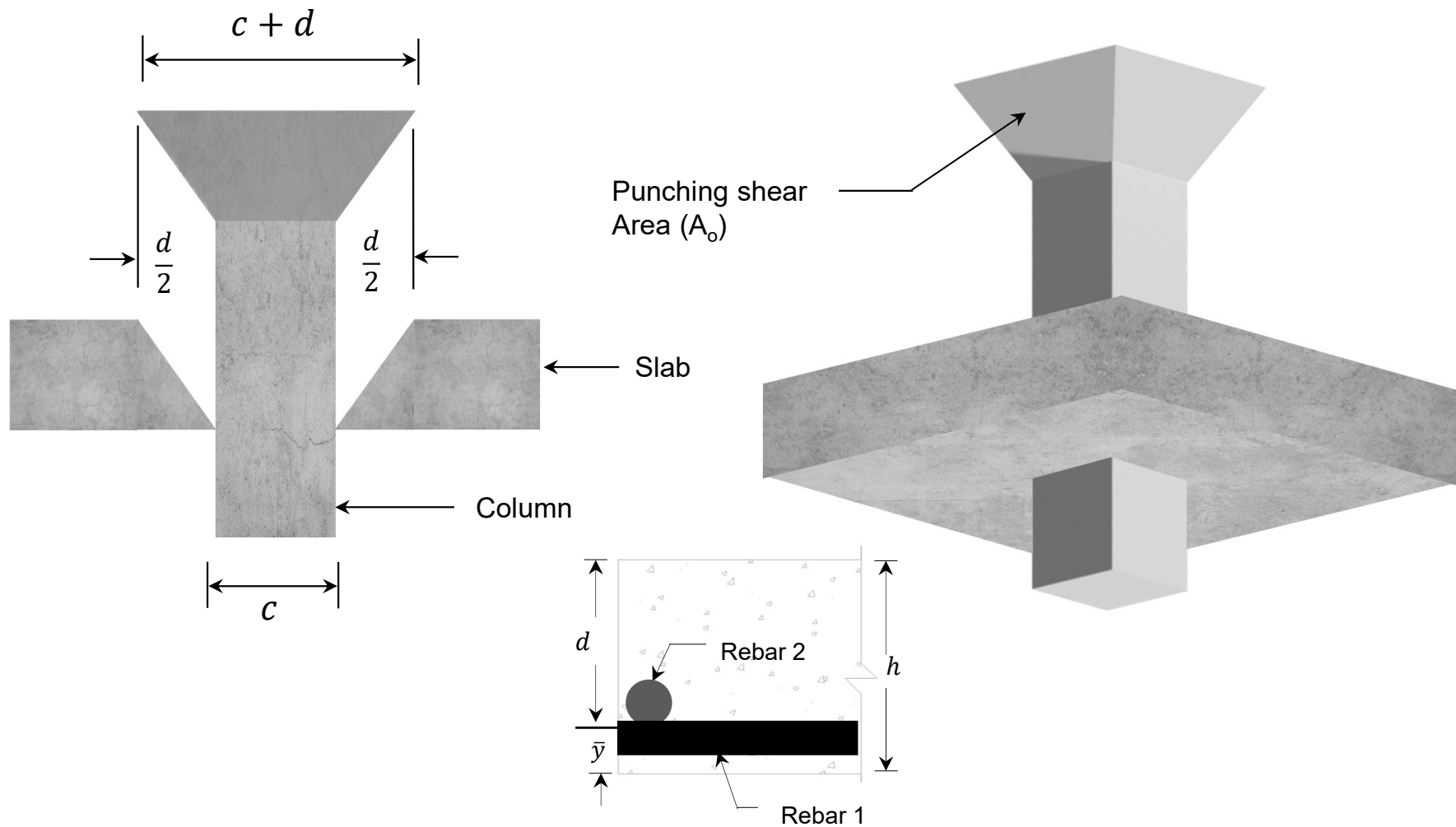



General

❑ Critical Section for Punching Shear

- In shear design of flat plates, the critical section is an area taken at a distance “ $d/2$ ” from all face of the support.

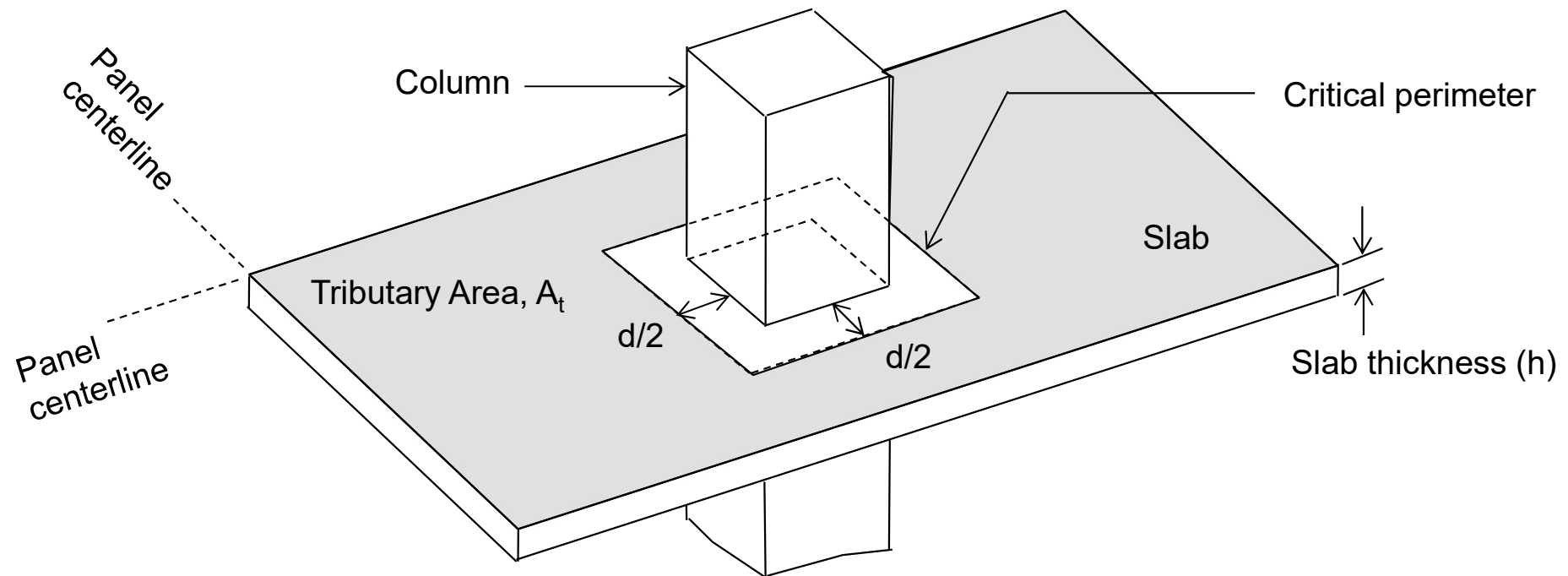



General

□ Calculation of Critical Perimeter b_o

❖ Interior Columns

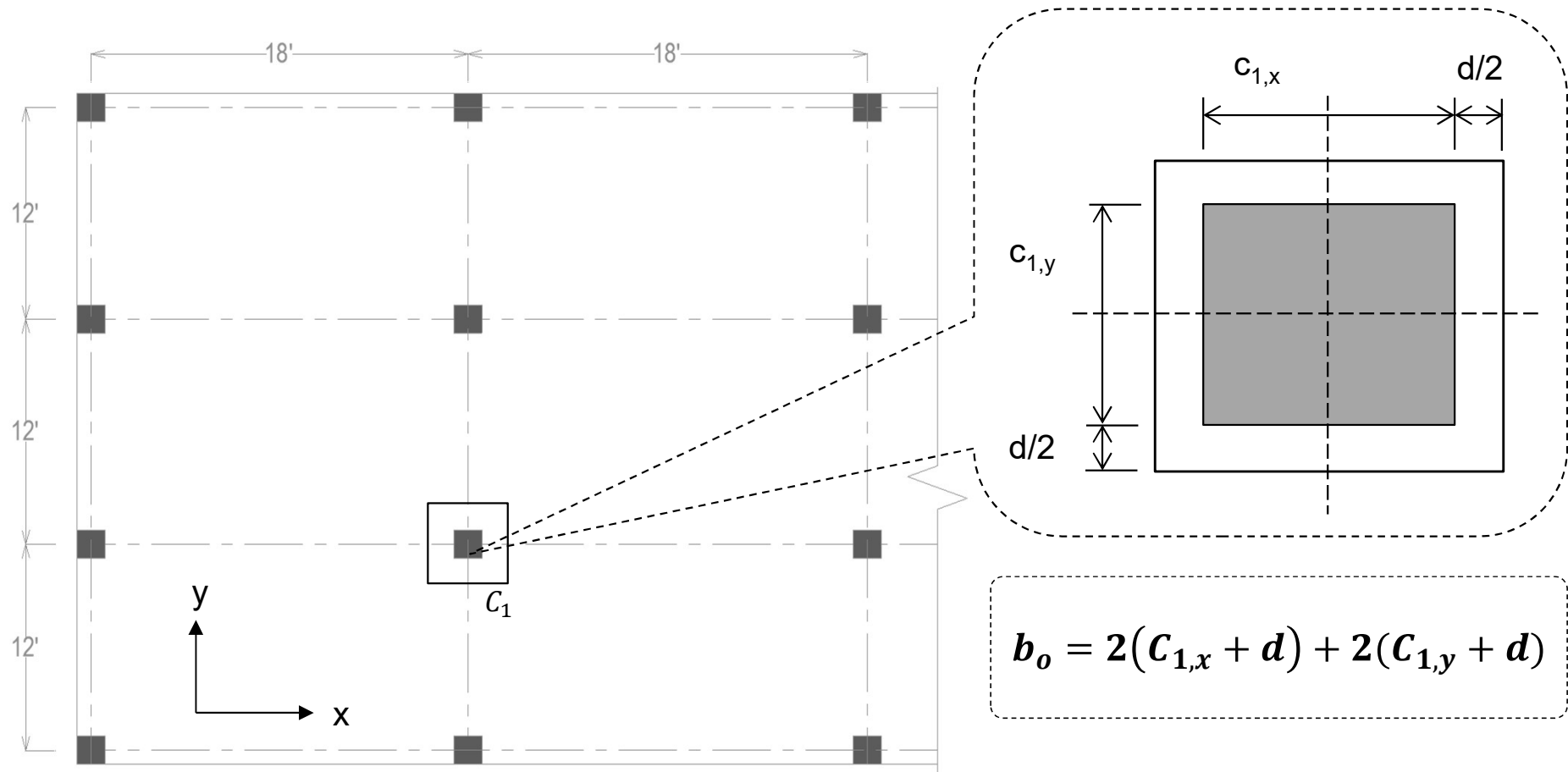



General

□ Calculation of Critical Perimeter b_o

❖ Edge Columns

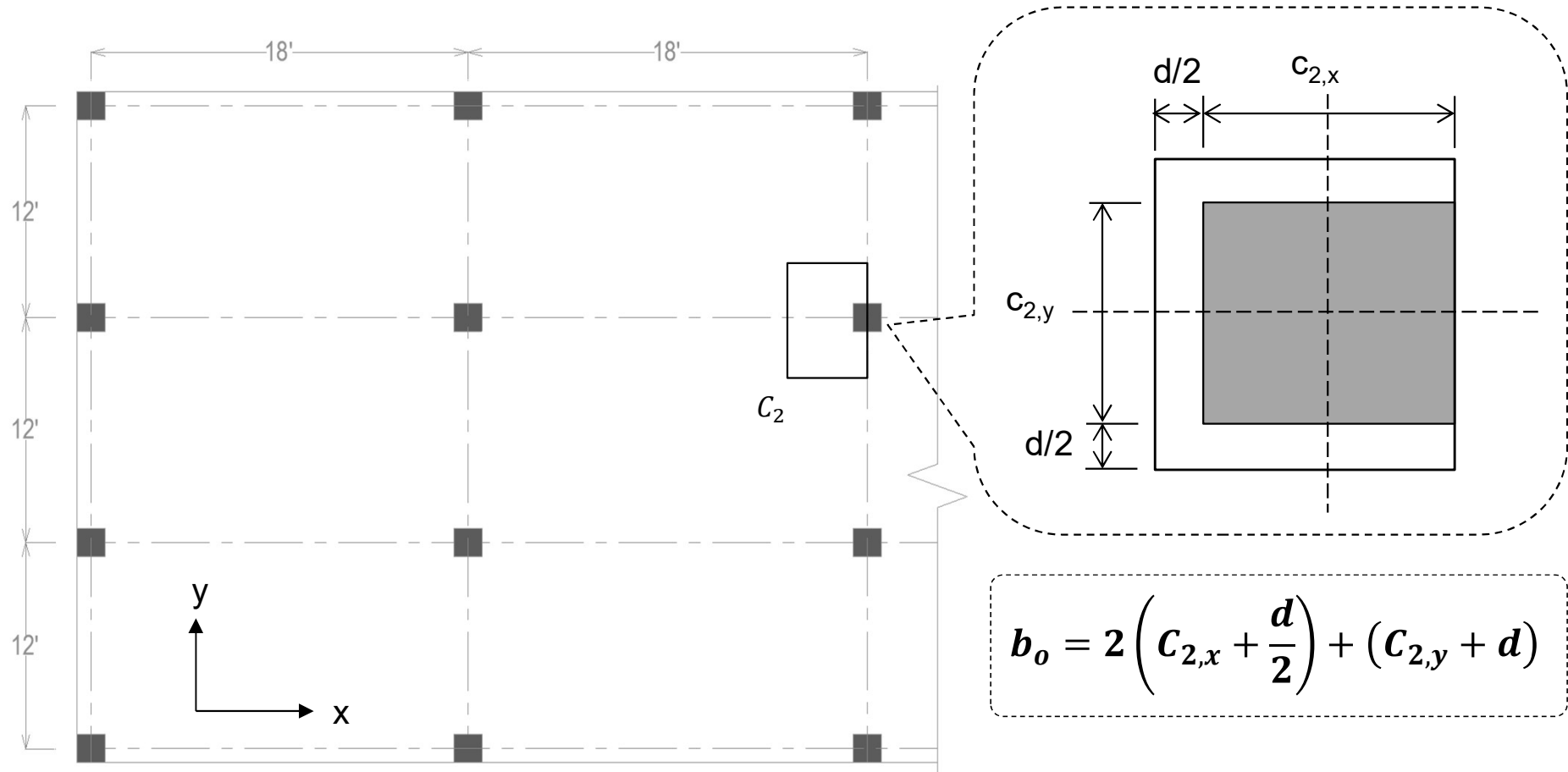



General

□ Calculation of Critical Perimeter b_o

❖ Corner Columns

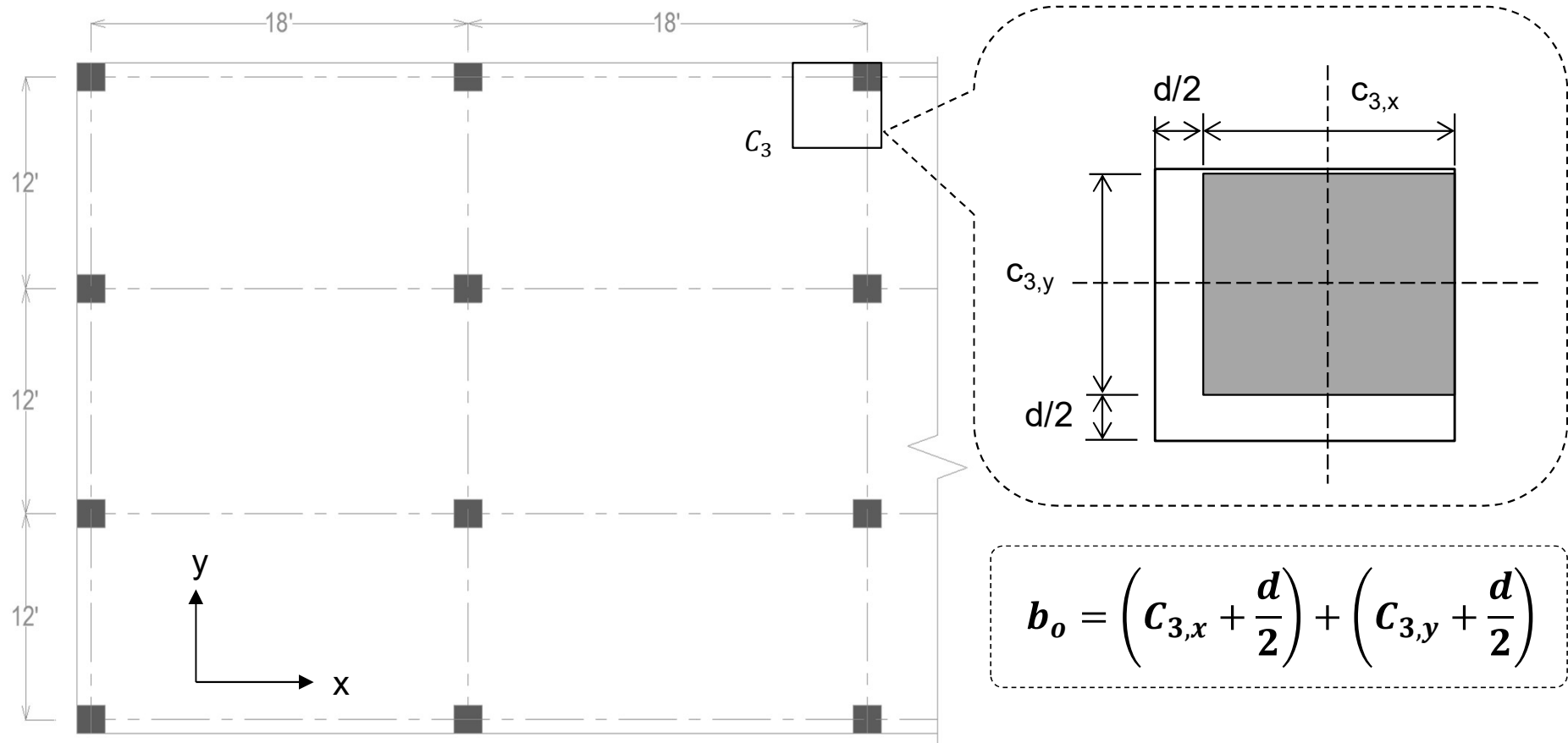



General

□ Punching Shear Demand V_u for Square Columns

- Punching shear demand for square columns can be determined using the following steps.

1. Calculate Tributary Area

$$A_t = l_1 \times l_2 - A_o$$

where;

$$A_o = (c + d)^2 \rightarrow \text{for square columns}$$

$$A_t = l_1 l_2 - (c + d)^2 / 144$$

[l_1 & l_2 are in ft. and c & d are in inches]

2. Calculate Demand V_u

$$V_u = w_u A_t$$

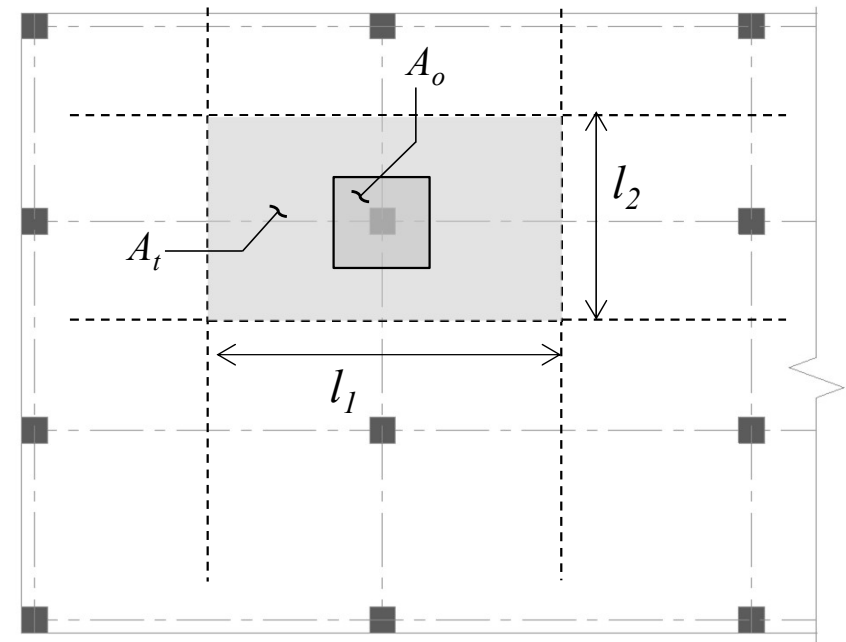



General

□ Capacity of Slab in Punching Shear

The total punching shear capacity is given by

$$\phi V_n = \phi V_c + \phi V_s$$

ϕV_c calculated from ACI Table 22.6.5.2, is the least of:

$$V_c = \min \left(4, 2 + \frac{4}{\beta_c}, \frac{\alpha_s d}{b_o} + 2 \right) \phi \lambda_s \sqrt{f'_c} b_o d$$

Where;

β_c = longer side of column/shorter side of column

α_s = 40 for interior column, 30 for edge column, 20 for corner columns

λ_s = size effect factor that can be determined as per 22.5.5.1.3

$$\lambda_s = \sqrt{\frac{2}{1 + d/10}} \leq 1$$



Design of Slabs for Punching Shear

□ Various Design Options

- When $\Phi V_c \geq V_u$ ($\Phi = 0.75$) \rightarrow nothing is required.
- When $\Phi V_c < V_u$, \rightarrow increase the punching shear capacity of the slab.
- Various options are available for increasing the punching shear capacity as described next.



Design of Slabs for Punching Shear

□ Various Design Options

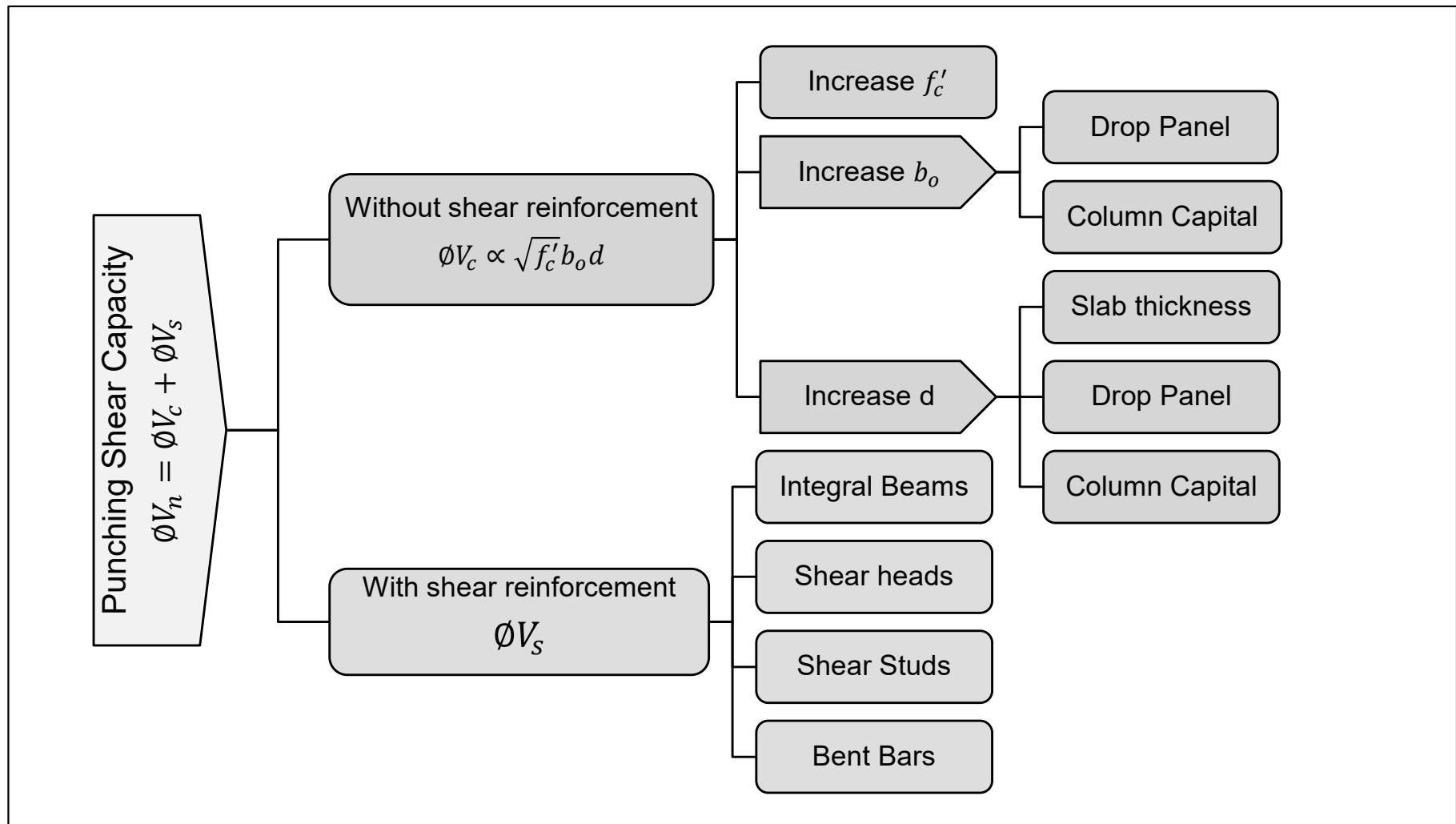



Design of Slabs for Punching Shear

□ Punching Shear Design without Shear Reinforcement

❖ Drop Panel

- A drop panel is the projection of slab provided at the vicinity of column to minimize punching shear demand.





Design of Slabs for Punching Shear

❑ Punching Shear Design without Shear Reinforcement

❖ Drop Panel

- ACI Section 8.2.4 requires that drop panel shall:
 - a) Project below the slab at least one-fourth of the adjacent slab thickness.
 - b) Extend in each direction from the centerline of support a distance not less than one-sixth the span length measured from center-to-center of supports in that direction.

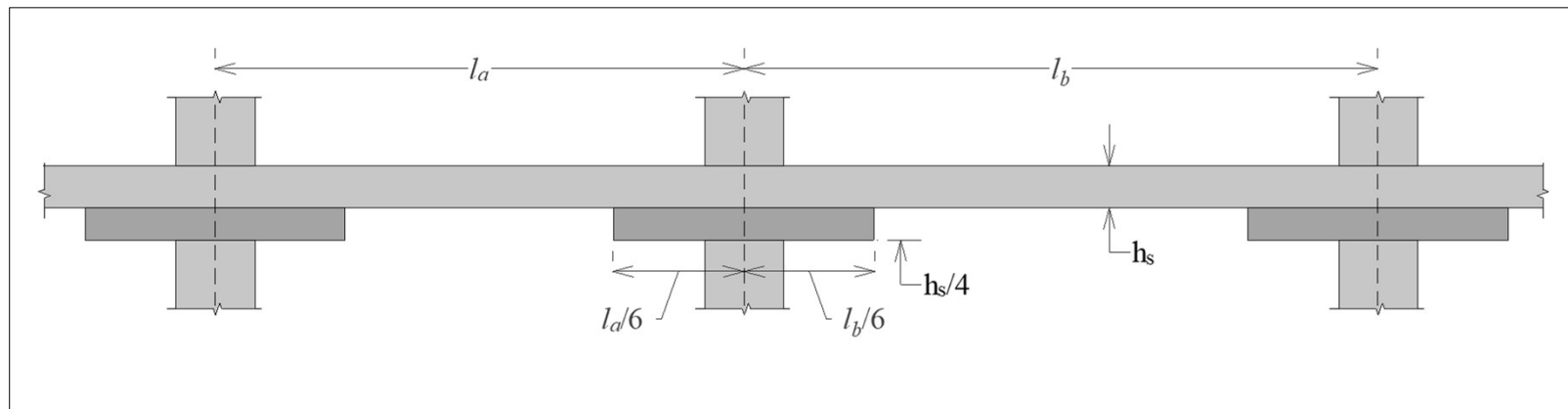



Design of Slabs for Punching Shear

□ Punching Shear Design without Shear Reinforcement

❖ Column Capital

- Column capital is the enlargement of the top of a concrete column located directly below the slab or drop panel that is cast monolithically with the column (ACI 2.2).

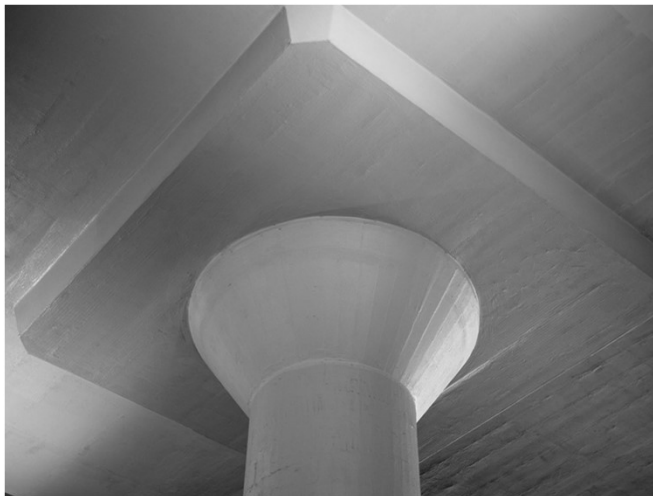



Design of Slabs for Punching Shear

❑ Punching Shear Design without Shear Reinforcement

❖ Column Capital

- ACI Section 8.4.1.4 requires the column capital should be oriented no greater than 45° to the axis of the column ($\theta \leq 45^\circ$).

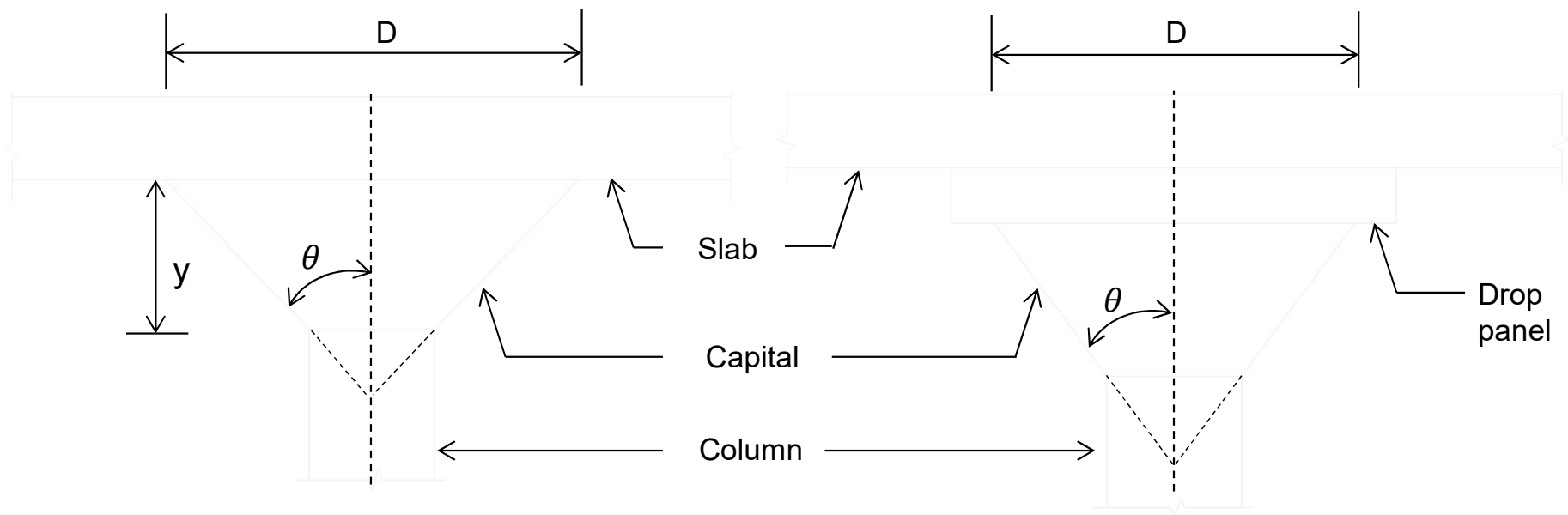



Design of Slabs for Punching Shear

□ Punching Shear Design without Shear Reinforcement

❖ Column Capital

- ACI Section 26.5.7 (d) requires that the concrete be placed at the same time as the slab concrete. As a result, the floor forming becomes considerably more complicated and expensive.
- The increased perimeter can be computed by equating V_u to ϕV_c and simplifying the resulting equation for b_o .



Design of Slabs for Punching Shear

□ Punching Shear Design with Shear Reinforcement

- The shear reinforcement can be provided by any of the following methods.

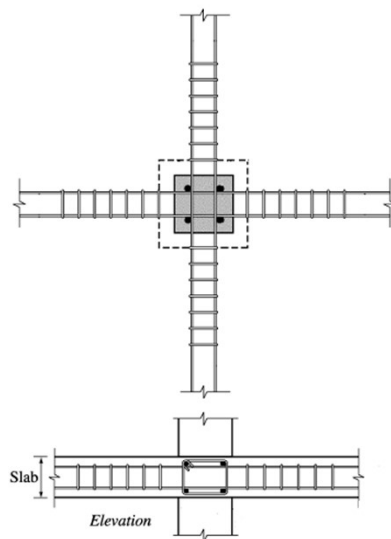

Integral Beams

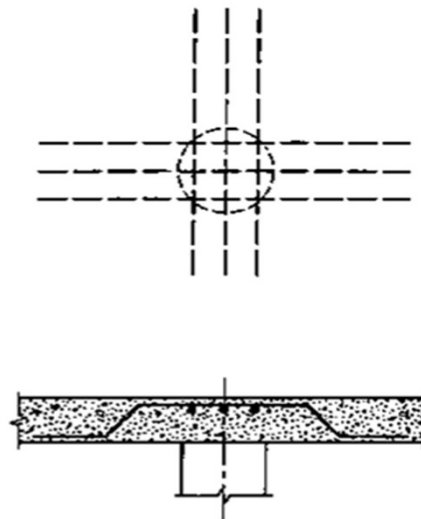

Integral Beams

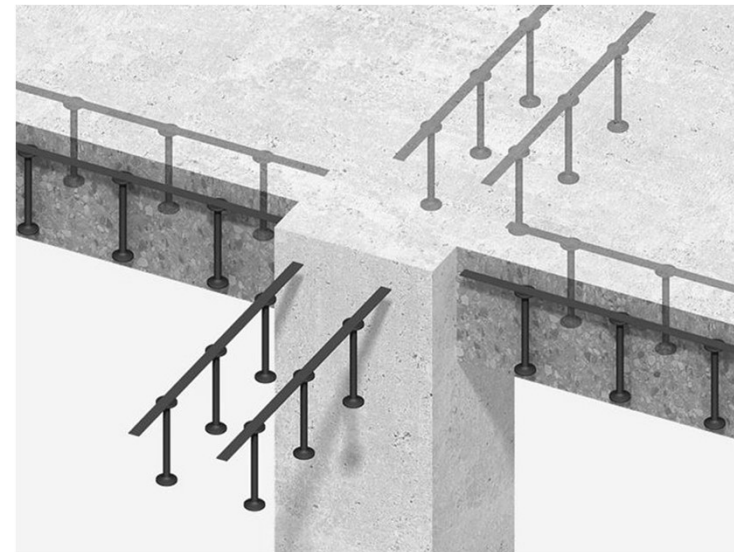

Shear Studs

- Only the design of Integral beams will be discussed next.



Design of Slabs for Punching Shear

□ Punching Shear Design with Shear Reinforcement

❖ Integral Beams

- For integral beams or bent bar reinforcement following must be satisfied.
 - i. The slab effective depth d to be at least 6 in., but not less than 16 times the diameter of the shear reinforcement (ACI 26.6.7.1).
 - ii. When bent bars and integral beams are to be used, reduce ΦV_c by 2 (ACI R22.6.6.1).

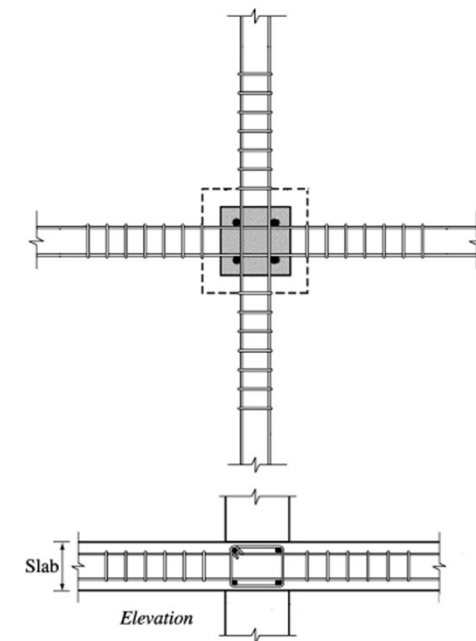



Design of Slabs for Punching Shear

□ Punching Shear Design with Shear Reinforcement

❖ Integral Beams

- Integral Beams require the design of two main components:
 1. Vertical stirrups
 2. Horizontal bars radiating outward from column faces.

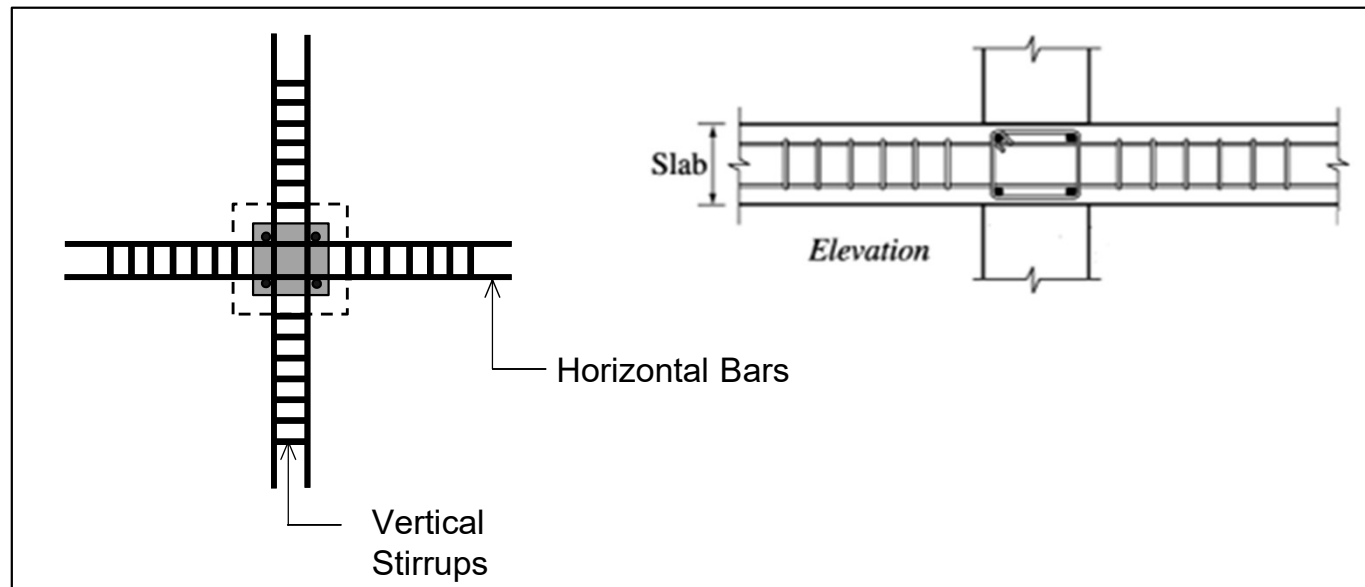



Design of Slabs for Punching Shear

□ Punching Shear Design with Shear Reinforcement

❖ Integral Beams

1. Vertical Stirrups

- Vertical stirrups are used in conjunction with supplementary horizontal bars radiating outward in two perpendicular directions from the support to form what are termed integral beams contained entirely within the slab thickness.
- In such a way, critical perimeter is increased as illustrated next.



Design of Slabs for Punching Shear

□ Punching Shear Design with Shear Reinforcement

❖ Integral Beams

1. Vertical Stirrups

- Stirrups are placed vertically on all four sides, resulting in a total stirrup area that equals four times the area of each individual two-legged stirrup.

$$A_v = 4(2A_b) = 8A_b$$

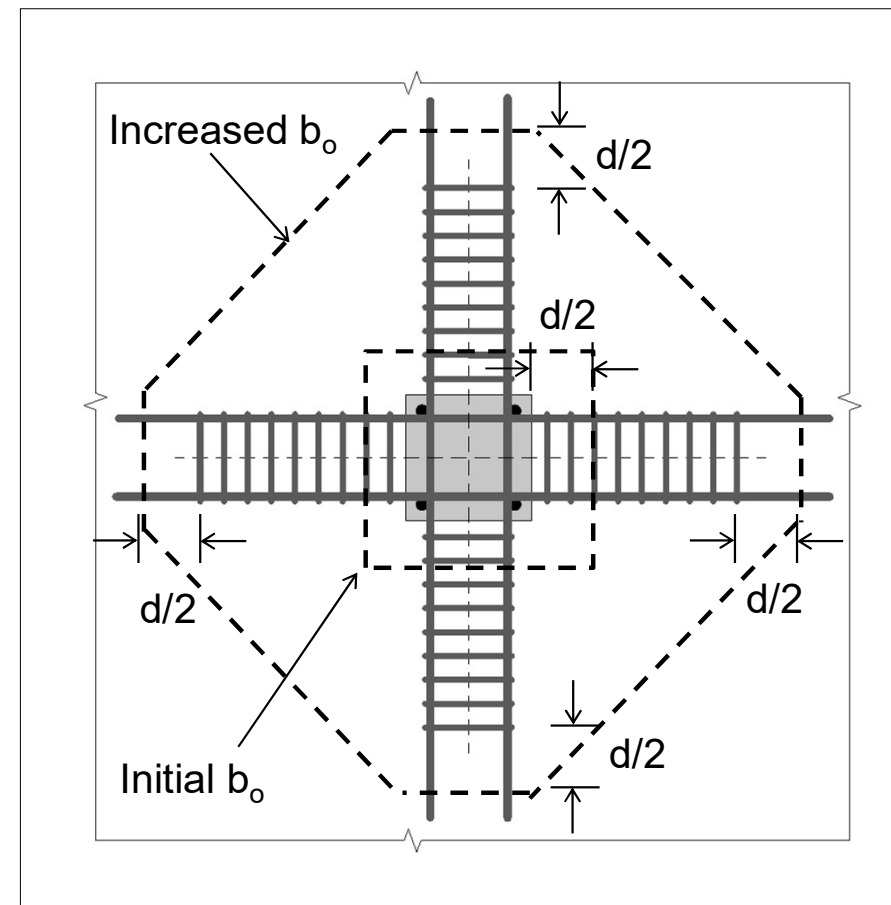



Design of Slabs for Punching Shear

□ Punching Shear Design with Shear Reinforcement

❖ Integral Beams

2. Horizontal Bars

- The length of horizontal bars l_v from the center of column can be determined using critical perimeter b_o .
- For square column of size “c”, we have

$$b_o = 4R + 4c \quad \text{--- (A)}$$

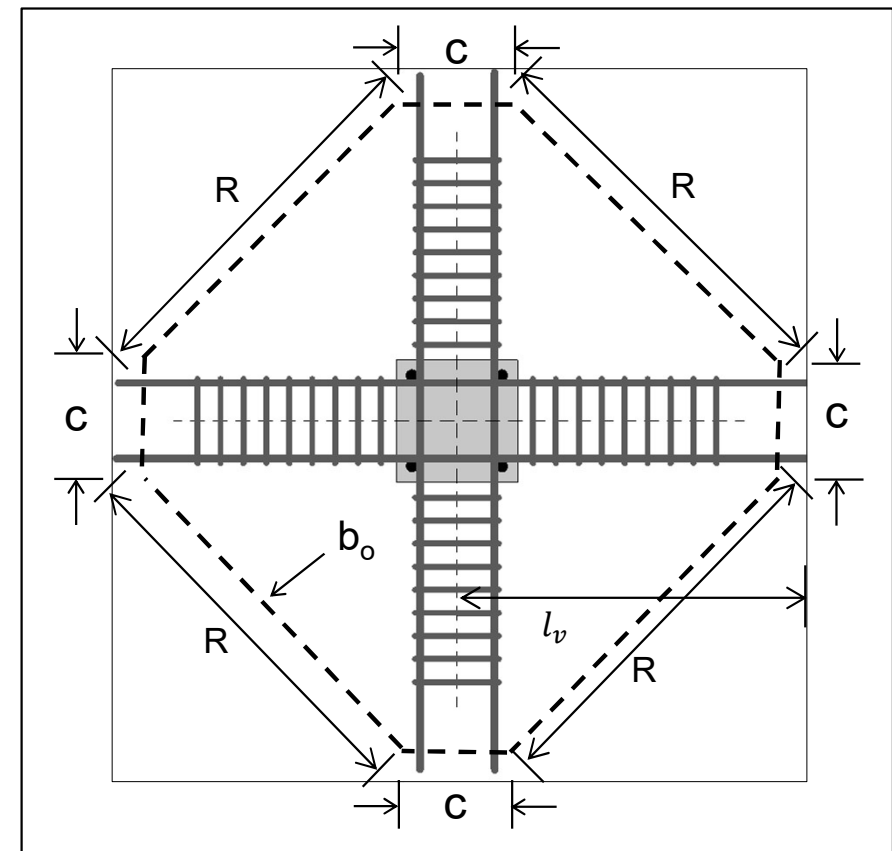



Design of Slabs for Punching Shear

□ Punching Shear Design with Shear Reinforcement

❖ Integral Beams

2. Horizontal Bars

- The projection from the face of column to the boundary of critical perimeter x is:

$$x = \frac{3}{4} \left(l_v - \frac{c}{2} \right)$$

From the shaded triangle

$$R = \sqrt{x^2 + x^2} = \sqrt{2} x$$

$$R = \sqrt{2} \left[\frac{3}{4} \left(l_v - \frac{c}{2} \right) \right]$$

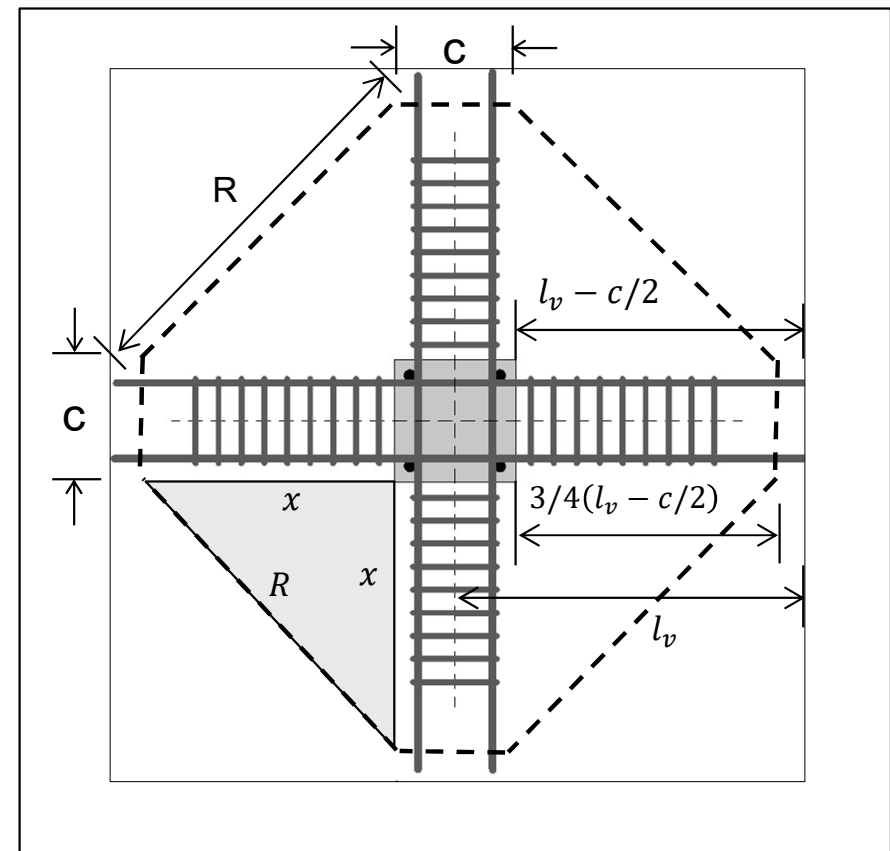



Design of Slabs for Punching Shear

□ Punching Shear Design with Shear Reinforcement

❖ Integral Beams

2. Horizontal Bars

Substituting the value in equation (A), we get

$$b_o = 4R + 4c = 4 \left[\sqrt{2} \times \frac{3}{4} \left(l_v - \frac{c}{2} \right) \right] + 4c = 4.24l_v + 1.88c$$

Solving for l_v , we get

$$l_v = \frac{b_o - 1.88c}{4.24}$$

This equation can be used for determining the length up to which the horizontal bars should be extended beyond the face of column. The b_o can be obtained by equating V_u with ϕV_c and solving the resulting equation for b_o .



Example 5.2

□ Problem Statement

- A 10-inch-thick flat plate shown below supports a uniformly distributed factored load (including self weight of plate) of 0.381 ksf. **Design** the plate for punching shear using various options. Take $f'_c = 4$ ksi and $f_y = 60$ ksi.



All columns are 14" square



Example 5.2

□ Solution

➤ Step 1: Calculation of Punching Shear Demand V_u

The punching shear demand V_u can be calculated as follows

$$V_u = w_u \times A_t$$

$$A_t = l_1 l_2 - \frac{(c + d)^2}{144}$$

Assuming #6 bar ;

$$d = h_s - 0.75 - 0.75 = 8.5''$$

$$A_t = 25 \times 20 - \frac{(14 + 8.5)^2}{144} = 496.48 \text{ ft}^2$$

$$V_u = w_u \times A_t = 0.381 \times 496.48 = \mathbf{189.16 \text{ kip}}$$

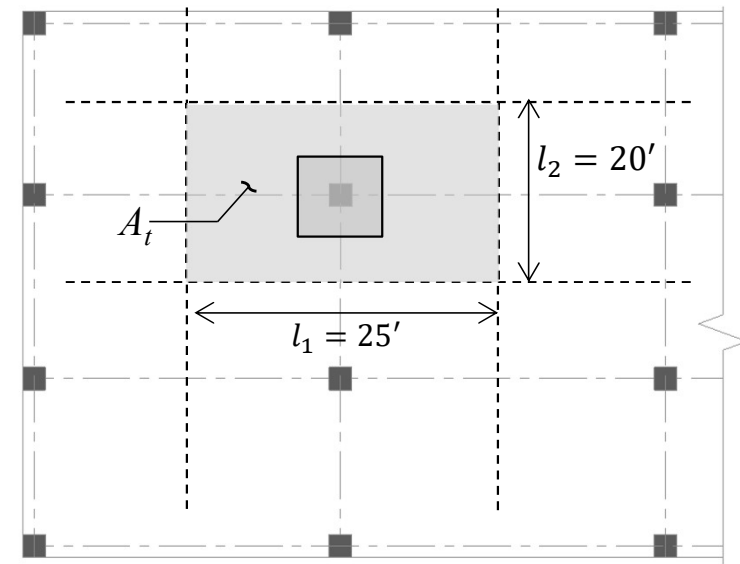



Example 5.2

□ Solution

➤ Step 2: Calculation of Punching Shear Capacity

The design punching shear capacity of concrete ϕV_c can be calculated as follows

$$V_c = \min \left(4, 2 + \frac{4}{\beta_c}, \frac{\alpha_s d}{b_o} + 2 \right) \phi \lambda_s \sqrt{f'_c} b_o d$$

Where;

$$b_o = 4(c + d) = 4(14 + 8.5) = 90''$$

$$\beta_c = \frac{\text{longer side of column}}{\text{shorter side of column}} = \frac{14}{14} = 1$$

$$\alpha_s = 40 \text{ for interior column}$$



Example 5.2

□ Solution

➤ Step 2: Calculation of Punching Shear Capacity

$$\lambda_s = \sqrt{\frac{2}{1 + d/10}} = \sqrt{\frac{2}{1 + 8.5/10}} = 1.04 \leq 1 \rightarrow \text{Take } \lambda_s = 1$$

Now, substituting all these values, we have

$$V_c = \min\left(4, 2 + \frac{4}{1}, \frac{40 \times 8.5}{90} + 2\right) \times 0.75 \times 1 \sqrt{4000} \times 90 \times 8.5$$

$$V_c = \min(4, 6, 5.8) \times 36287.136 = 4 \times 36287.136 = 145148.54 \text{ lb}$$

$$\phi V_c = 145.15 \text{ kip}$$

As

$$\phi V_c = 145.15 \text{ kip} < V_u = 189.16 \text{ kip} \rightarrow \text{Shear design is required}$$



Example 5.2

□ Solution

➤ Step 3: Design for Shear

❖ Option 1: Drop Panels

The thickness of drop panel can be computed by equating V_u with ϕV_c and simplifying the resulting equation for “d” to calculate total depth.

$$h_{tot} = h_s + h_{dp}$$

$$h_{dp} = h_{tot} - h_s$$

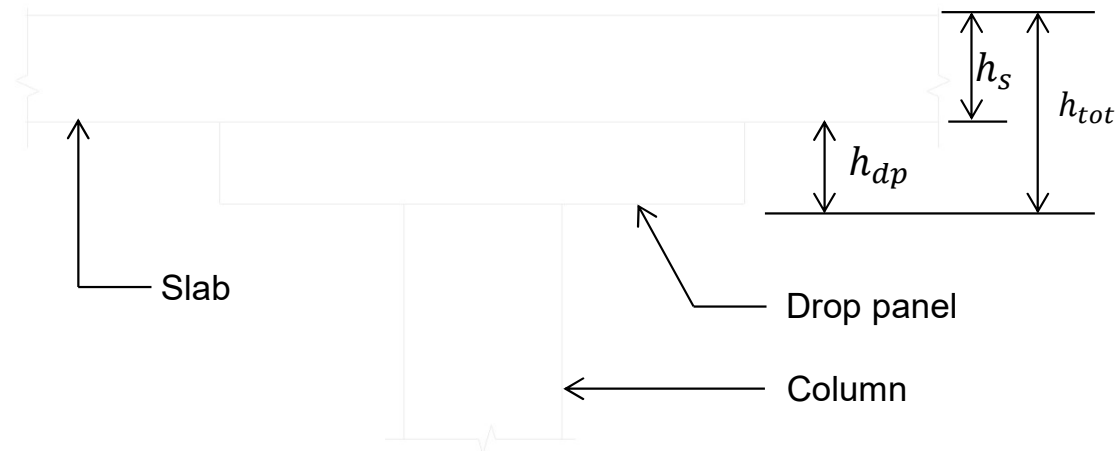



Example 5.2

□ Solution

➤ Step 3: Design for Shear

❖ Option 1: Drop Panels

$$\text{Setting } \phi V_c = V_u \Rightarrow 4\phi\sqrt{f'_c} b_o d = 189.16$$

$$4 \times 0.75 \times \sqrt{4000} \times 90 \times d = 189.16 \times 1000 \Rightarrow d = 11.08''$$

Assuming #6 bar;

$$h_{total} = 11.08 + (0.75 + 6/8) = 12.6''$$

Now, drop panel depth can be determined as

$$h_{dp} = h_{tot} - h_s = 12.6 - 10 = 2.6''$$

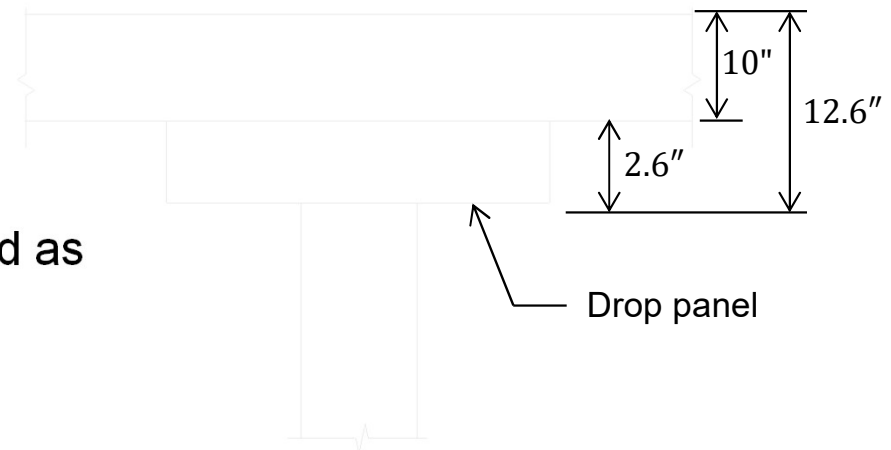



Example 5.2

□ Solution

➤ Step 3: Design for Shear

❖ Option 1: Drop Panels

Minimum thickness of drop panel is given by

$$h_{dp,min} = \frac{h_s}{4} = \frac{10}{4} = 2.5'' \rightarrow \text{calculated depth of } 2.6'' \text{ is OK.}$$

Width of drop panel in each direction is

$$B_1 = l_1/3 + c = 25/3 + 14/12 = 9.5'$$

$$B_2 = l_2/3 + c = 20/3 + 14/12 = 7.83'$$

Hence, provide 2.6" thick 9'- 6" x 7'- 8" drop panels.

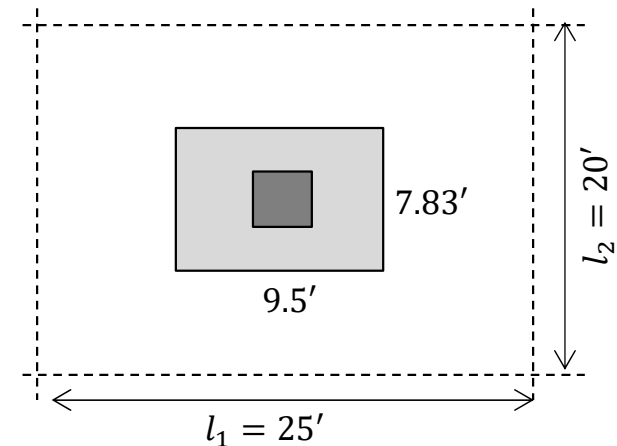



Example 5.2

□ Solution

➤ Step 3: Design for Shear

❖ Option 2: Column Capitals

Setting $\phi V_c = V_u \Rightarrow 4\phi\sqrt{f'_c} b_o d = 189.16$ and calculate b_o

$$4 \times 0.75 \times \sqrt{4000} \times b_o \times 8.5 = 189.16 \times 1000 \Rightarrow b_o = 117.29''$$

As $b_o = 4(c + d) \Rightarrow 117.29 = 4(c + 8.5)$ which gives

$$c = \frac{117.29}{4} - 8.5 = 20.82'' \approx 21''$$

Take width of capital, $D = 21''$



Example 5.2

□ Solution

➤ Step 3: Design for Shear

❖ Option 2: Column Capitals

From figure,

$$\tan\theta = \frac{3.5}{y}$$

According to ACI, $\theta \leq 45^\circ$

$$y = 6.06'' \quad \text{for } \theta = 30^\circ$$

$$y = 9.62'' \quad \text{for } \theta = 20^\circ$$

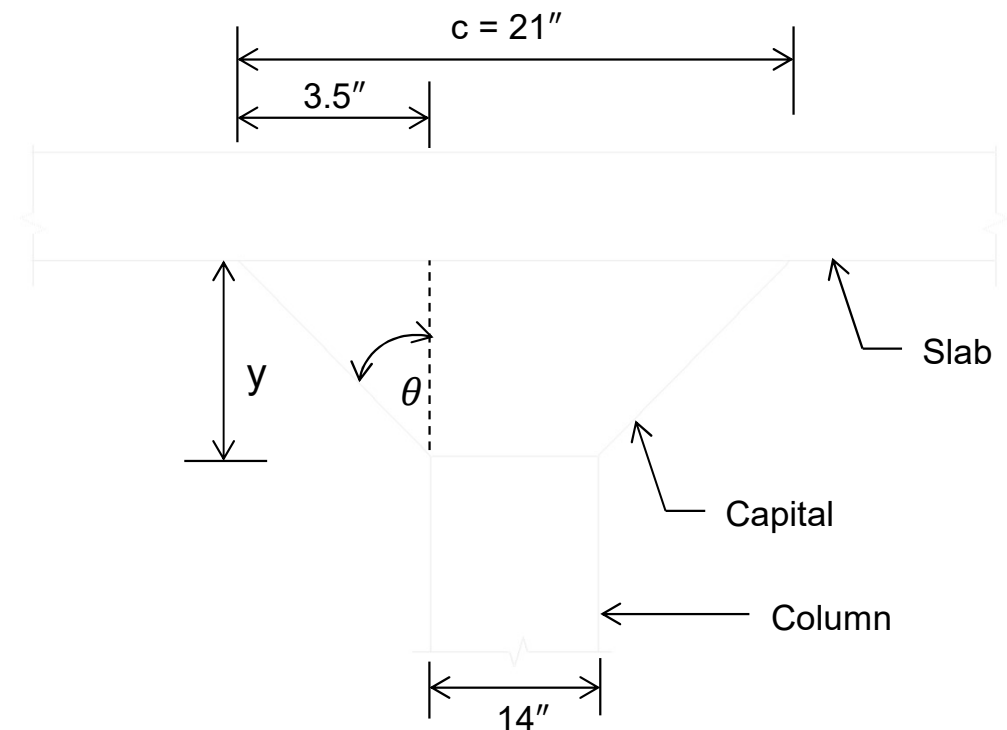



Example 5.2

□ Solution

➤ Step 3: Design for Shear

❖ Option 3: Integral Beams

1. Vertical Stirrups

The required spacing of stirrups can be calculated as

$$s = \frac{\phi A_v f_y d}{V_u - \phi V_c}$$

Using 2-legged #4 bars on all four sides, $A_v = 4(2 \times 0.20) = 1.6 \text{ in}^2$

$$\phi V_c = \frac{145.16}{2} = 72.58 \text{ kip} \quad (\text{Shear capacity of concrete shall be reduced by 2 as per ACI R22.6.6.1})$$



Example 5.2

□ Solution

➤ Step 3: Design for Shear

❖ Option 3: Integral Beams

1. Vertical Stirrups

Substituting the values, we get

$$s = \frac{\phi A_v f_y d}{V_u - \phi V_c} = \frac{0.75 \times 1.6 \times 60 \times 8.5}{189.16 - 72.58} = 5.25''$$

$$s_{max} = \frac{d}{2} = \frac{8.5}{2} = 4.25'' < 5.25'' \rightarrow \text{Not OK}$$

Finally provide #4 @ 4" c/c on all 4 sides.

First stirrup is provided at $s/2 = 2''$ from the face of support.

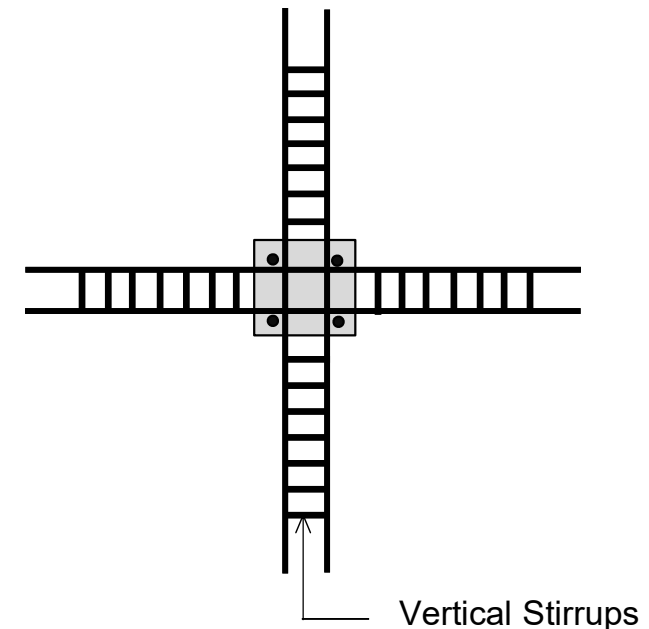



Example 5.2

□ Solution

➤ Step 3: Design for Shear

❖ Option 3: Integral Beams

2. Horizontal Bars

The distance of horizontal bars from center of column to each direction is given by

$$l_v = \frac{b_o - 1.88c}{4.24} = \frac{117.29 - 1.88(14)}{4.24}$$

$$l_v = 21.5'' \approx 24''$$

Hence, provide 2 - #5 bars each measuring 4 feet in length for both directions.

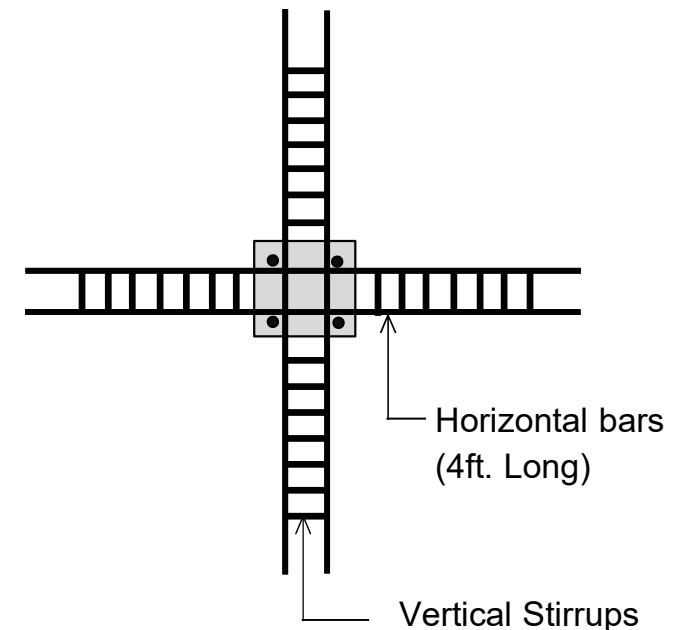



Example 5.2

□ Solution

➤ Step 3: Design for Shear

❖ Option 3: Integral Beams

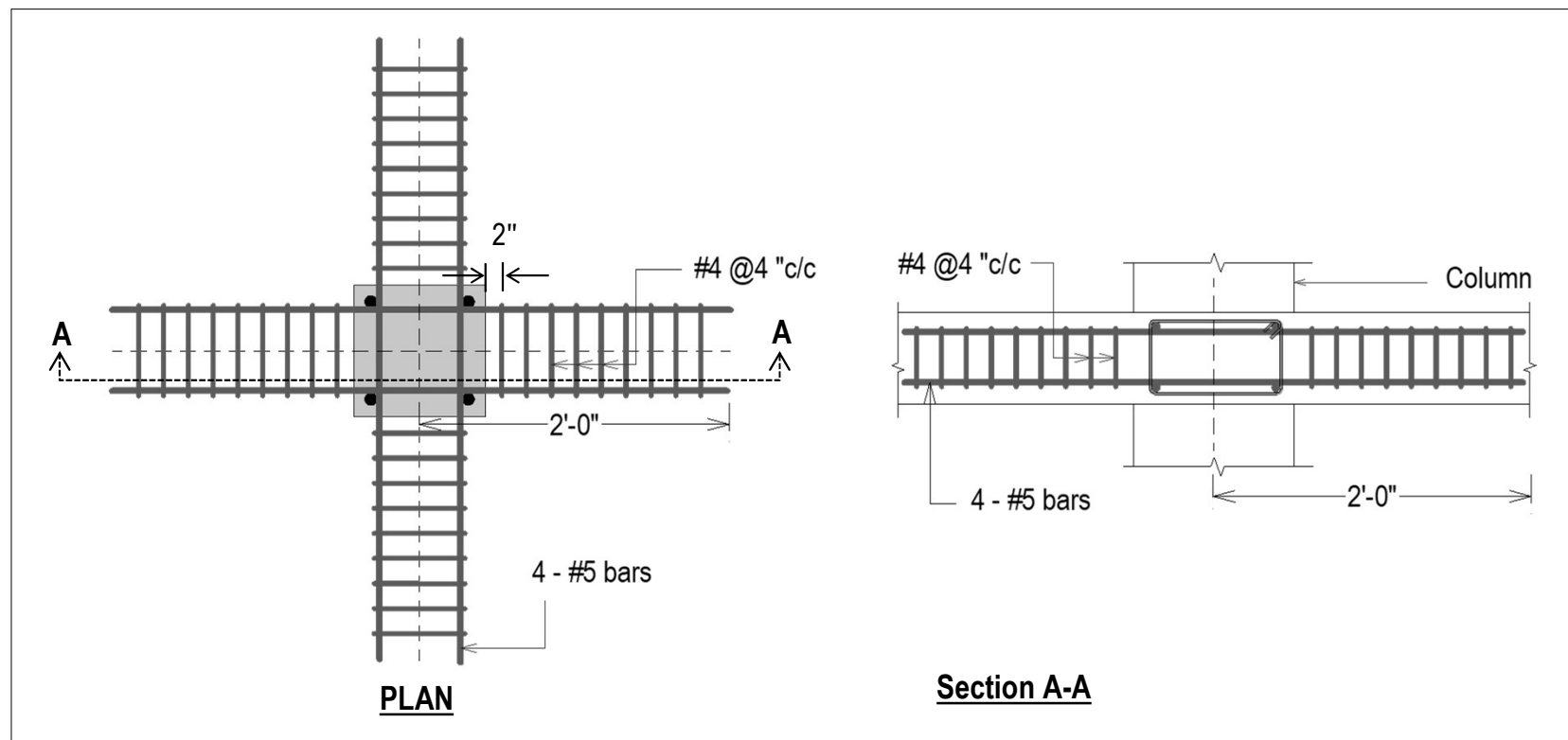



References

- Design of Concrete Structures 14th / 15th edition by Nilson, Darwin and Dolan.
- Building Code Requirements for Structural Concrete (ACI 318-19)

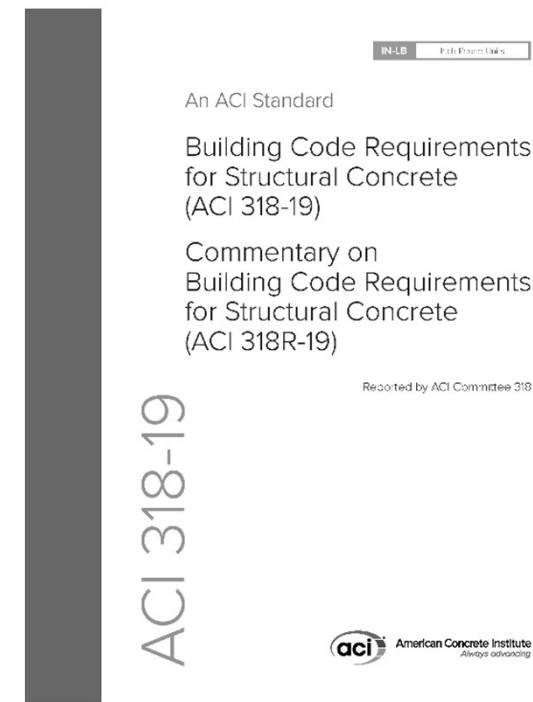
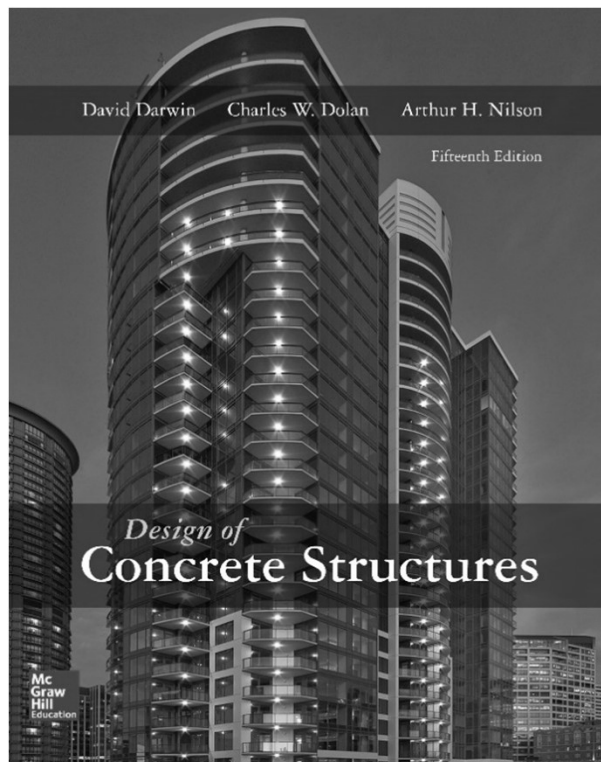



Appendix

□ Combined Distribution of Static Moment

- The combined distribution of Total Static Moment M_o can be expressed as follows.

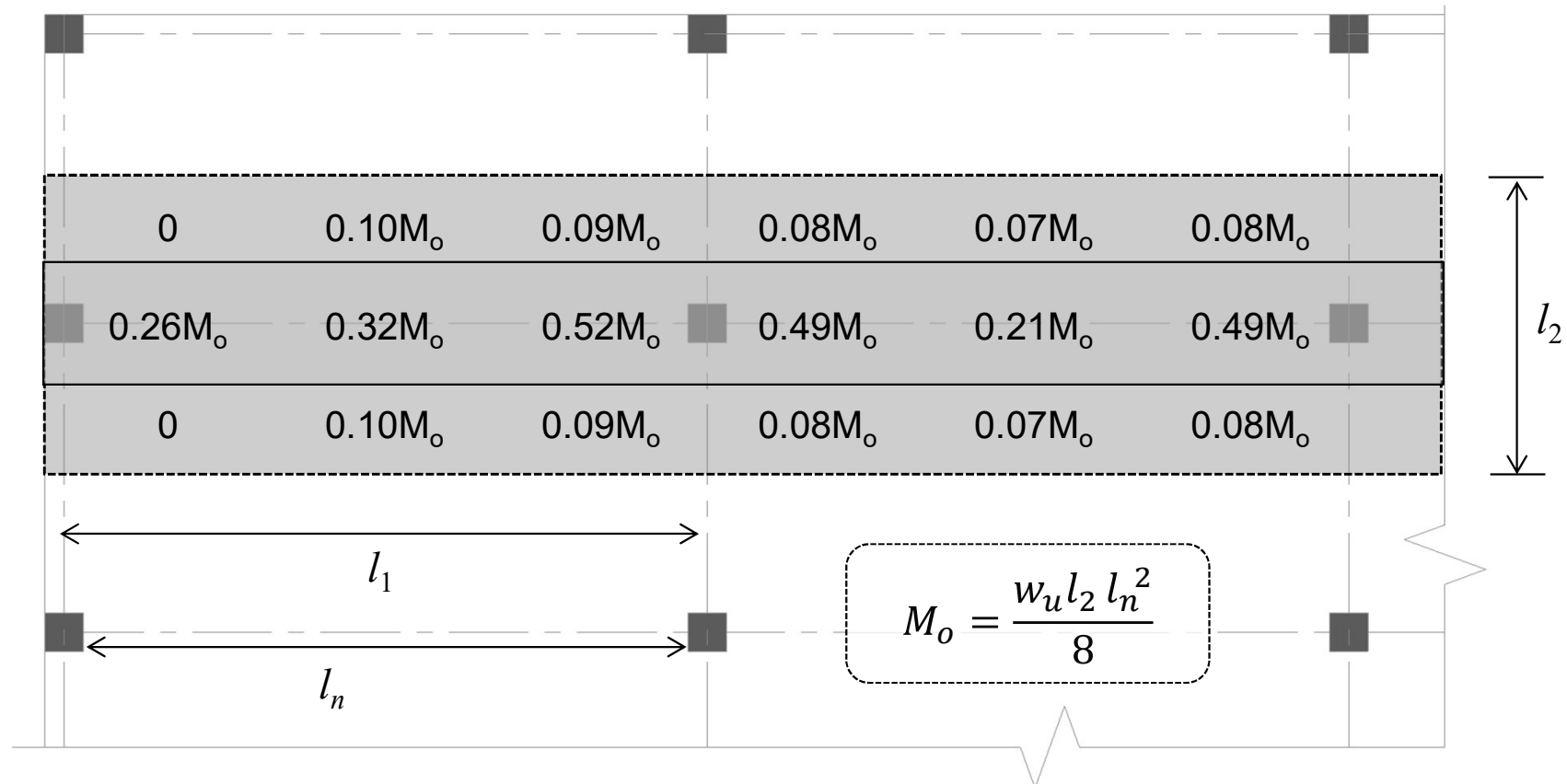



Appendix

□ Combined Distribution of Static Moment

- The combined distribution of Total Static Moment M_o can be expressed as follows.

