



# Lecture 10

## Design of Beam-Column Connections in Monolithic RC Structures

By:

Prof. Dr. Qaisar Ali

Civil Engineering Department

UET Peshawar

[drqaisarali@uetpeshawar.edu.pk](mailto:drqaisarali@uetpeshawar.edu.pk)

<https://drqaisarali.com>



# Lecture Contents

- General
- Design of Type 2 Connections
- ACI 352-02 Provisions for Type 2 Connections
- Example 10.1
- Example 10.2
- Example 10.3
- References



# Learning Outcomes

- ❑ **At the end of this lecture, students will be able to;**
  - ***Understand*** beam-column connections and their types
  - ***Design*** RC Type 2 connections as per ACI 352



# General

## □ Joint and Connection

- A beam-column joint is defined as the **portion of a column within the depth of the deepest beam** that frame into the column.
- A connection is the **joint plus the columns, beams, and slab** adjacent to the joint.

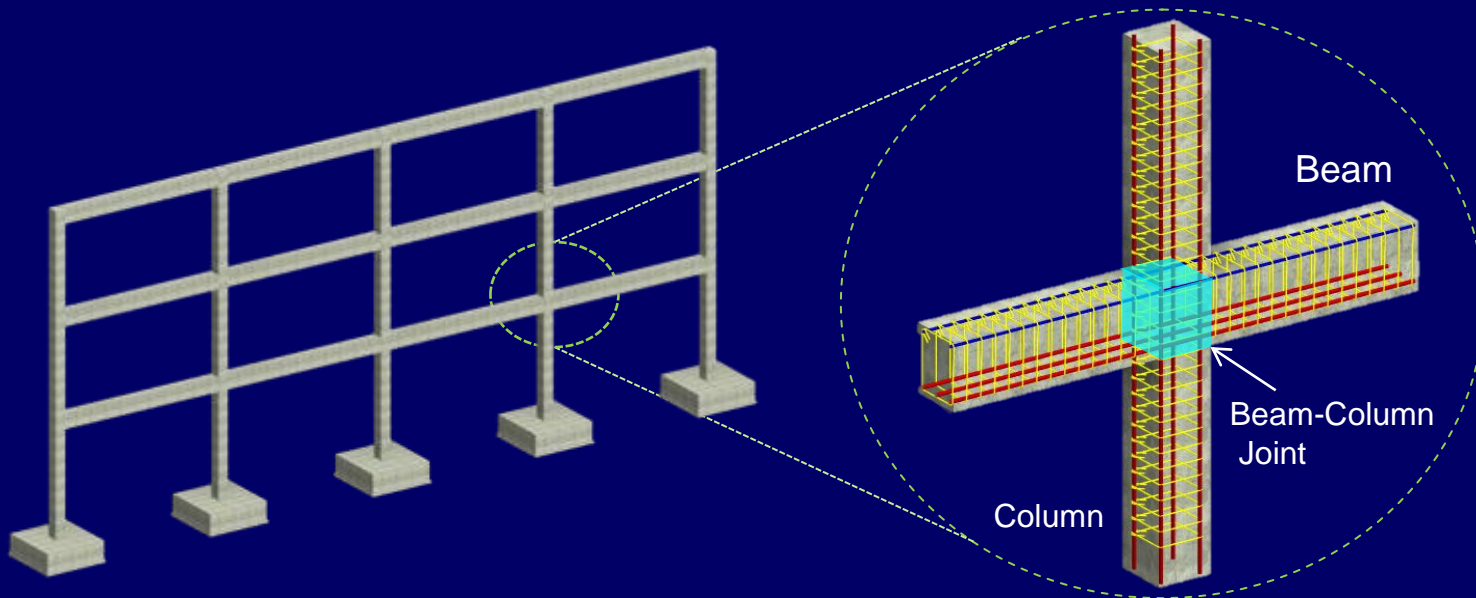



# General

## □ Joint and Connection

- The connection spans from the face of the column to a distance of  $2h$  (where  $h$  is the depth of beam) along the beam, and it also extends into the column up to the distance  $l_o$  as shown below.

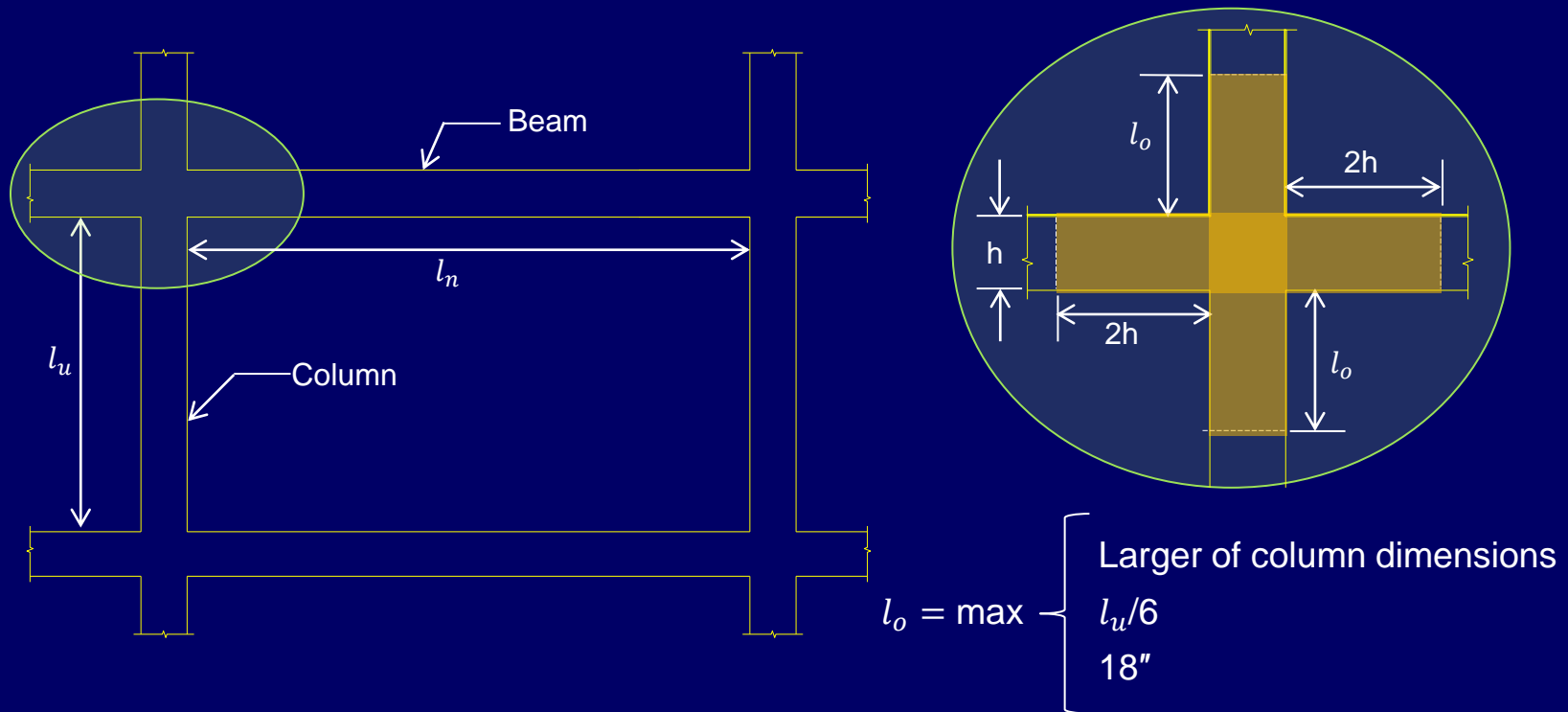



# General

## □ Importance of Joint in Monolithic Structure

- One of the important characteristics of RC structures is their capability of transferring load effects from one member to another through joints. Joints must be rigid and properly designed in order to transfer these actions.
- The structures which exhibit continuity at joints are called monolithic structures.

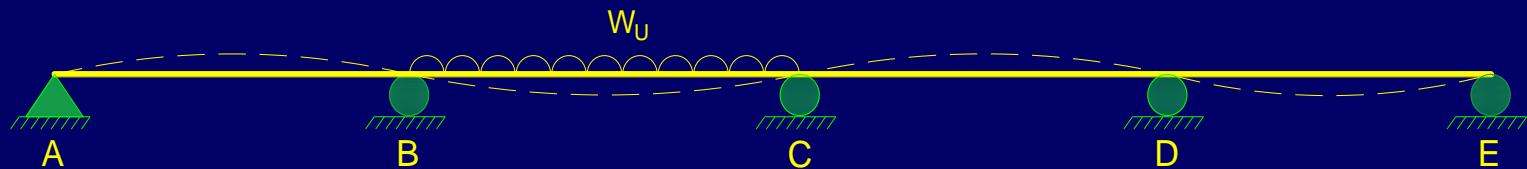



# General

## □ Importance of Joint in Monolithic Structure

- Some frequently used connection details, when tested, have been found to provide as little as 30 percent of the strength required.
- Due to this reason, failure of joints may occur resulting in non monolithic behavior of the structure. Consequently, load transfer from one member to another would not take place in a manner anticipated in monolithic structure.



# General

## □ Connections and the ACI 318-02 code

- ACI 318-19 provides little guidance on design of joints. However, ACI committee-352 gives detailed recommendations for design of joints.
- Therefore ACI 352-02 has been frequently referred in the following sections.





# General

## □ Classification of Beam Column Connections

### ❖ Based on Location

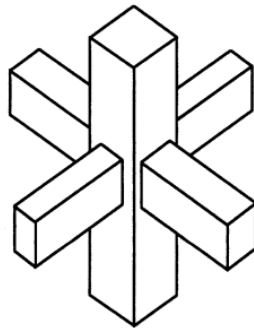

a) Interior

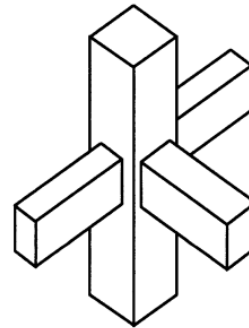

b) Exterior

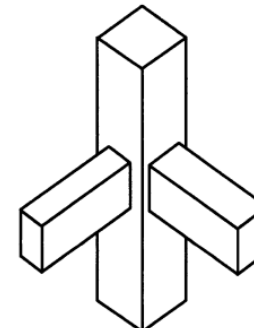

c) Corner

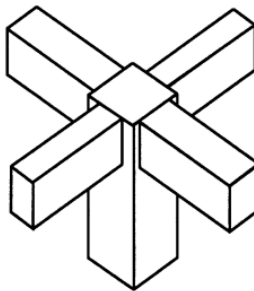

d) "Roof"-interior

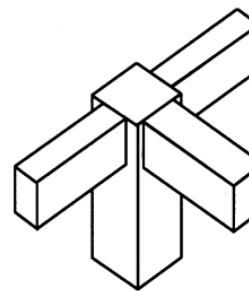

e) "Roof"-exterior

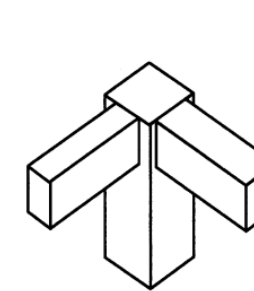

f) "Roof"-corner



# General

## □ Classification of Beam Column Connections

### ❖ Based on Loading Conditions

#### ▪ Type 1 (Gravity Load Resisting Connection)

- Type 1 connection is composed of members designed to satisfy ACI 318-02 strength requirements, excluding Chapter 21, for members without significant inelastic deformation.

#### ▪ Type 2 (Lateral Load Resisting Connection)

- In a Type 2 connection, frame members are designed to have sustained strength under deformation reversals into the inelastic range.



# General

## □ Behavior of Connections

### ❖ Sign Conventions

- To understand behavior of connections easily, the sign convention followed for deflection and bending moment discussed in earlier lectures is recalled.



# General

## □ Behavior of Connections

### ❖ Sign Conventions

#### ▪ Gravity Load Case

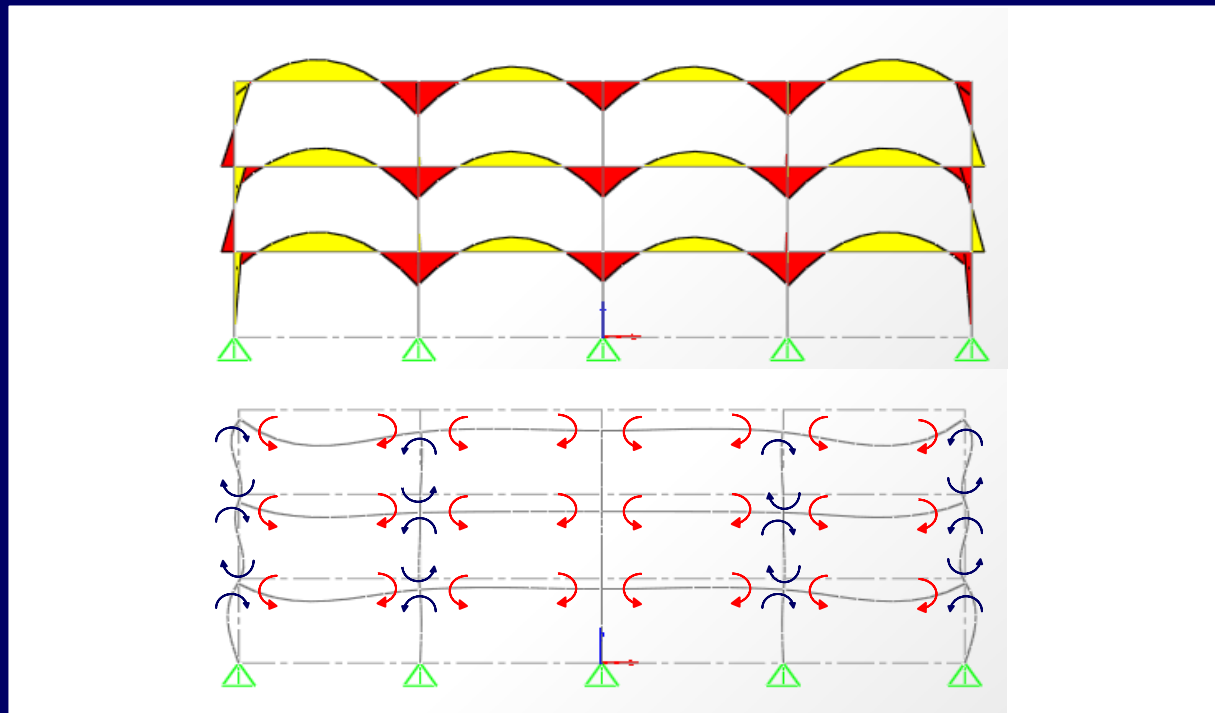



# General

## □ Behavior of Connections

### ❖ Sign Conventions

#### ▪ Lateral Load Case

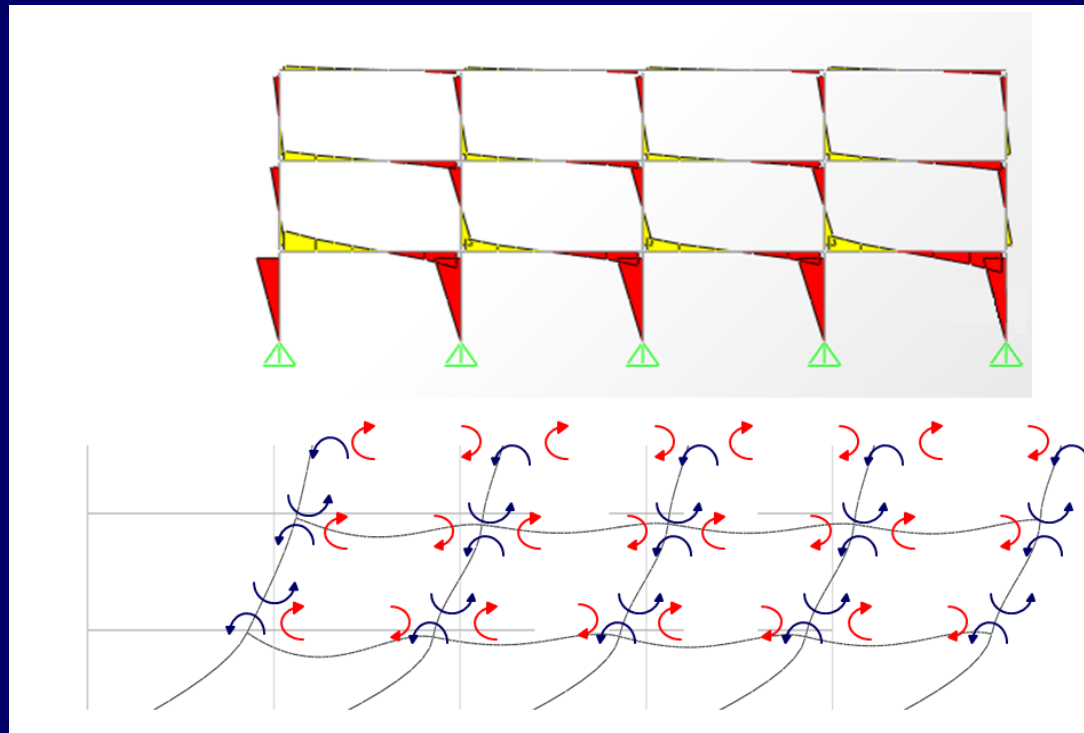



# General

## □ Behavior of Connections

### ❖ Sign Conventions

#### ▪ Comparison of Gravity Load and Lateral Load Cases

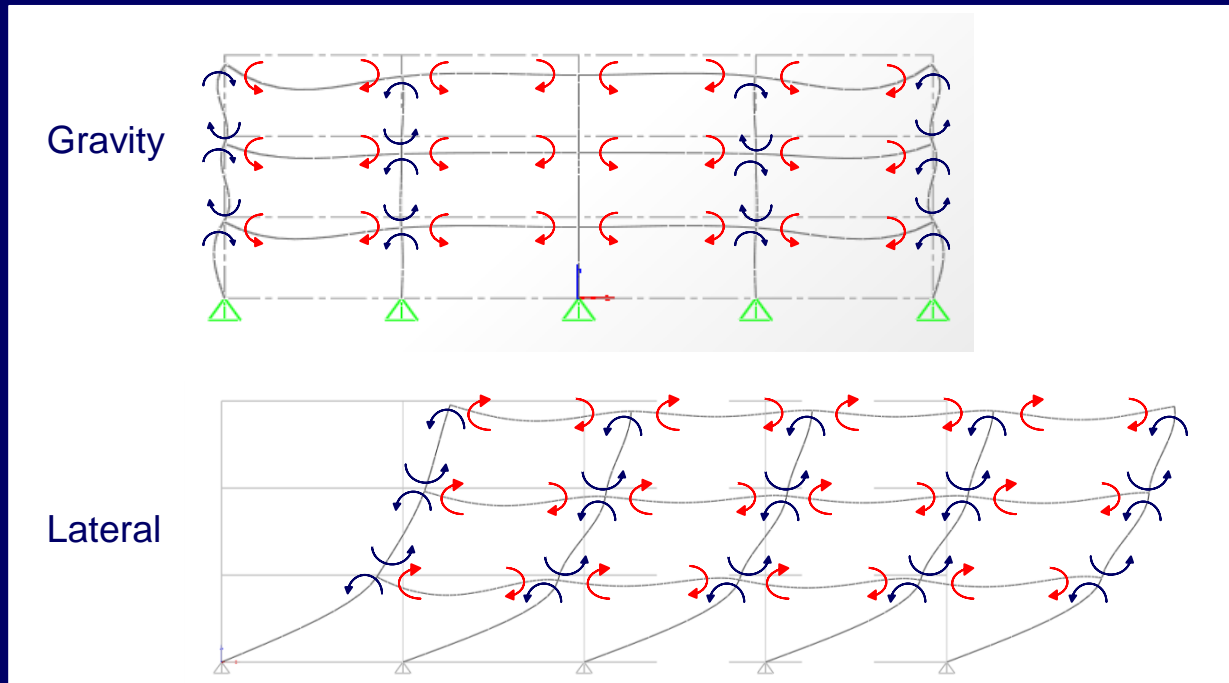



# General

## □ Behavior of Connections

### ❖ Behavior Under Gravity Load

- An RC frame with unequal spans subjected to gravity load is shown below

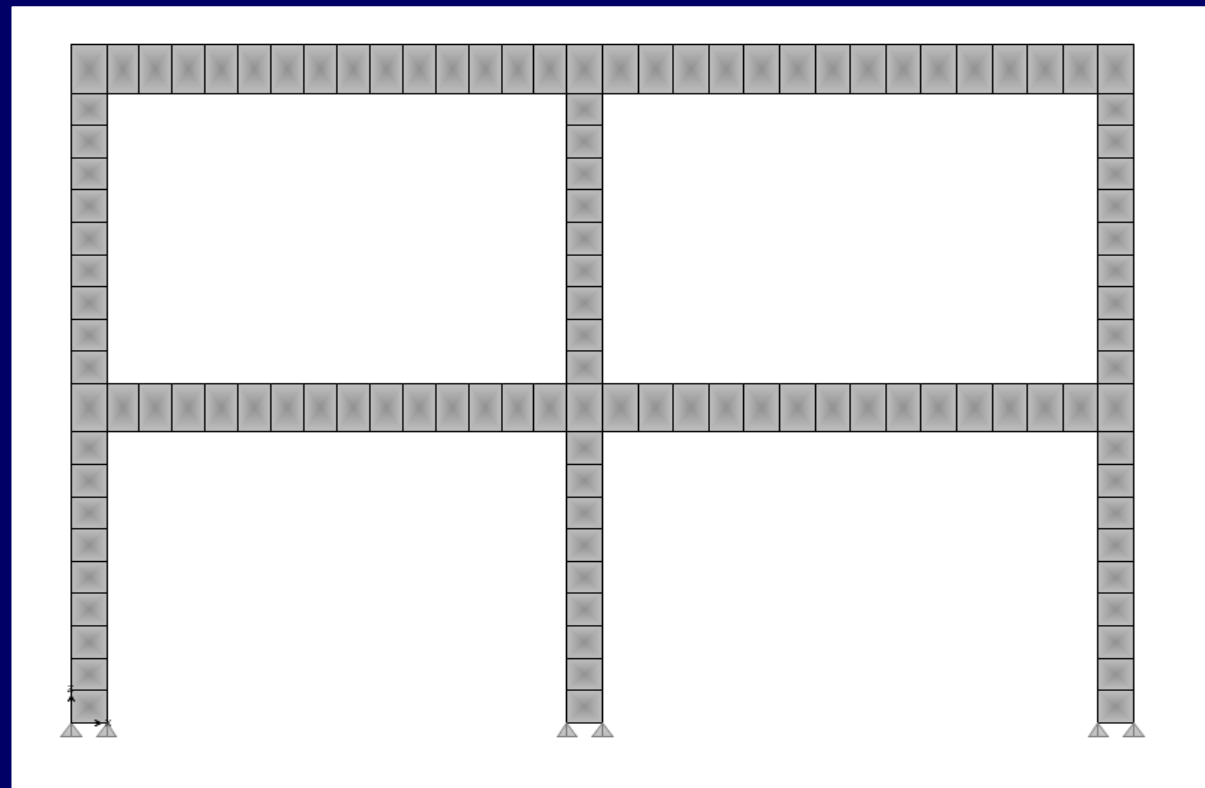



# General

## □ Behavior of Connections

### ❖ Behavior Under Gravity Load

- An RC frame with unequal spans subjected to gravity load is shown below

The joint considered is subjected to flexure, shear, and axial load effects.

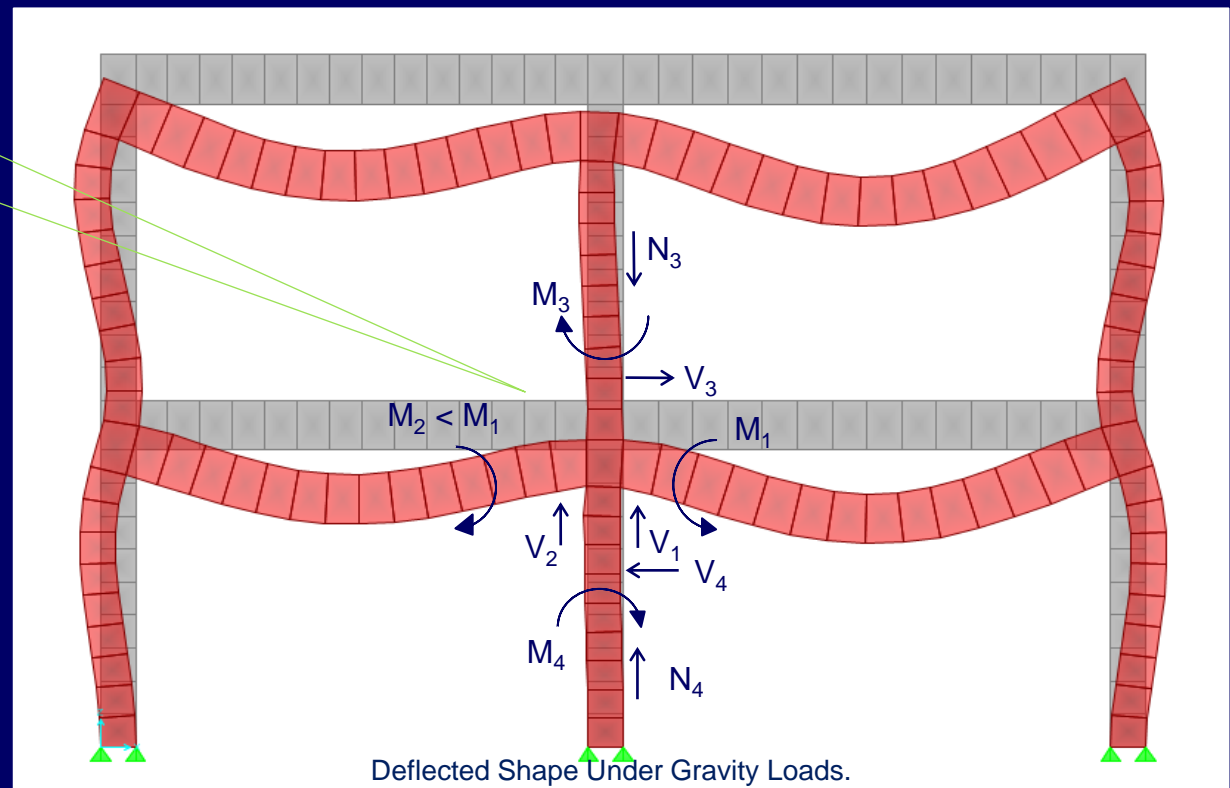





# General

## □ Behavior of Connections

### ❖ Behavior Under Gravity Load

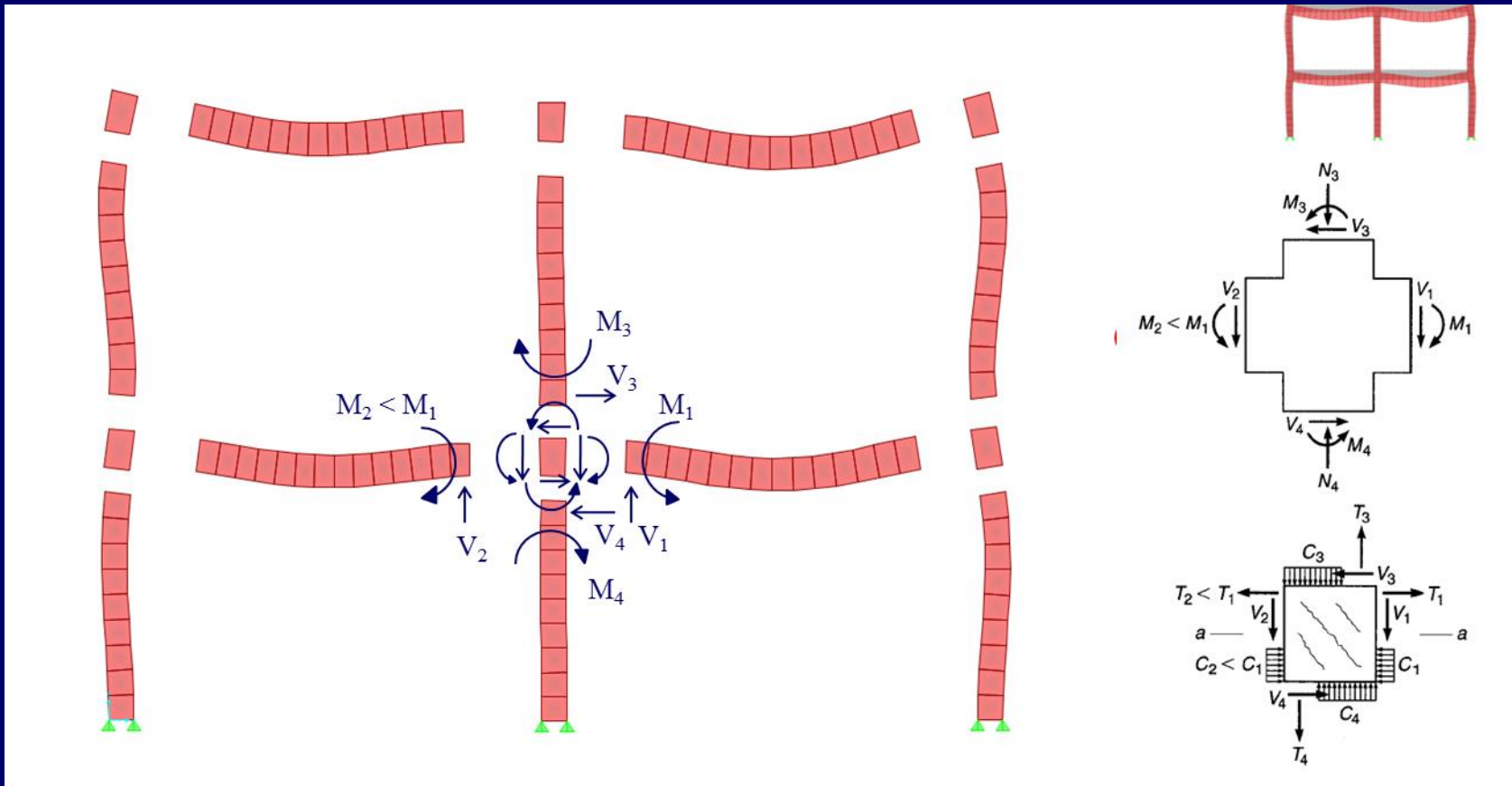



# General

## □ Behavior of Connections

### ❖ Behavior Under Lateral Load

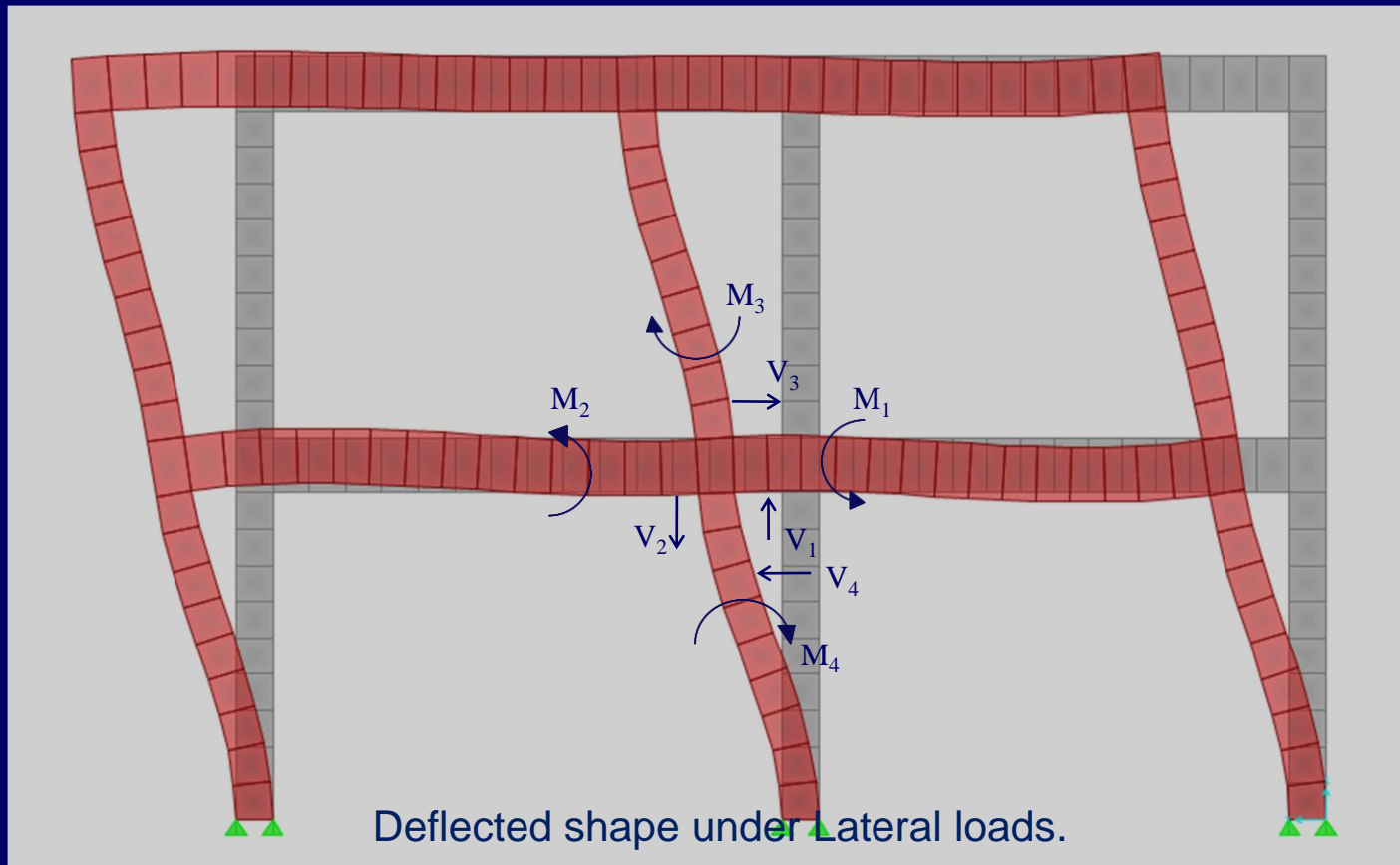



# General

## □ Behavior of Connections

### ❖ Behavior Under Lateral Load

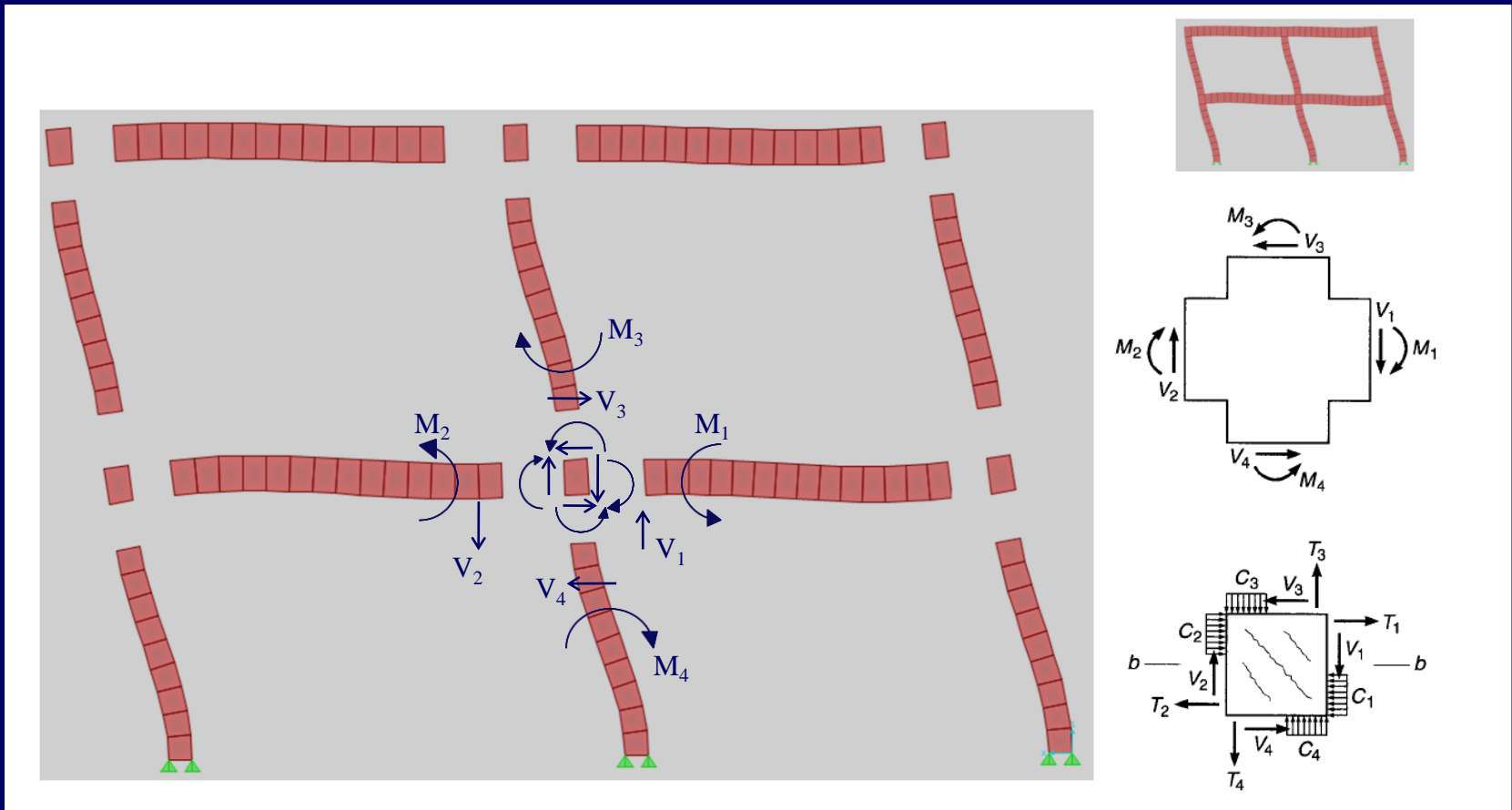



# General

## □ Behavior of Connections

### ❖ Forces acting on a joint with respect to Loading Conditions

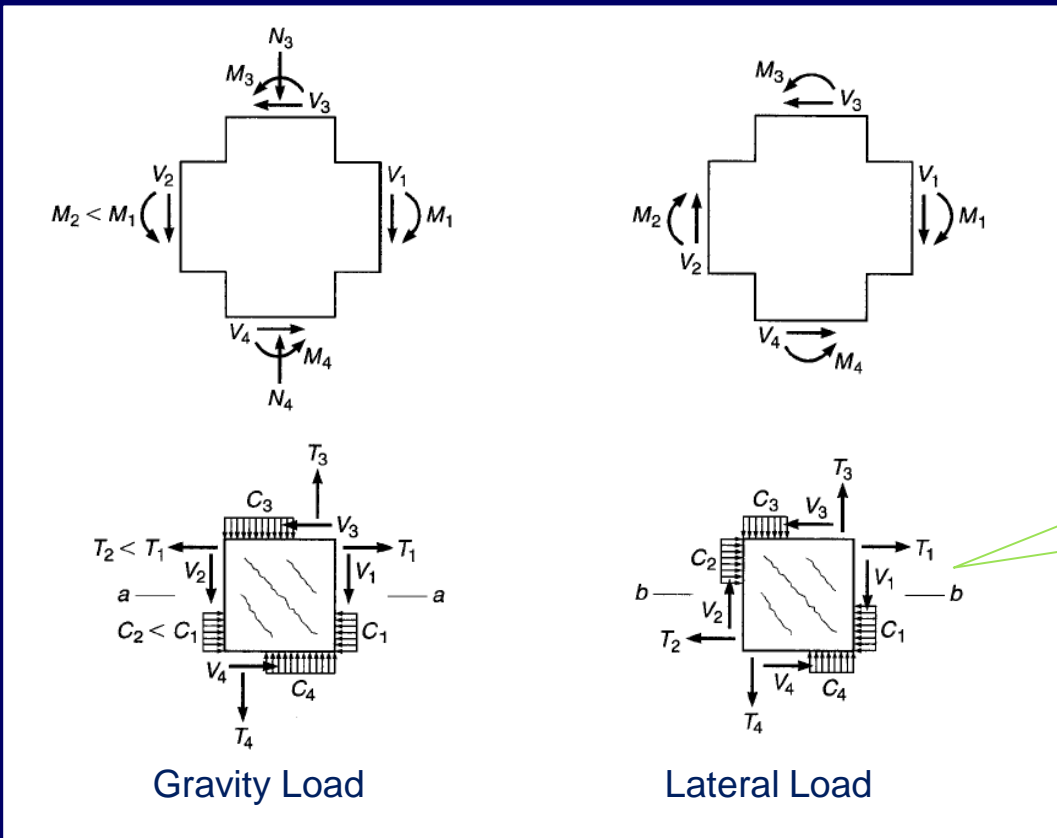

Joint can crack due to action of load effects on it.



# General

## □ Behavior of Connections

### ❖ Forces acting on a joint with respect to Loading Conditions

- If the behavior of joints is examined carefully, it can be observed that the main action causing failure is the horizontal shearing force.
- Shown below, forces  $T_1$ ,  $T_2$ ,  $C_1$ ,  $C_2$ ,  $V_3$  and  $V_4$  are causing shearing of joint along sections a-a and b-b.

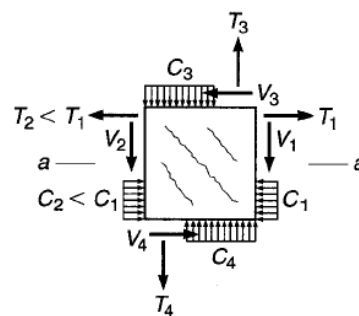

Gravity Load

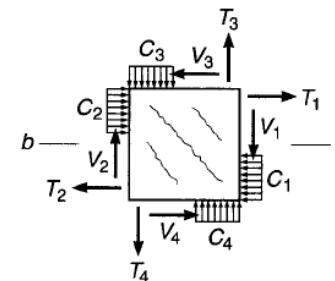

Lateral Load



# General

## □ Behavior of Connections

### ❖ Forces acting on a joint with respect to Loading Conditions

- The horizontal shear is equal to the unbalance horizontal force and can be calculated from the summation of forces above or below a-a/b-b (section at the mid depth), e.g.

$$V_u \text{ (above a-a)} = T_1 - T_2 - V_3 \quad ; \text{and}$$

$$V_u \text{ (above b-b)} = T_1 + C_2 - V_3 \quad ; \text{where } C_2 = T_2$$

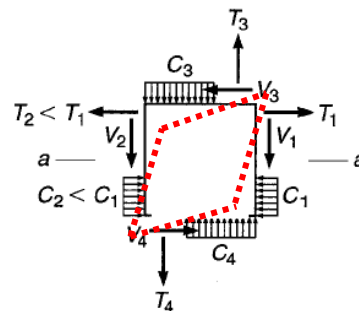

Gravity Load

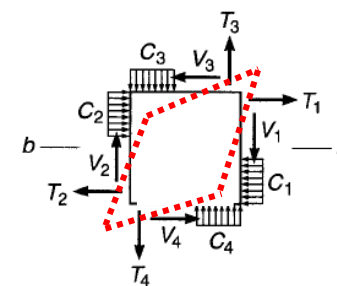

Lateral Load



# General

## □ Type 2 Connections

- As most structures are subjected to earthquake forces, only “Type 2” joints will be discussed in the following slides.
- As discussed earlier, the horizontal shear for type 2 connection is given as:

$$V_u = T_1 + C_2 - V_3 ; \text{ where } C_2 = T_2$$

Where;

- $V_3$  and  $V_4$  are shear forces coming from columns above and below the joint, respectively.

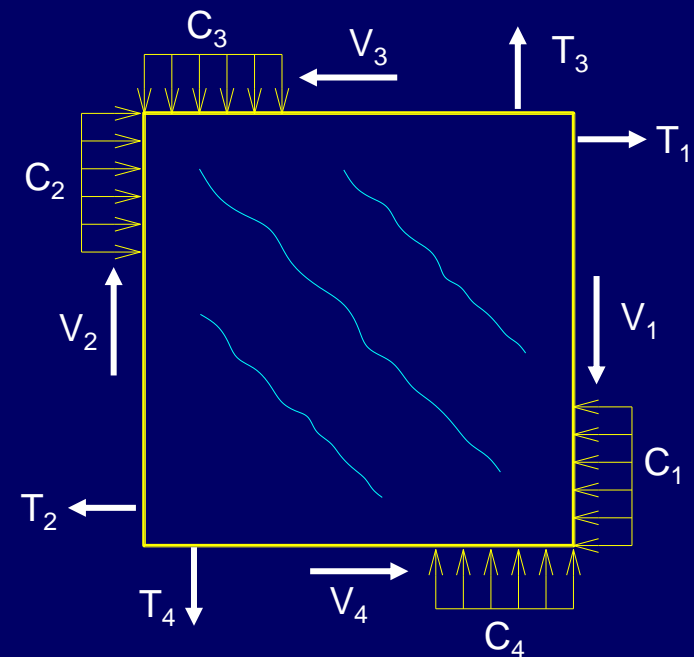



# Design of Type 2 Connections

## □ Forces for Joint Design

- According to ACI 352, the forces ( $T_1$ ,  $T_2$  etc.) to be considered in calculation of  $V_u$  are not those determined from the conventional frame analysis; rather, they are calculated based on the nominal strength of the members i.e., based on the specified dimension and reinforcement.
- Moreover, for member longitudinal reinforcement, the forces should be determined using the stress

$$T_1, T_2 = \alpha A_s f_y$$

Where,  $f_y$  is the specified yield stress of the reinforcing bars and  $\alpha$  is a stress multiplier (ACI 352-02, 3.3.4). For type 2 connections,  $\alpha = 1.25$ .

**NOTE:** The value of  $\alpha = 1.25$  is intended to account for: (a) the actual yield stress of a typical reinforcing bar being commonly 10 to 25% higher than the nominal value; and (b) the reinforcing bars strain hardening at member displacements only slightly larger than the yield rotation.





# Design of Type 2 Connections

## □ Computation of Horizontal Shear

### ❖ Interior Joint

- As per Code requirements, the slab reinforcement shall also be considered in calculation of forces.

$$V_u = T_{b1} + T_{s1} + T_{s2} + C_{b2} - V_{col}$$

As  $C_{b2} = T_{b2}$ , therefore

$$V_u = T_{b1} + T_{s1} + T_{s2} + T_{b2} - V_{col}$$

- $T_{b1}$ ,  $T_{s1}$ ,  $T_{s2}$  and  $T_{b2}$  can be determined based on the nominal dimensions and reinforcement of beam and slab.  $V_{col}$  can be calculated as next.

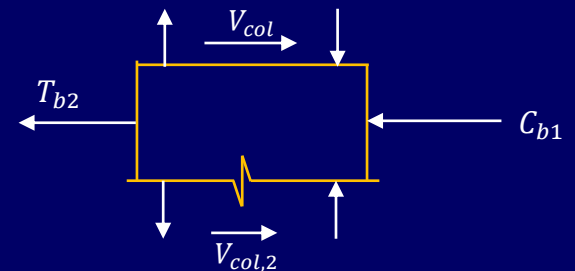
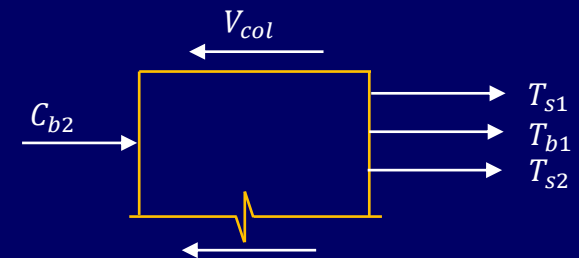

Joint Elevation



# Design of Type 2 Connections

## □ Computation of Horizontal Shear

### ❖ Interior Joint

From figure, the total moment from columns is

$$M_u = M_{c,top} + M_{c,bot} = V_{col} \times \frac{l_c}{2} + V_{col} \times \frac{l_c}{2}$$

$$M_u = V_{col} l_c$$

Also, we have

$$M_u = M_{pr1} + M_{pr2}$$

Therefore,

$$V_{col} l_c = M_{pr1} + M_{pr2}$$

$$V_{col} = \frac{M_{pr1} + M_{pr2}}{l_c}$$

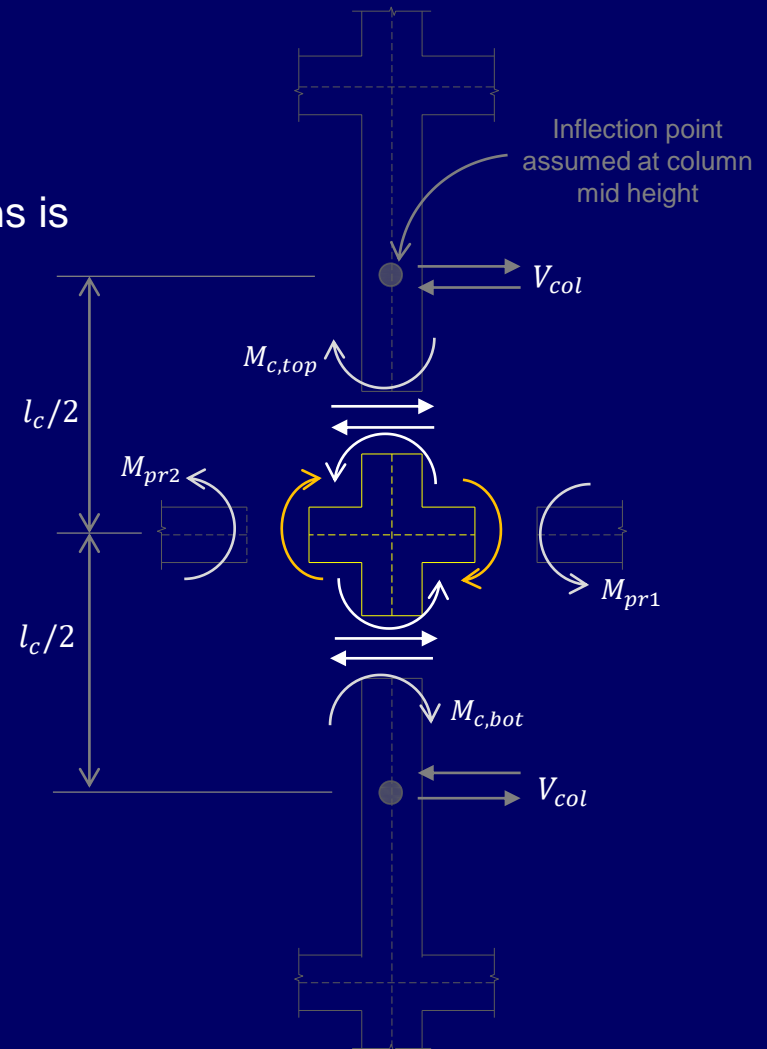



# Design of Type 2 Connections

## □ Computation of Horizontal Shear

### ❖ Interior Joint

From figure, the total moment from columns is

$$M_{c,top} + M_{c,bot} = M_{pr2} + M_{pr2} \text{ ---- Eq (i)}$$

As

$$M_{c,top} = M_{c,bot} = V_{col} \times \frac{l_c}{2}$$

Substituting these values in eq (i), we get

$$V_{col} \frac{l_c}{2} + V_{col} \frac{l_c}{2} = M_{pr1} + M_{pr2}$$

$$V_{col} = \frac{M_{pr1} + M_{pr2}}{l_c}$$

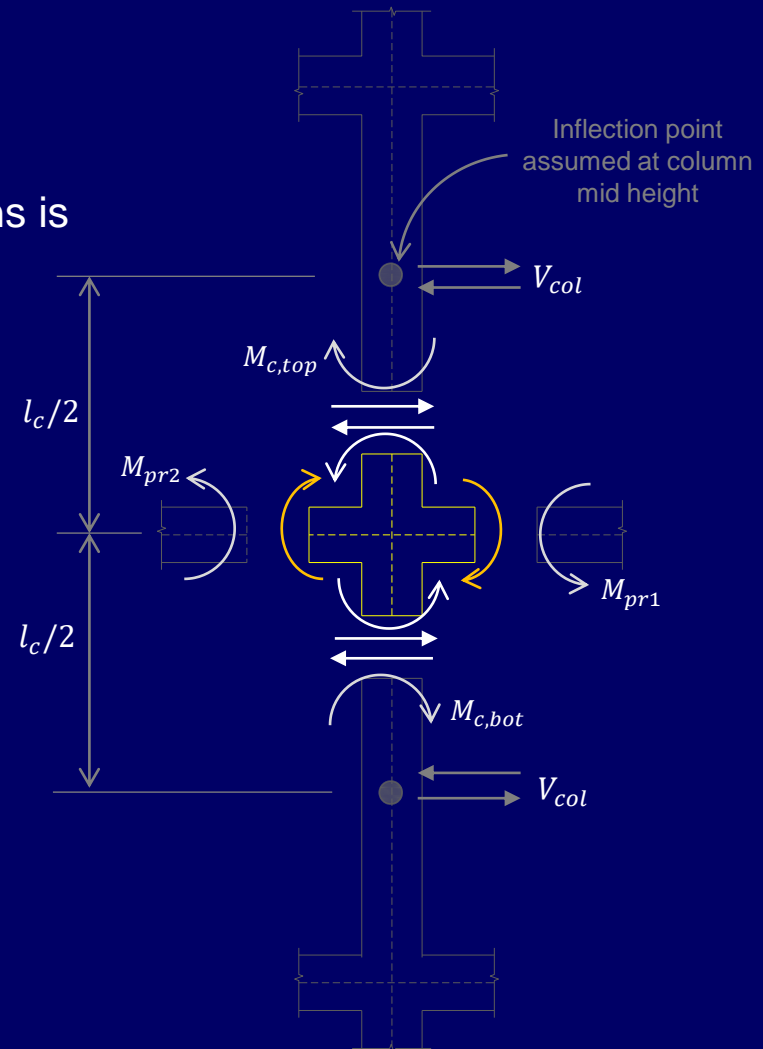



# Design of Type 2 Connections

## □ Computation of Horizontal Shear

### ❖ Interior Joint

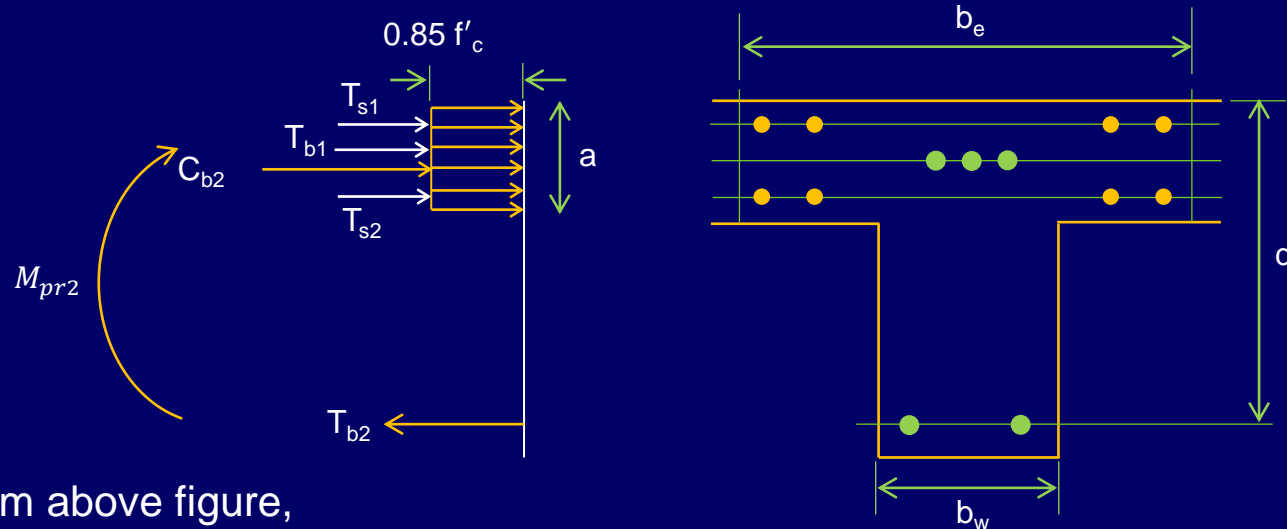

From above figure,

$$M_{pr1} = T_{b2} \left( d - \frac{a}{2} \right)$$

$$C_{b2} = T_{b2} \Rightarrow 0.85 f'_c b_e = T_{b2} \Rightarrow a = \frac{T_{b2}}{0.85 f'_c b_e}$$



# Design of Type 2 Connections

## □ Computation of Horizontal Shear

### ❖ Interior Joint

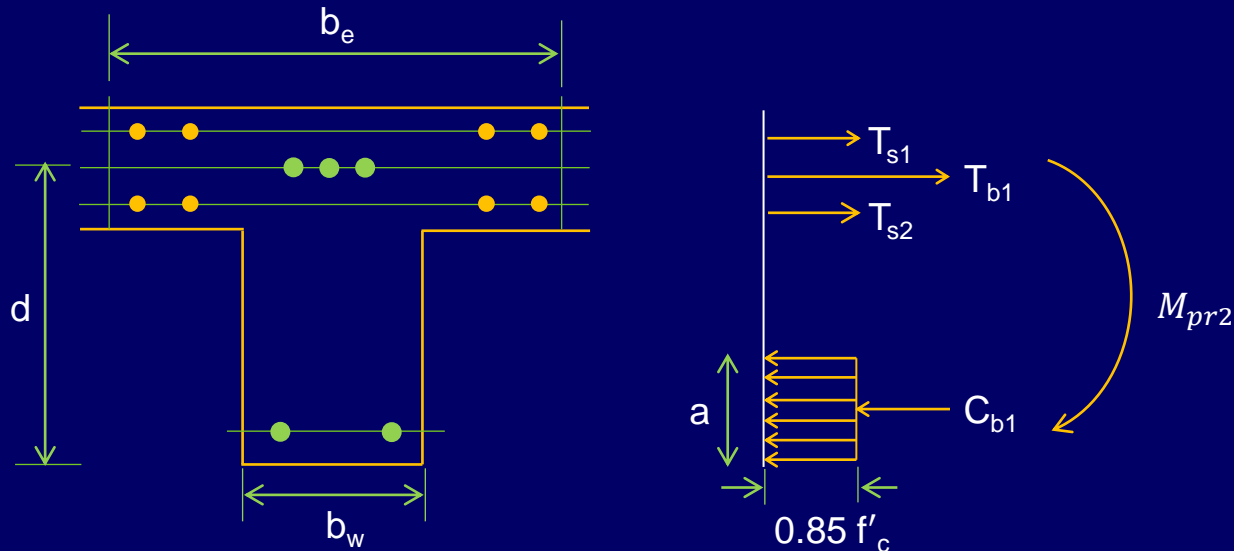

$$M_{pr2} = (T_{b1} + T_{s1} + T_{s2}) \times \left(d - \frac{a}{2}\right)$$

$$C_{b1} = T_{b1} + T_{s1} + T_{s2} \Rightarrow a = \frac{T_{b1} + T_{s1} + T_{s2}}{0.85f'_c b_w}$$



# Design of Type 2 Connections

## Computation of Horizontal Shear

### Interior Joint

So finally, we have

$$V_u = T_{b1} + T_{b2} + T_{s1} + T_{s2} - V_{col}$$

Where;

$$T_{b1} = 1.25A_{s1}f_y \quad ; \quad T_{b2} = 1.25A_{s2}f_y$$

$$T_{s1} = 1.25A_{s,s1}f_y \quad ; \quad T_{s2} = 1.25A_{s,s2}f_y$$

$$V_{col} = \frac{M_{pr1} + M_{pr2}}{l_c}$$

$$M_{pr1} = T_{b2} \left( d - \frac{a}{2} \right) \quad ; \quad a = \frac{T_{b2}}{0.85f'_c b_e}$$

$$M_{pr2} = (T_{b1} + T_{s1} + T_{s2}) \times \left( d - \frac{a}{2} \right) \quad ; \quad a = \frac{T_{b1} + T_{s1} + T_{s2}}{0.85f'_c b_w}$$

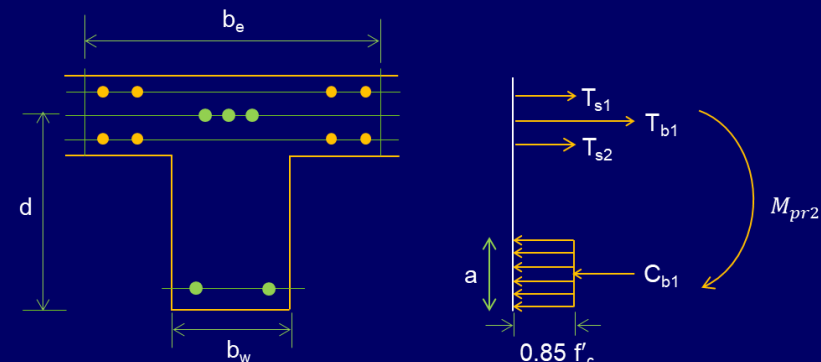
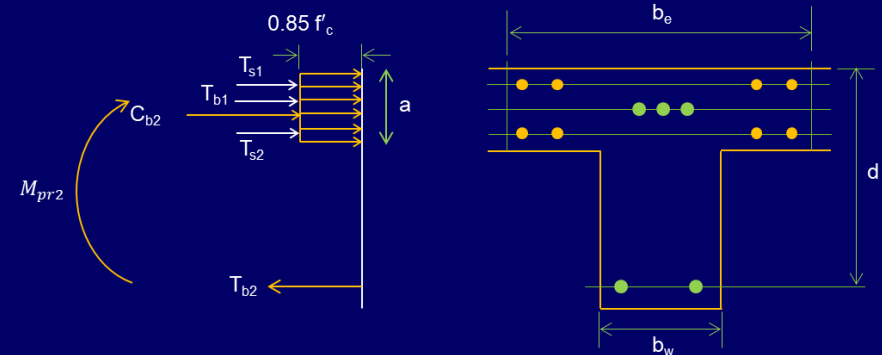



# Design of Type 2 Connections

## □ Computation of Horizontal Shear

### ❖ Exterior Joint

For exterior joints, we have

$$V_u = T_{b1} + T_{s1} + T_{s2} - V_{col}$$

$$M_u = M_{pr2}$$

$$M_{pr2} = (T_{b1} + T_{s1} + T_{s2}) \times \left(d - \frac{a}{2}\right)$$

Where;

$$a = (T_{b1} + T_{s1} + T_{s2}) / 0.85 f'_c b_w$$

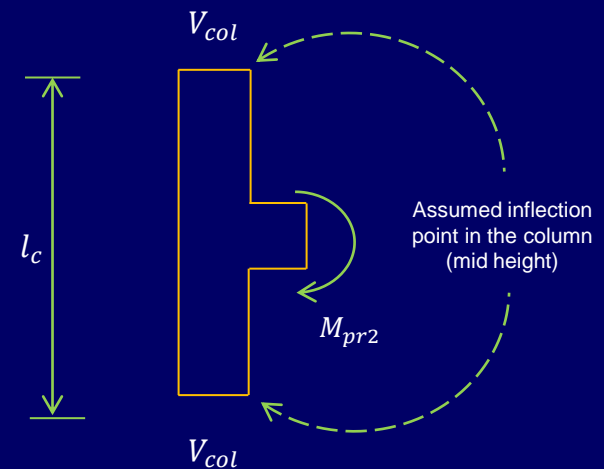
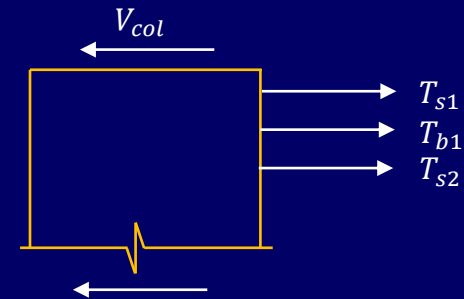



# Shear Capacity of Joint

## □ Nominal Shear Capacity

- The nominal shear capacity of joint  $V_n$  as per ACI 352 R Section 4.3.1 is given by

$$V_n = \gamma \sqrt{f'_c} b_j h_c$$

Where;

- $\gamma$  = constant that depends upon connection classification and type
  - $f'_c$  = concrete compressive strength
  - $b_j$  = the effective width of the joint
  - $h_c$  = the depth of the column in the direction under consideration.
- These parameters are described next.





# Shear Capacity of Joint

## □ Nominal Shear Capacity

### ❖ Determination of $\gamma$

- The term  $\gamma$  can be obtained either from Table 1 or figure 4.5 of ACI 352 report.

Case	Classification	Value of $\gamma$ (for Tye-2 connection)
Joints with continuous column	A1. Joints effectively confined on all vertical faces	20
	A2. Joints effectively confined on three vertical faces or on two opposite vertical faces	15
	A3. Other cases	12
Joints with discontinuous column	B1. Joints effectively confined on all vertical faces	15
	B2. Joints effectively confined on three vertical faces or on two opposite vertical faces	12
	B3. Other cases	8



# Shear Capacity of Joint

## □ Nominal Shear Capacity

### ❖ Determination of $\gamma$

- The term  $\gamma$  can be obtained either from Table 1 or figure 4.5 of ACI 352 report.

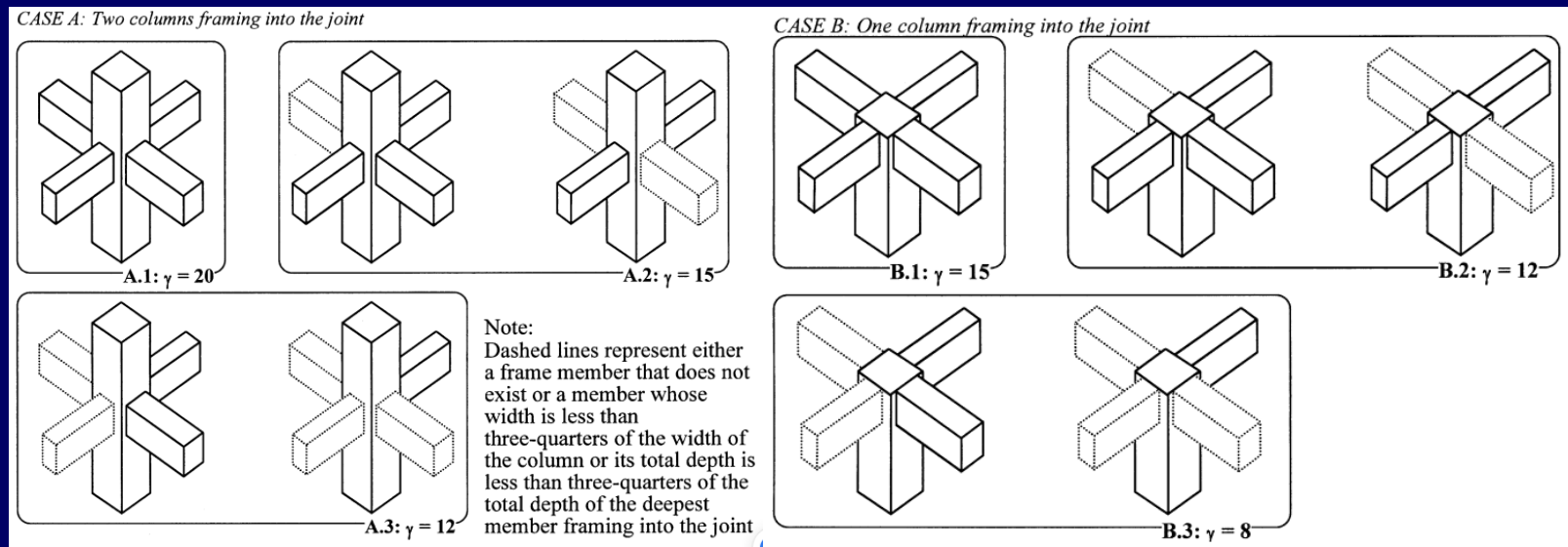



# Shear Capacity of Joint

## □ Nominal Shear Capacity

### ❖ Determination of Effective Width of Joint $b_j$

The effective joint width is given by

$$b_j = \min \left( b_c, \frac{b_b + b_c}{2}, b_b + \frac{\sum mh_c}{2} \right)$$

Where;

$$m = \begin{cases} 0.3 & \text{for } e > b_c/8 \\ 0.5 & \text{else} \end{cases}$$

- The summation term should be applied on each side of the joint where the edge of the column extends beyond the edge of the beam.

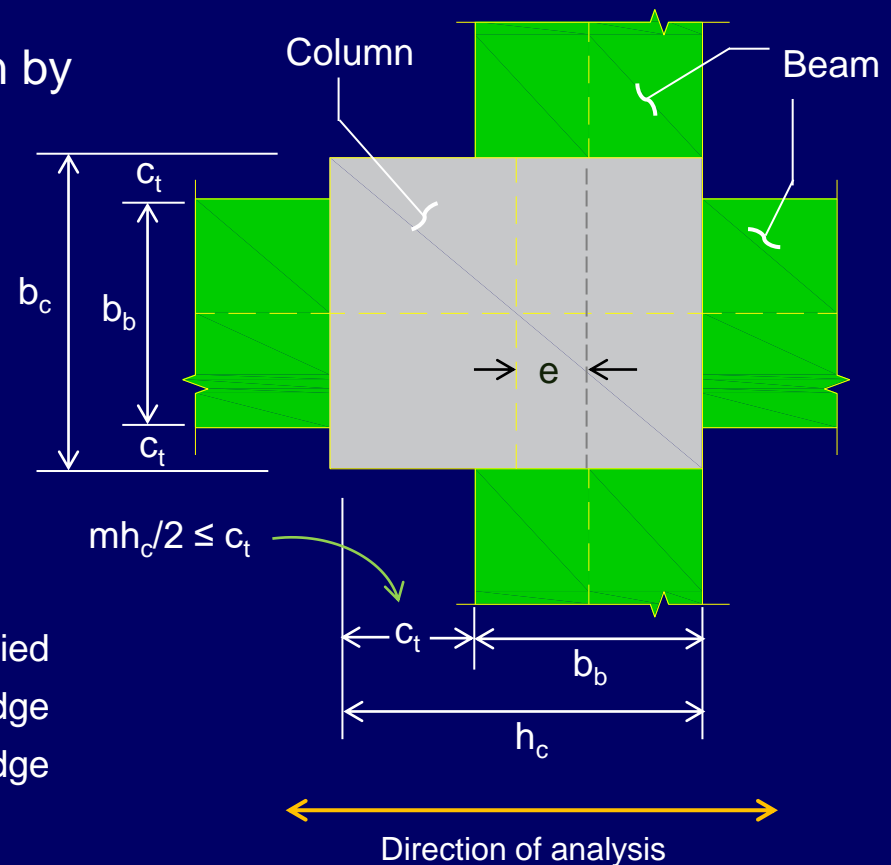



# Shear Capacity of Joint

## □ Design Shear Capacity

- If  $\phi V_n < V_u$ , then increase resisting area of joint, and/or compressive strength of concrete (where  $\phi = 0.75$ ).
- Increasing the area of joint means increasing primarily the dimension of the column.
  - NOTE: Increasing reinforcement in the joint in such a case will not avoid failure of the joint. (ACI R21.5.3)



# ACI 352-02 Provisions for Type 2 Connections

## □ General

- Not only the joint but the beam-column connection as a whole should be designed and detailed such that to enable it to undergo inelastic deformation without failure due to stress reversal resulting from lateral loading.
- Therefore, in addition to the requirement of the code that design shear capacity of a joint  $\phi V_n \geq V_u$ , the ACI-ASCE Joint committee ACI 352 elaborates several other recommendations for Type-2 connections which are discussed in the next slides.





# ACI 352-02 Provisions for Type 2 Connections

## □ Column Longitudinal Reinforcement (4.1)

- Longitudinal bars should be distributed around perimeter of column core.
- The center-to-center spacing between adjacent column longitudinal bars should not exceed minimum of 1/3 of column dimension and 8 in.

$$s_1 = \min\left(\frac{h}{3}, 8''\right)$$

$$s_2 = \min\left(\frac{b}{3}, 8''\right)$$

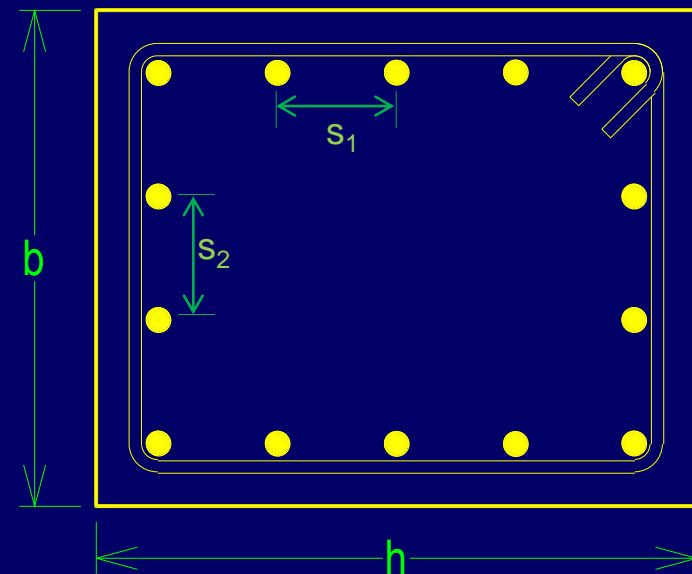



# ACI 352-02 Provisions for Type 2 Connections

## □ Joint Transverse Reinforcement (4.1)

- If a joint is not adequately confined, the total cross-sectional area in each direction of a single hoop, overlapping hoops, or hoops with crossties of the same size in the joint should be at least  $A_{sh}$ .

$$A_{sh} = \text{larger} \left[ 0.3 \frac{s_h b_c'' f_c'}{f_{yt}} \left( \frac{A_g}{A_{ch}} - 1 \right), 0.09 \frac{s_h b_c'' f_c'}{f_{yt}} \right]$$

Where;

- $A_g = bh$
- $A_{ch} = (b - 2c_c)(h - 2c_c)$
- $s_h =$  center-to-center vertical spacing b/w stirrups
- $b_c'' = b - 2c_c$

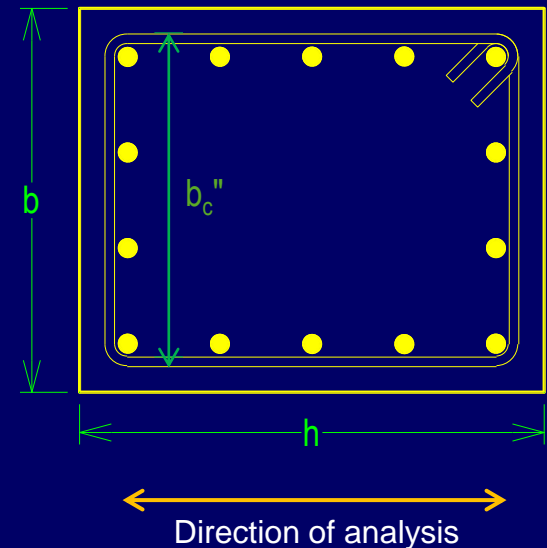

- **NOTE:** If a joint is confined, this reinforcement may be reduced by half.



# ACI 352-02 Provisions for Type 2 Connections

## □ Joint Transverse Reinforcement (4.2)

- The center-to-center spacing between layers of horizontal transverse reinforcement (hoops or hoops and crossties),  $s_h$ , should not exceed  $s_{max}$ .

$$s_{max} = \min \begin{cases} 1/4 \text{ of the minimum column dimension} \\ 6 \times \text{diameter of longitudinal column bars} \\ 6 \text{ inches} \end{cases}$$

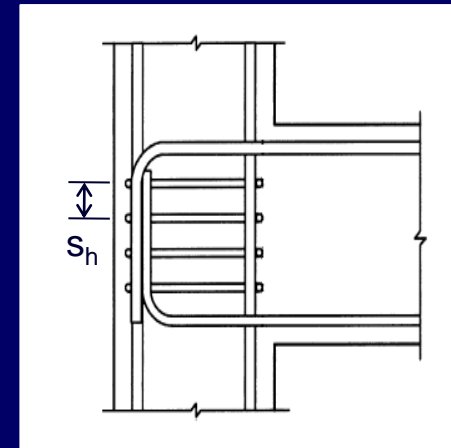

- Spacing limitations apply regardless of confinement conditions.





# ACI 352-02 Provisions for Type 2 Connections

## □ Joint Transverse Reinforcement (4.1)

- ❖ Definition of Adequate Lateral Confining Members for Evaluating Joint transverse Reinforcement

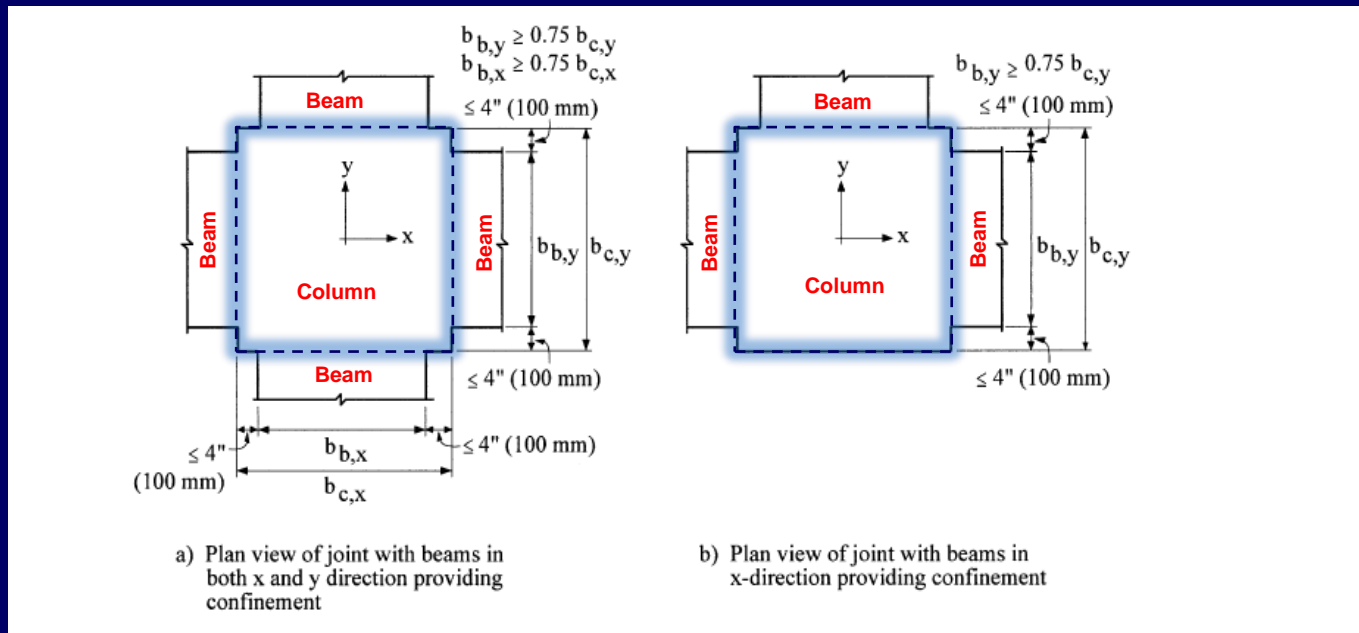



# ACI 352-02 Provisions for Type 2 Connections

## □ Joint Transverse Reinforcement (4.2)

- All hoops should be closed with seismic hooks as defined in Section 25.3 of ACI 318-19.
- Single-leg crossties should be as defined in Section 25.3.5 of ACI 318-19.
- The 90-degree ends of adjacent single-leg crossties should be alternated on opposite faces of the column, except for exterior and corner connections where 135-degree crosstie bends always should be used at the exterior face of the joint.

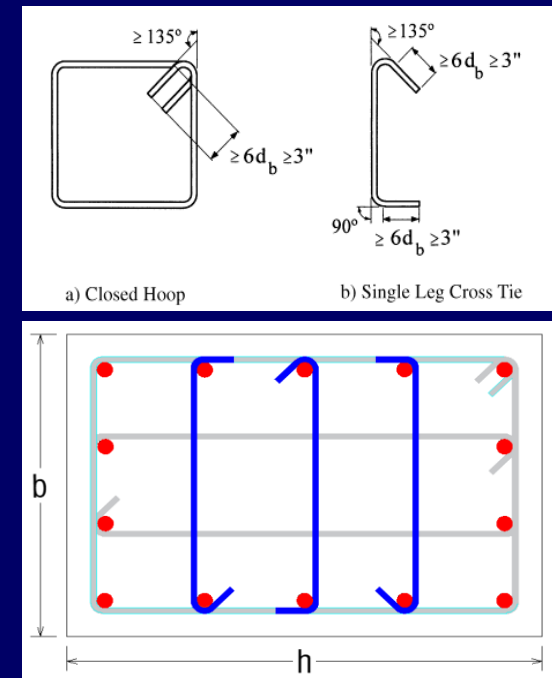



# ACI 352-02 Provisions for Type 2 Connections

## □ Joint Transverse Reinforcement (4.2)

- Crossties, when used, should be provided at each layer of horizontal transverse reinforcement.
- The lateral c/c spacing between crossties or legs of overlapping hoops should not be more than 12 in. and each end of a crosstie should engage a peripheral longitudinal reinforcing bar.

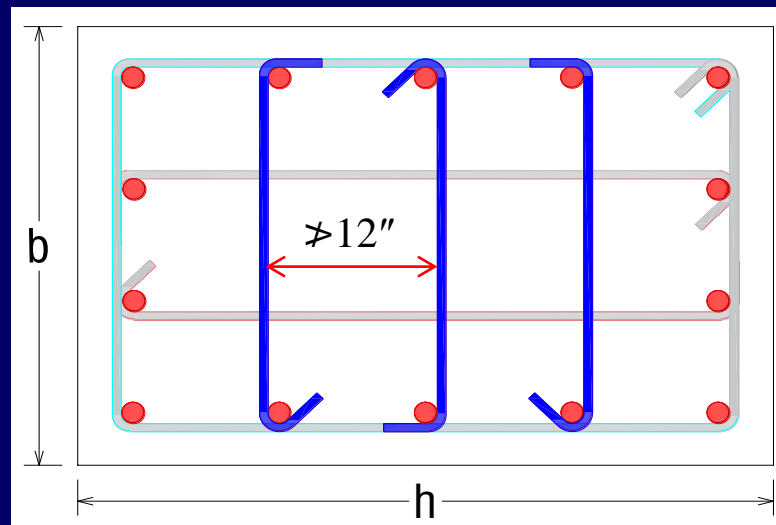



# ACI 352-02 Provisions for Type 2 Connections

## □ Joint Transverse Reinforcement (4.2)

- Where terminating beam bars are the nearest longitudinal reinforcement to the free horizontal face of a joint with a discontinuing column, they should be enclosed within vertical stirrups.
- Each corner and alternate beam bar in the outermost layer should be enclosed in a 90-degree stirrup corner.
- Inverted U-shaped stirrups without 135-degree hooks may be used.

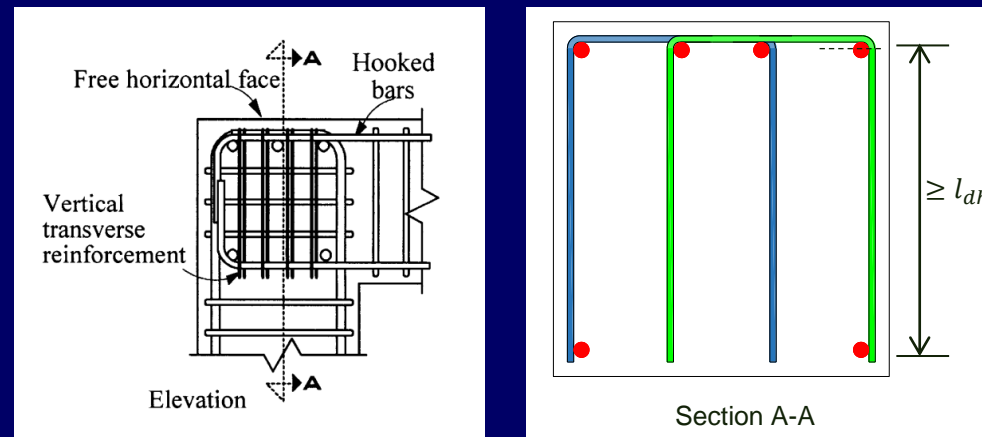



# ACI 352-02 Provisions for Type 2 Connections

## □ Joint Transverse Reinforcement (4.2)

- Horizontal transverse reinforcement  $A_{sh}$  should be placed in the column adjacent to the joint, over the length  $l_o$ .

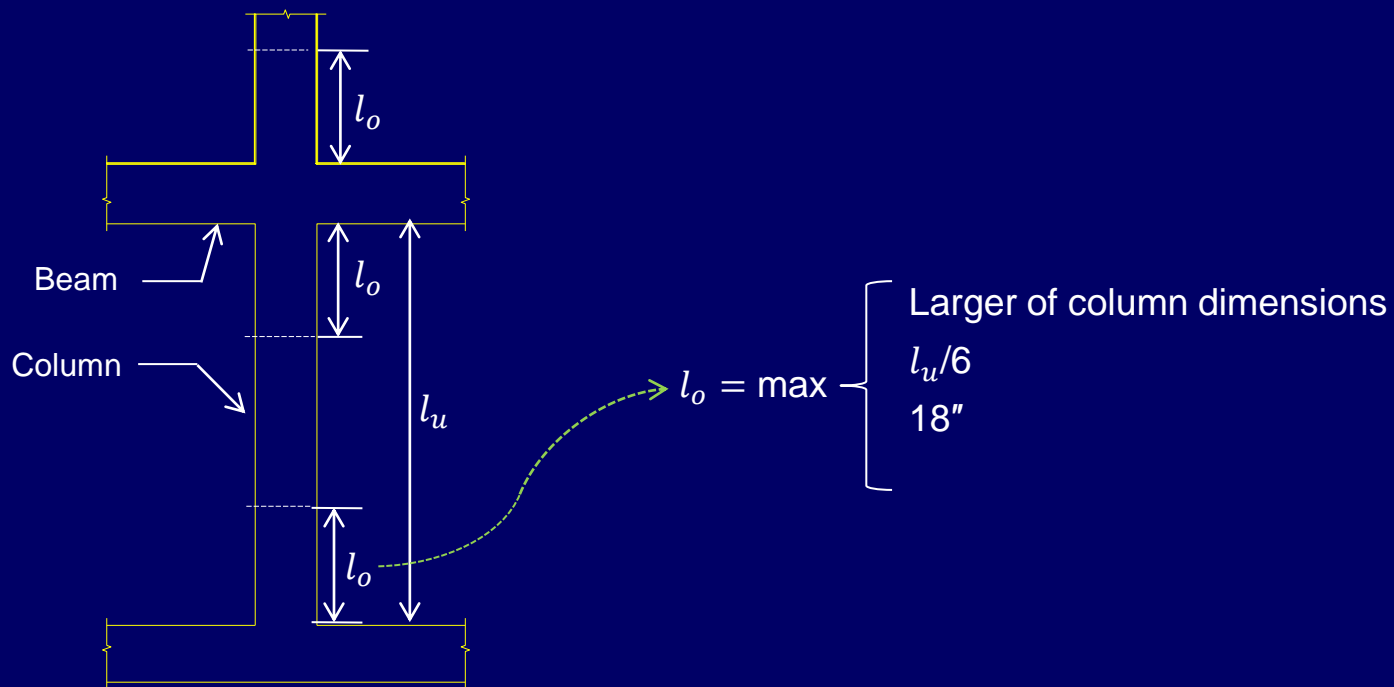



# ACI 352-02 Provisions for Type 2 Connections

## □ Joint Shear (4.3)

- Current provisions require that joint shear strength be evaluated in each direction independently.
- $\phi V_n = \gamma \sqrt{f'_c} b_j h_c \geq V_u$  ; where  $\Phi = 0.75$  as per ACI 21.2 (c).



# ACI 352-02 Provisions for Type 2 Connections

## □ Joint Flexure (4.4)

- At the joint, the following expression must be satisfied:

$$\frac{\sum M_{nc}}{\sum M_{nb}} \geq 1.2$$

Where;

$\sum M_{nc}$  = Sum of nominal flexural strengths of the column sections above and below the joint, calculated using the factored axial load that results in the minimum column-flexural strength.

$\sum M_{nb}$  = Sum of nominal flexural strengths of the beam sections at the joint.

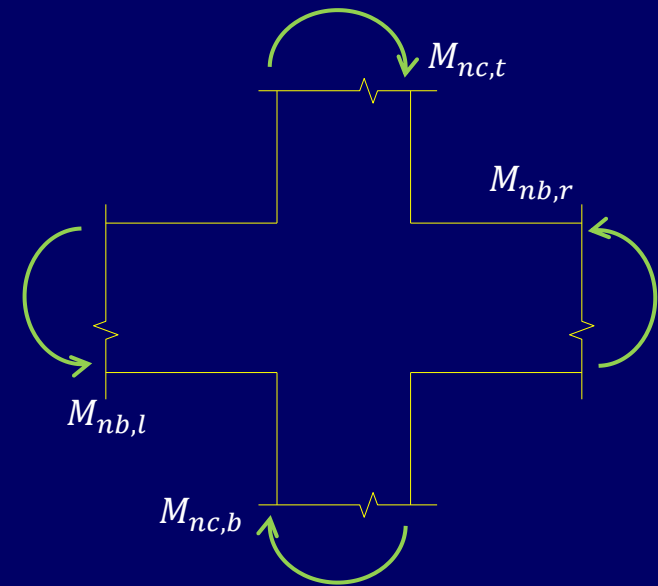

$$M_{nc,t} + M_{nc,b} = 1.2(M_{nb,l} + M_{nb,r})$$



# ACI 352-02 Provisions for Type 2 Connections

## □ Development of Reinforcement (4.5)

- Bars terminating within the confined core of the joint should be anchored using a 90-degree standard hook. The development length, measured from the critical section should be computed as given in the following equation, (Eq 4.10 of ACI 352).

$$l_{dh} = \max \left( \frac{\alpha f_y d_b}{75 \sqrt{f'_c}}, 8d_b, 6'' \right)$$

where  $\alpha = 1.25$  for type 2 connections





# ACI 352-02 Provisions for Type 2 Connections

## □ Development of Reinforcement (4.5)

- Table B.1 shown below is based on anchorage requirements for hooked bars terminating in a joint.

**Table B.1—Minimum column depth for Type 2 connections\***

Bar size, No. (1)	$d_b$ , in. (mm) (2)	$\ell_{dh}$ , in. (mm) (3)	$h$ (min) for column	
			For column hoops at a spacing $> 3d_b$ , in. (mm) (4)	For column hoops at a spacing $\leq 3d_b$ , in. (mm) (5)
6	0.750 (19.0)	11.9 (300)	15.4 (390)	13.0 (330)
7	0.875 (22.2)	13.8 (350)	17.3 (440)	14.6 (370)
8	1.000 (25.4)	15.8 (401)	19.3 (491)	16.1 (411)
9	1.128 (28.6)	17.8 (451)	21.3 (541)	17.8 (451)
10	1.270 (31.8)	20.1 (502)	23.6 (592)	19.6 (491)
11	1.410 (34.9)	22.3 (551)	25.8 (641)	21.3 (530)

\*Based on anchorage of terminating beam longitudinal reinforcement.

Values for  $\ell_{dh}$  have been calculated using  $\alpha = 1.25$ ,  $f_y = 60$  ksi and  $f'_c = 4000$  psi. An extra 3-1/2 in. has been added to  $\ell_{dh}$  to determine the minimum column dimension to anchor a given bar.



# ACI 352-02 Provisions for Type 2 Connections

## □ Development of Reinforcement (4.5)

### ❖ Critical Sections

- For development of longitudinal member reinforcement in columns, the critical section should be taken as the **outside edge of the beam longitudinal reinforcement** that passes into the joint.

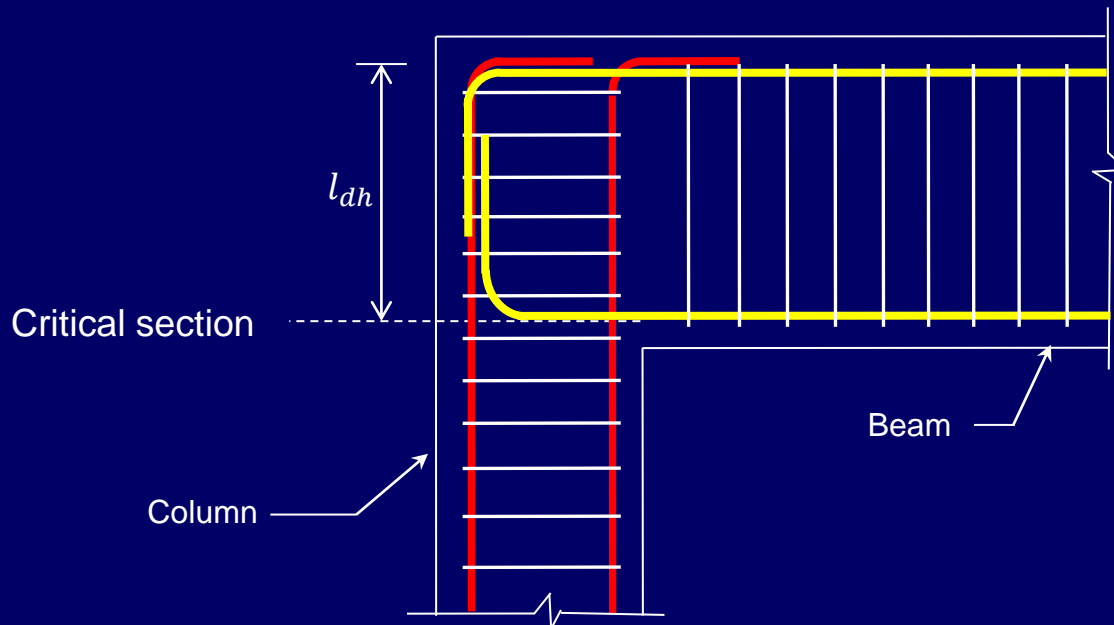



# ACI 352-02 Provisions for Type 2 Connections

## □ Development of Reinforcement (4.5)

### ❖ Critical Sections

- For beam reinforcement, critical section shall be taken at the **outside edge of the column core** (outside edge of transverse reinforcement).

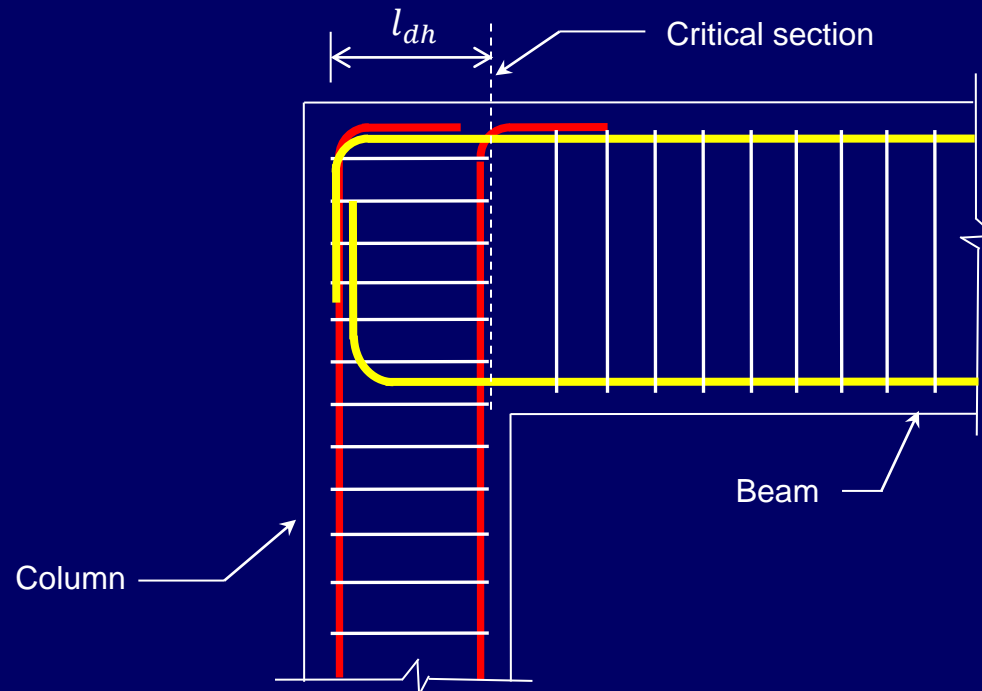



# ACI 352-02 Provisions for Type 2 Connections

## □ Development of Reinforcement (4.5)

### ❖ Location of Hooks

- Hooks should be located within 2 inches of the extent of the confined core furthest from the critical section for development.
- For beams with more than one layer of flexural reinforcement, the tails of subsequent layers of reinforcement should be located within  $3d_b$  of the adjacent tail.

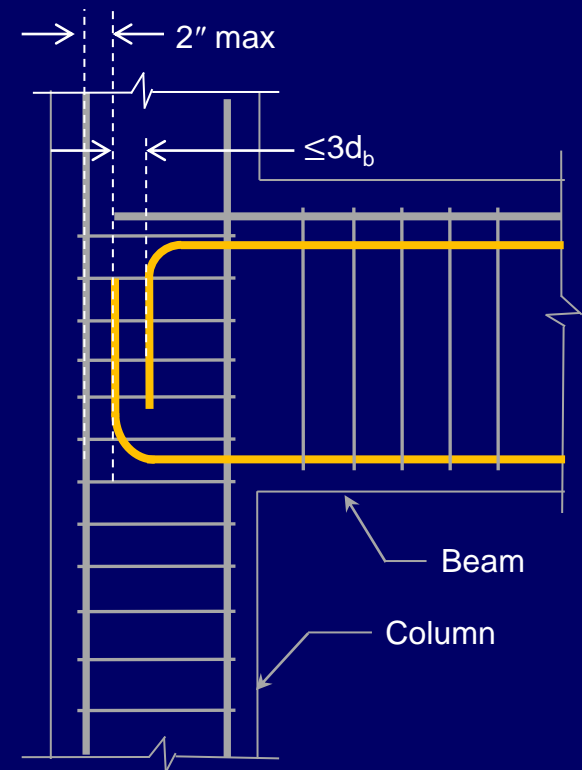



# ACI 352-02 Provisions for Type 2 Connections

## □ Development of Reinforcement (4.5)

### ❖ Beam and Column Bars

- All straight beam and column bars passing through the joint should be selected such that:

$$h_{col} \geq \frac{20f_y}{60000} d_{b,beam}$$

And

$$h_{beam} \geq \frac{20f_y}{60000} d_{b,col}$$

**Table B.2- Minimum column or beam depth for Type 2 Connection (for grade 60 steel)**

Bar Designation	Bar Diameter (in.)	$h_{min}$ (in.)
#6	0.75	15.0
#7	0.875	17.5
#8	1.000	20.0
#9	1.128	22.6
#10	1.270	25.4
#11	1.410	28.2
#14	1.693	33.9



# ACI 352-02 Provisions for Type 2 Connections

## □ Beam Transverse Reinforcement

- Transverse reinforcement as required by chapter 21 of ACI 318-02 should be provided in the beams adjacent to the joint.

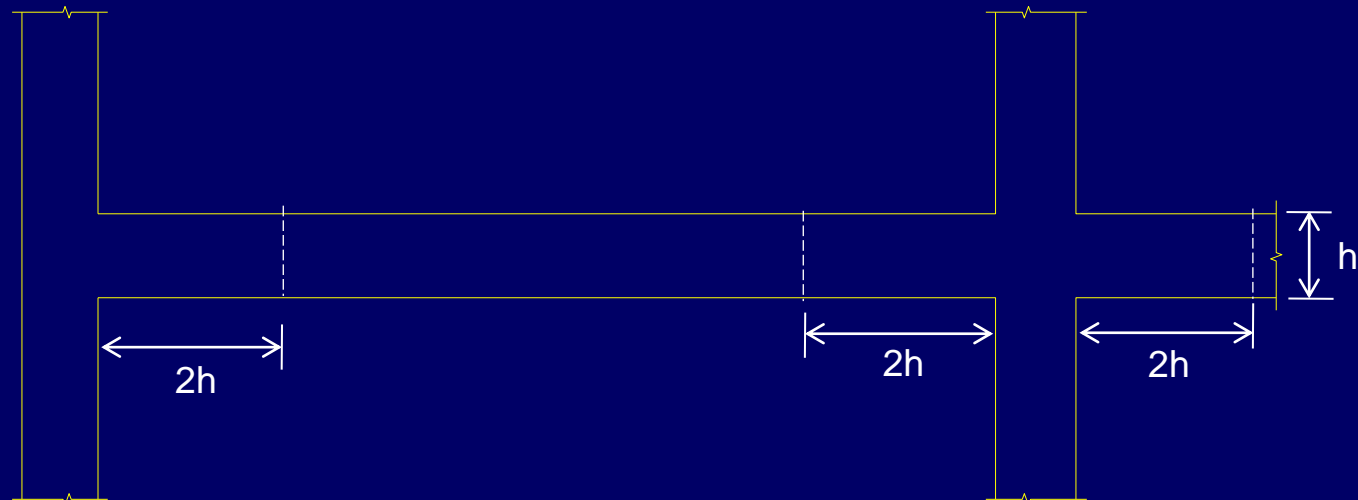



# ACI 352-02 Provisions for Type 2 Connections

## □ Wide Beam Connections

- The requirements for wide beam connections i.e. where beams are wider than the column are separately specified at various sections of ACI 352-02 .
- For the purpose of simplicity and avoiding confusion, such requirements are not included in this presentation. Therefore the reader should himself use the relevant portions of ACI 352-02 for the detailing of such connections.



# Example 10.1

## □ Problem Statement

**Design** the Interior Type 2 connection shown below for N-S direction only.

- Column: 20"x20" with 8-#11 bars, subjected to  $P_u = 400$  kips
- Transverse beam (N-S): 16"x22" with 5 - #8 bars (top) and 3 - #8 (bot)
- Longitudinal beam (E-W): 16"x22" with 5 - #8 bars (top) and 3 - #8 (bot)
- Story height: 12 ft.
- $f'_c = 10$  ksi and  $f_y = 60$  ksi

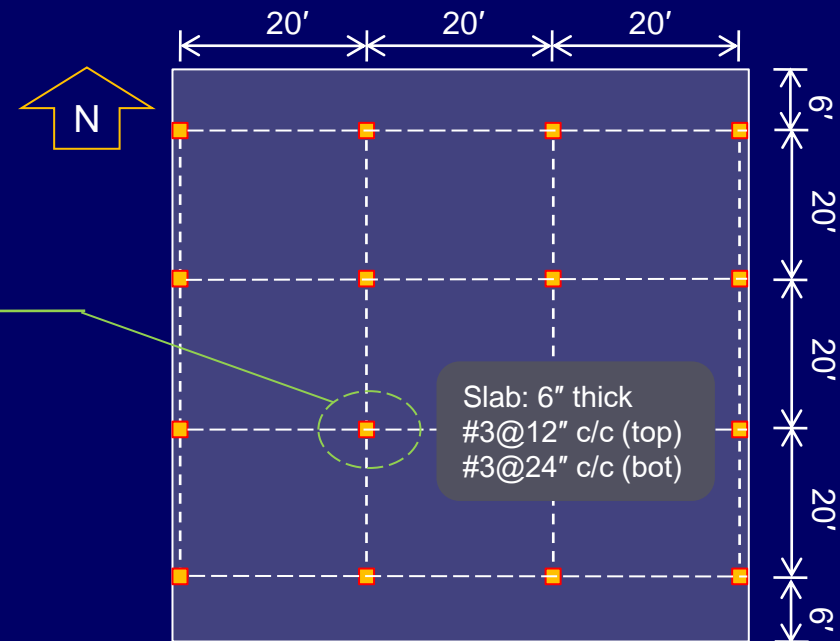
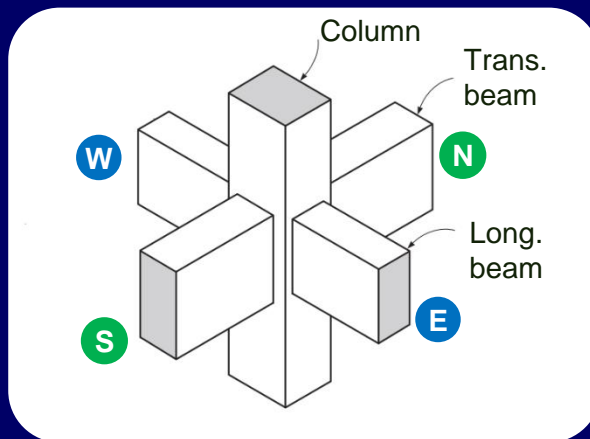





## Example 10.1

### □ Solution

#### ➤ Step 1: Column Longitudinal Reinforcement Arrangement Check

- The provided 8-#11 bars in column do not ensure a uniform distribution. To rectify this, change the arrangement to 12-#9 bars as shown below.

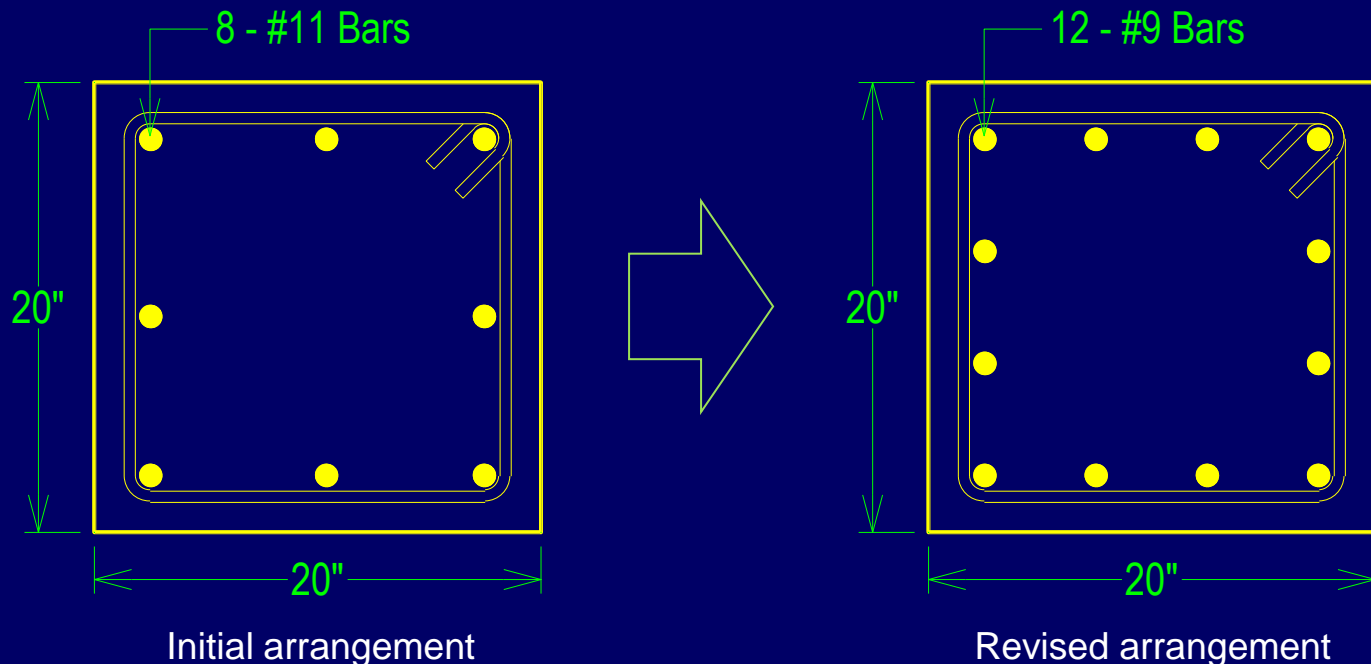



## Example 10.1

### □ Solution

#### ➤ Step 2: Check for Joint Dimensions for Slippage

- Dimension of column parallel to beam's longitudinal reinforcement needs to be at least:

$$h_{col} = \frac{20f_y}{60000} d_{b,beam} = \frac{20 \times 60000}{60000} \times 1 = 20'' \rightarrow OK$$

- Dimension of beam parallel to column's longitudinal reinforcement needs to be at least:

$$h_{beam} = \frac{20f_y}{60000} d_{b,col} = \frac{20 \times 60000}{60000} \times 1.128 = 22.6'' > 22''$$

Therefore, to comply with this requirement, 24 inches deep beams will be considered.



## Example 10.1

### □ Solution

#### ➤ Step 3: Determination of Horizontal Transverse Reinforcement

The transverse reinforcement shall be at least:

$$A_{sh} = \text{larger} \left[ 0.3 \frac{s_h b_c'' f_c'}{f_{yt}} \left( \frac{A_g}{A_{ch}} - 1 \right), 0.09 \frac{s_h b_c'' f_c'}{f_{yt}} \right]$$

Substituting values, we get

$$A_{sh} = \text{larger} \left[ 0.3 \frac{17 \times 10}{60} \left( \frac{20^2}{17^2} - 1 \right), 0.09 \frac{17 \times 10}{60} \right] s_h$$

$$A_{sh} = \text{larger} [0.326, 0.255] s_h = 0.326 s_h$$

This value can be reduced to half if  $b_w \geq 0.75 h_c$

$$0.75 h_c = 0.75 \times 20 = 15''$$

$$\text{Since } b_w = 16'' > 15'' \rightarrow A_{sh} = 0.326 s_h / 2 = 0.163 s_h$$

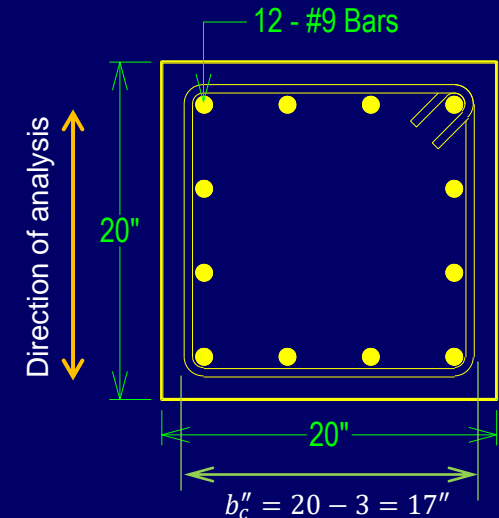



## Example 10.1

### □ Solution

#### ➤ Step 3: Determination of Horizontal Transverse Reinforcement

Using 4-legged #4 bars with  $A_{sh} = 4 \times 0.20 = 0.8 \text{ in}^2$ , the required spacing is:

$$s_h = \frac{0.80}{0.163} = 4.9'' \text{ c/c}$$

The spacing  $s_h$ , should not exceed  $s_{max}$ .

$$s_{max} = \begin{cases} h_c/4 = 20/4 = 5'' \\ 6d_{b,col} = 6 \times 1.128 = 6.8'' \\ 6'' \end{cases}$$

Provided spacing is OK.

Finally provide 4-legged #4@4'' c/c.

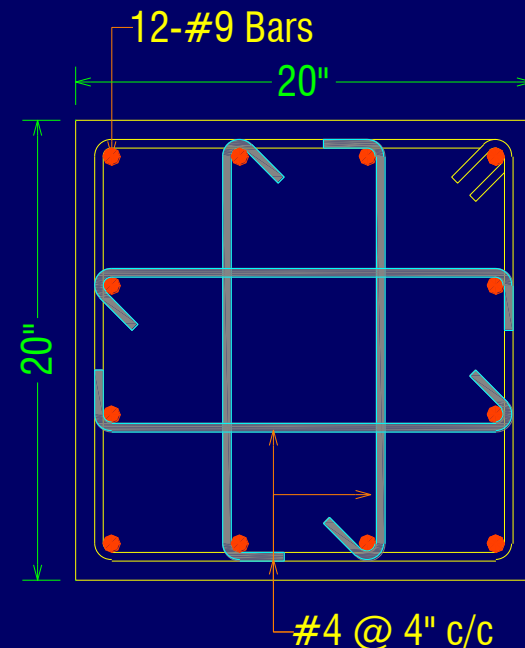



## Example 10.1

### □ Solution

#### ➤ Step 4: Computation of Joint Shear Demand

The total horizontal shear demand  $V_u$  is given by

$$V_u = T_{b1} + T_{b2} + T_{s1} + T_{s2} - V_{col} \quad \text{----- eq (i)}$$

$T_{b1}$ ,  $T_{s1}$  and  $T_{s2}$  are calculated as;

$$T_{b1} = 1.25A_s f_y = 1.25(5 \times 0.79) \times 60 = 296.25 \text{ kip}$$

$$T_{b2} = 1.25A_s f_y = 1.25(3 \times 0.79) \times 60 = 177.75 \text{ kip}$$

$$T_{s1} = 1.25A_{s(-)} f_y = 1.25(4 \times 0.11) \times 60 = 33 \text{ kip}$$

$$T_{s2} = 1.25A_{s(+)} f_y = 1.25(2 \times 0.11) \times 60 = 16.5 \text{ kip}$$

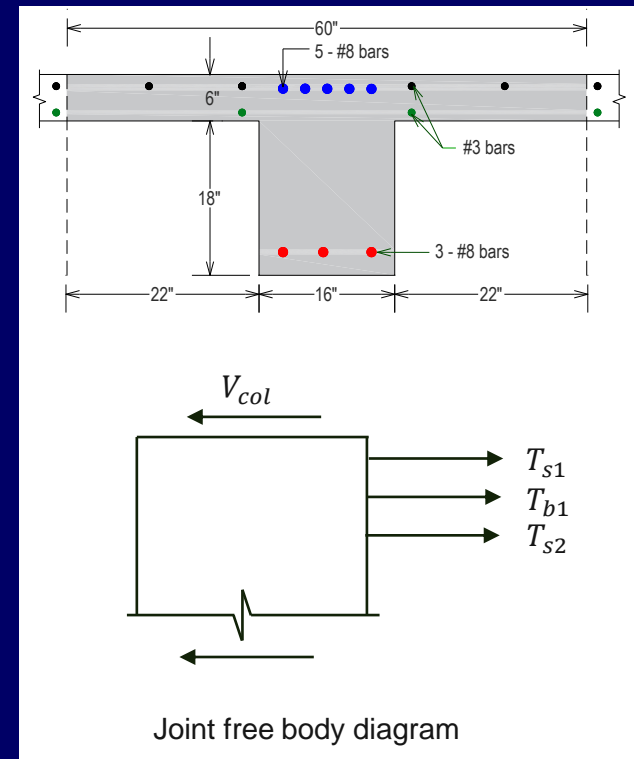



## Example 10.1

### □ Solution

#### ➤ Step 4: Computation of Joint Shear Demand

The column force  $V_{col}$  can be determined as;

$$V_{col} = \frac{M_{pr1} + M_{pr2}}{l_c}$$

$$M_{pr1} = T_{b2} \left( d - \frac{a}{2} \right) = T_{b2} \left( d - \frac{T_{b2}}{2(0.85 \times f'_c b_e)} \right)$$

Substituting the values, we get

$$M_{pr1} = 177.75 \times \left( 24 - 3.7^* - \frac{177.75}{2(0.85 \times 10 \times 60)} \right)$$

$$M_{pr1} = 3577.35 \text{ in. kip}$$

- In locations where there is interference between bars from the normal and spandrel beams, assume ,  $d = h - 3.7''$  for the spandrel beam.
- For other cases,  $d = h - 2.7''$ .

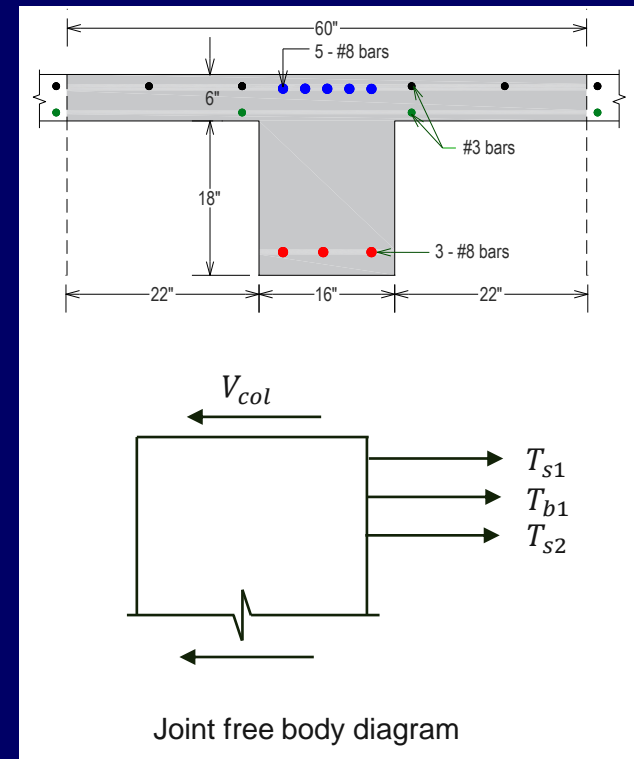



## Example 10.1

### □ Solution

#### ➤ Step 4: Computation of Joint Shear Demand

$$M_{pr2} = (T_{b1} + T_{s1} + T_{s2}) \times \left(d - \frac{a}{2}\right)$$

$$a = \frac{T_{b1} + T_{s1} + T_{s2}}{0.85f'_c b_w} = \frac{296.25 + 33 + 16.5}{0.85 \times 10 \times 16} = 2.54''$$

$$M_{pr2} = (296.25 + 33 + 16.5) \times \left(24 - 2.7 - \frac{2.54}{2}\right) = 6925.37 \text{ in. kip}$$

$$V_{col} = \frac{M_{pr1} + M_{pr2}}{l_c} = \frac{3577.34 + 6925.37}{12 \times 12} = 72.94 \text{ kip}$$

Substituting the values in eq(i), we get

$$V_u = T_{b1} + T_{b2} + T_{s1} + T_{s2} - V_{col}$$

$$V_u = 296.25 + 177.5 + 33 + 16.5 - 72.94 = 450.31 \text{ kip}$$



## Example 10.1

### □ Solution

#### ➤ Step 5: Computation of Joint Shear Capacity

The design shear capacity of joint  $V_n$  as per ACI 352 R Section 4.3.1 is given by

$$\phi V_n = \phi \gamma \sqrt{f'_c} b_j h_c$$

For the given case,  $\gamma = 20$  (from figure 4.5)

$$b_j = \min \left( b_c, \frac{b_b + b_c}{2}, b_b + \frac{\sum m h_c}{2} \right)$$

$$b_j = \min \left( 20, \frac{16 + 20}{2}, 16 + 2(2) \right) = 18''$$

$$\phi V_n = 0.75 \times 20 \times \sqrt{10000} \times 18 \times 20 / 1000 = 540 \text{ kip}$$

Hence

$$\phi V_n = 540 \text{ kip} > V_u = 450.31 \text{ kip} \rightarrow OK$$

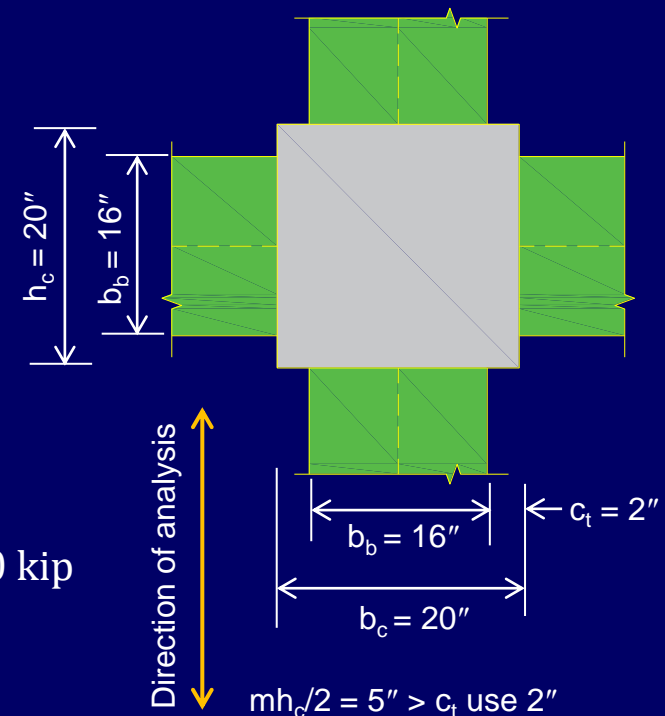





## Example 10.1

### □ Solution

#### ➤ Step 6: Calculation of Flexural Strength Ratio

From interaction curve of column, for a given axial demand of 400 kip, the nominal moment capacity of column is  $M_{nc} = 720.89$  ft-kip or 8650.68 in.kip

The beam flexural strengths have been found earlier using  $\alpha = 1.25$

$$M_{n1} = \frac{M_{pr1}}{1.25} = \frac{3577.35}{1.25} = 2861.88 \text{ in. kip}$$

$$M_{n2} = \frac{M_{pr2}}{1.25} = \frac{6925.37}{1.25} = 5540.30 \text{ in. kip}$$

$$\frac{\sum M_{nc}}{\sum M_{nb}} = \frac{2 \times 8650.68}{2861.88 + 5540.30} = 2.1$$

Since the ratio is greater than 1.2, the flexural strength of column is adequate.

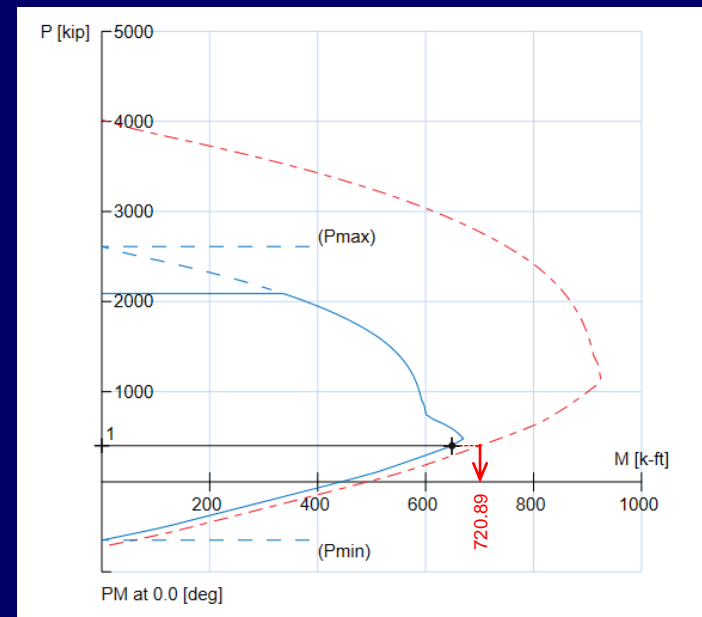



## Example 10.2

### □ Problem Statement

**Design** the Exterior Type 2 connection shown below as per ACI 352.

- Column: 24"x28" with 14-#9 bars, subjected to  $P_u = 540$  kips
- Transverse beam (N-S): 26"x28" with 8 - #9 bars (top) and 6 - #8 (bot)
- Longitudinal beam (E-W): 22"x28" with 6 - #10 bars (top) and 4 - #9 (bot)
- Story height: 12 ft.
- $f'_c = 8$  ksi and  $f_y = 60$  ksi

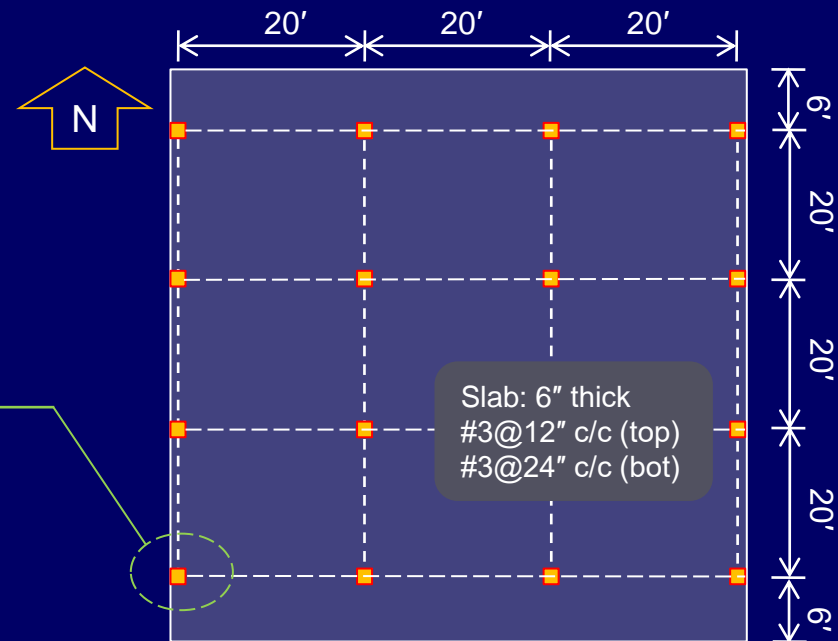
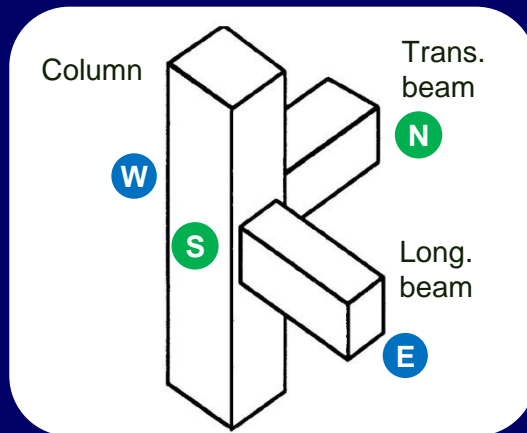



## Example 10.2

### □ Solution

#### ➤ Step 1: Column Longitudinal Reinforcement Arrangement Check

The provided 14-#9 bars in column are evenly distributed and hence the arrangement is acceptable.

#### ➤ Step 2: Check for Joint Dimensions for Slippage

As it is a corner joint, therefore the  $20d_b$  check for column dimension parallel to beam longitudinal reinforcement need not to be checked. The column dimension shall be at least:

$$h_{col} = \frac{20f_y}{60000} d_{b,beam} = \frac{20 \times 60000}{60000} \times 1.128 = 22.6''$$

Provided depth of 24" is satisfactory.



## Example 10.2

### □ Solution

#### ➤ Step 3: Determination of Horizontal Transverse Reinforcement

The transverse reinforcement shall be at least:

$$A_{sh} = \text{larger} \left[ 0.3 \frac{s_h b_c'' f_c'}{f_{yt}} \left( \frac{A_g}{A_{ch}} - 1 \right), 0.09 \frac{s_h b_c'' f_c'}{f_{yt}} \right]$$

Where;

$$A_g = 24 \times 28 = 672 \text{ in}^2$$

$$A_{ch} = 21 \times 25 = 525 \text{ in}^2$$

$$f_c' = 8 \text{ ksi} \quad \text{and} \quad f_y = 60 \text{ ksi}$$

$$b_c'' = 25'' \quad (\text{for analysis in N-S direction})$$

$$b_c'' = 21'' \quad (\text{for analysis in E-W direction})$$

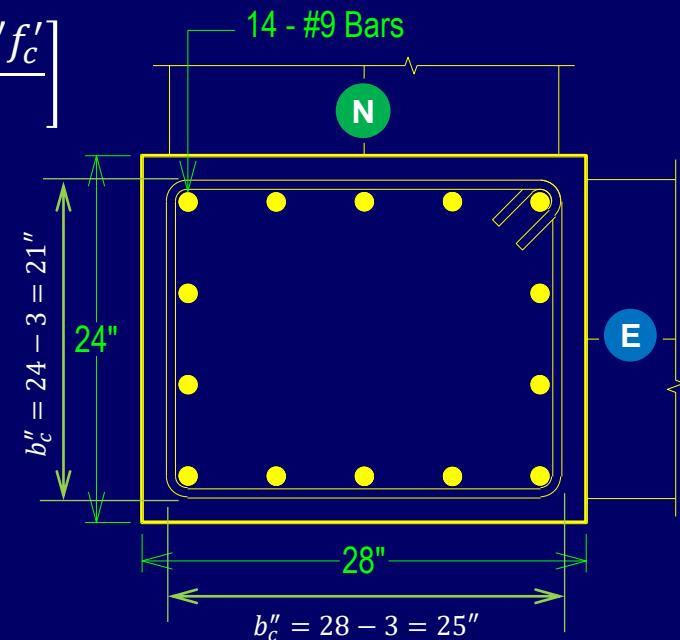



## Example 10.2

### □ Solution

#### ➤ Step 3: Determination of Horizontal Transverse Reinforcement

Parameters	Direction of Analysis	
	E-W	N-S
$A_{sh}$ (in <sup>2</sup> )	$0.252s_h$	$0.300s_h$
$s_{max}$ (in.)	6"	6"
$s_h$ selected (in.)	4"	4"
No. of legs	4	4
Detailing	#5 hoop + 2 - #5 ties	#5 hoop + 2 - #5 ties

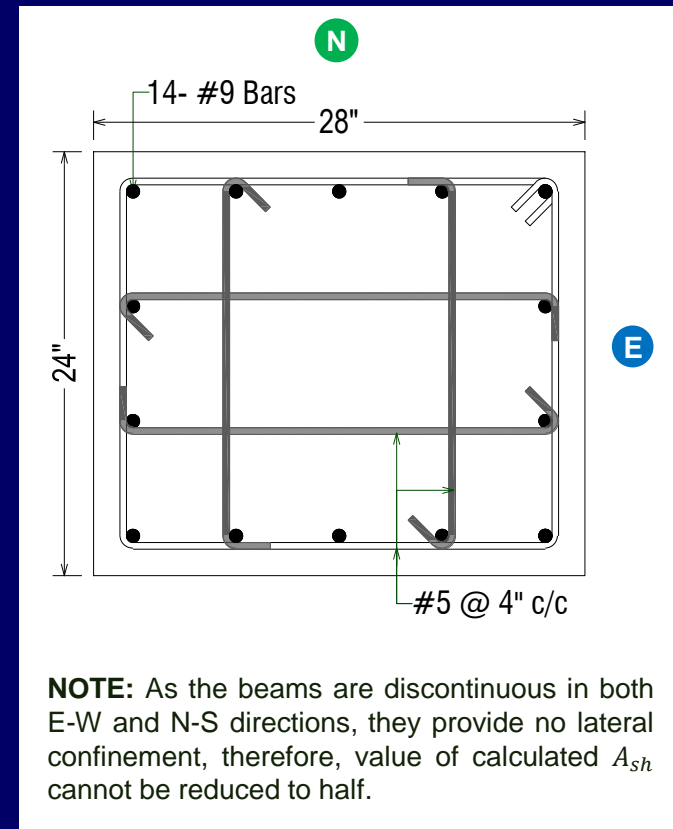



## Example 10.2

### □ Solution

#### ➤ Step 4: Computation of Joint Shear Demand

The total horizontal shear demand  $V_u$  is given by

$$V_u = T_{b1} + T_{b2} + T_{s1} + T_{s2} - V_{col} \quad \text{----- eq (i)}$$

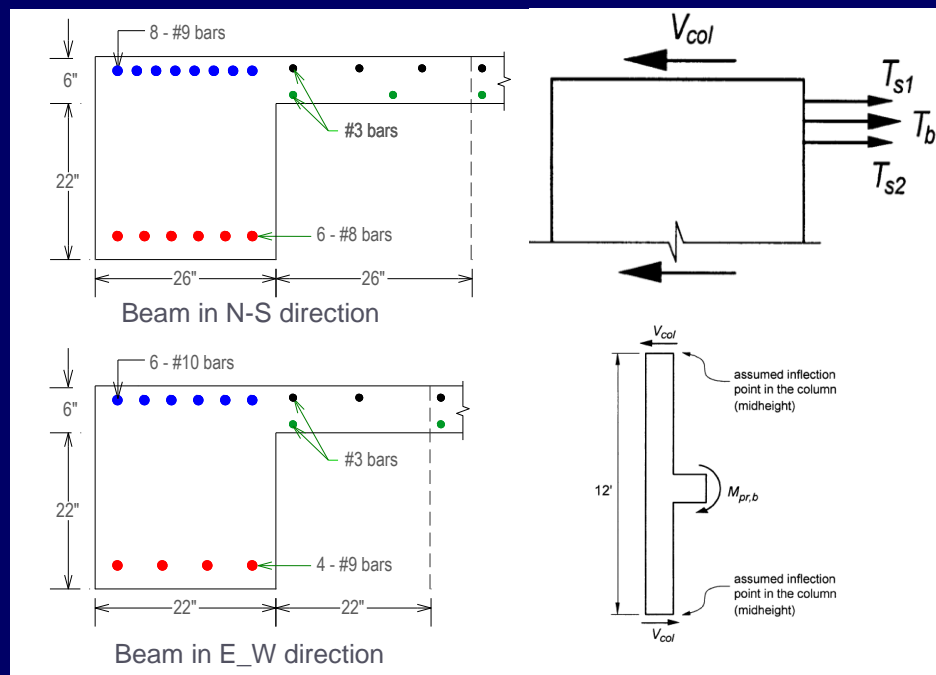



## Example 10.2

### □ Solution

#### ➤ Step 4: Computation of Joint Shear Demand

The total horizontal shear demand  $V_u$  in each direction is calculated as follows:

Parameters	N-S direction	E-W direction
$T_{b1}$	$(8 \times 1.00) \times 1.25 \times 60 = 600 \text{ kip}$	$(6 \times 1.27) \times 1.25 \times 60 = 571.5 \text{ kip}$
$T_{s1}$	$(3 \times 0.11) \times 1.25 \times 60 = 24.75 \text{ kip}$	$(2 \times 0.11) \times 1.25 \times 60 = 16.5 \text{ kip}$
$T_{s2}$	$(2 \times 0.11) \times 1.25 \times 60 = 16.5 \text{ kip}$	$(1 \times 0.11) \times 1.25 \times 60 = 8.25 \text{ kip}$
$a$	$(T_{b1} + T_{s1} + T_{s2})/0.85f'_c b = 3.63'' \text{ in.}$	$(T_{b1} + T_{s1} + T_{s2})/0.85f'_c b = 3.98'' \text{ in.}$
$M_{pr}$	$(T_{b1} + T_{s1} + T_{s2})(d - a/2) = 15059.76 \text{ in.kip}$ (assume $d = h - 2.7$ )	$(T_{b1} + T_{s1} + T_{s2})(d - a/2) = 13302.34 \text{ in.kip}$ (assuming $d = h - 3.7$ )
$V_{col}$	$M_{pr}/l_c = 104.58 \text{ kip}$	$M_{pr}/l_c = 92.38 \text{ kip}$
$V_u$	$T_{b1} + T_{s1} + T_{s2} - V_{col} = \mathbf{536.67 \text{ kips}}$	$T_{b1} + T_{s1} + T_{s2} - V_{col} = \mathbf{503.87 \text{ kips}}$



## Example 10.2

### □ Solution

#### ➤ Step 5: Computation of Joint Shear Capacity

The design shear capacity of joint  $V_n$  as per ACI 352 R Section 4.3.1 is given by

$$\phi V_n = \phi \gamma \sqrt{f'_c} b_j h_c$$

For the given case,  $\gamma = 12$  (from figure 4.5)

$$b_j = \min \left( b_c, \frac{b_b + b_c}{2}, b_b + \frac{\sum m h_c}{2} \right)$$

$\phi V_n$  in each direction is calculated as under:

Direction	$b_b$ (in.)	$b_c$ (in.)	$h_c$ (in.)	$b_j$ (in.)	$\phi V_n$ (kip)	$V_u$ (kip)	Remarks
N-S	26	28	24	27	522	536.67	Almost OK
E-W	22	24	28	23	518	503.87	OK

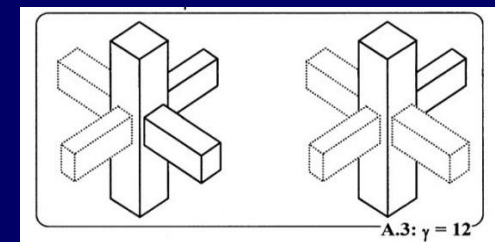
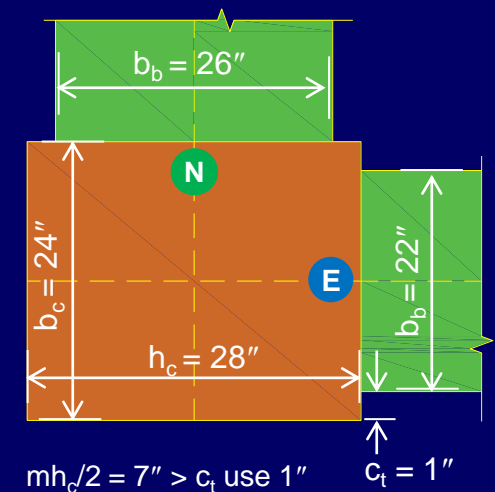





## Example 10.2

### □ Solution

#### ➤ Step 6: Calculation of Flexural Strength Ratio

From interaction curve of column, for a given axial demand of 400 kip, we have

$$M_{nc(N-S)} = 1086 \text{ ft.kip or } 13032 \text{ in.kip} \quad \text{and} \quad M_{nc(E-W)} = 1262 \text{ ft.kip or } 15144 \text{ in.kip}$$

$$M_{nb(N-S)} = 12047.2 \text{ in.kip}$$

$$M_{nb(E-w)} = 10725.6 \text{ in.kip}$$

Now, for N-S direction;

$$\frac{\sum M_{nc}}{\sum M_{nb}} = \frac{2 \times 13032}{12047.81} = 2.2 > 1.2 \rightarrow OK$$

Similarly for E-W direction:

$$\frac{\sum M_{nc}}{\sum M_{nb}} = \frac{2 \times 15144}{10641.87} = 2.8 > 1.2 \rightarrow OK$$

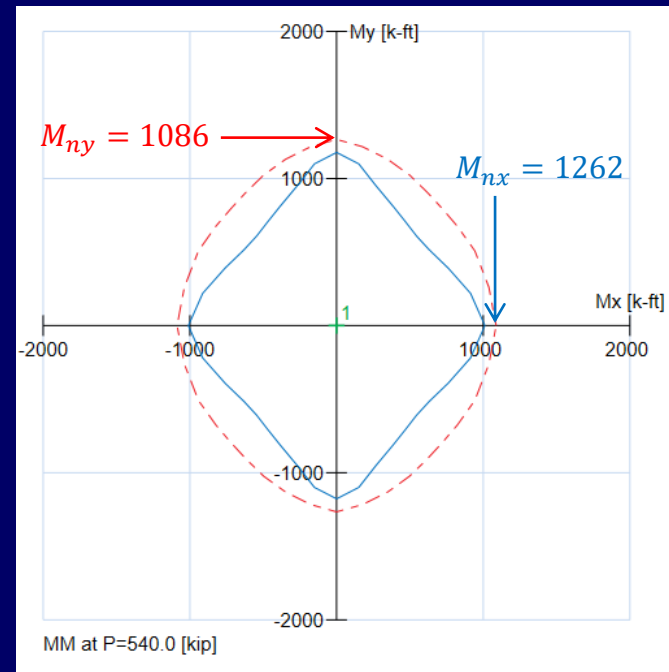



## Example 10.2

### □ Solution

#### ➤ Step 7: Check for Anchorage of Beam Reinforcement

The development length with hook is given by

$$l_{dh} = \frac{\alpha f_y d_b}{75 \sqrt{f'_c}}$$

For N-S direction:

$$l_{dh} = \frac{1.25 \times 60 \times (1.128)}{75 \sqrt{8000}} = 12.6''$$

Available length in N-S direction is  $24 - 2(1.5) - 0.625 = 20.375 \text{ in} > 12.6'' \rightarrow \text{OK}$

For E-W direction:

$$l_{dh} = \frac{1.25 \times 60 \times (1.270)}{75 \sqrt{8000}} = 14.2''$$

Available length in E-W direction is  $28 - 2(1.5) - 0.625 = 24.375 \text{ in} > 14.2'' \rightarrow \text{OK}$

→ Diameter of #5 stirrup



# References

- Recommendations for Design of Beam-Column Connections in Monolithic Reinforced Concrete Structures (ACI 352R-02)
- Reinforced Concrete - Mechanics and Design (7<sup>th</sup> Ed.) by James MacGregor.
- Design of Concrete Structures 14th / 15th edition by Nilson, Darwin and Dolan.
- Building Code Requirements for Structural Concrete (ACI 318-19)
- Building Code Requirements for Structural Concrete (ACI 318-02)



# Appendix

## ACI 318 APPENDIX B—STEEL REINFORCEMENT INFORMATION

### ASTM STANDARD REINFORCING BARS

Bar size, no.	Nominal diameter, in.	Nominal area, in. <sup>2</sup>	Nominal weight, lb/ft
3	0.375	0.11	0.376
4	0.500	0.20	0.668
5	0.625	0.31	1.043
6	0.750	0.44	1.502
7	0.875	0.60	2.044
8	1.000	0.79	2.670
9	1.128	1.00	3.400
10	1.270	1.27	4.303
11	1.410	1.56	5.313
14	1.693	2.25	7.65
18	2.257	4.00	13.60